

CATALOGO PARTI DI RICAMBIO
 CATALOGUE OF SPARE PARTS
 CATALOGUE PIECES DE RECHANGE
 ERSATZTEILKATALOG
 CATALOGO DE PIEZAS DE REPUESTO



CODICE MOTOCICLO	38-67540-0-97	250cc
MOTORCYCLE COD.	38-67550-0-97	400cc
REF. CICLO A VITESSE	38-67560-0-97	450cc
FAHRENG CODE	38-67570-0-97	525cc
CODIGO MOTOCICLO		

DAL N. TELAIO	ZD3E1000050000154
FROM FRAME N.	ZD3E1010050000303
DE NUMERO CADRE	ZD3E1020050000611
AB FAHRGESTELNUMMER	ZD3E1030050000278
DESDE NUMERO CHASSIS	

Forcella
Front fork
Fourche avant
Gabel
Horquilla

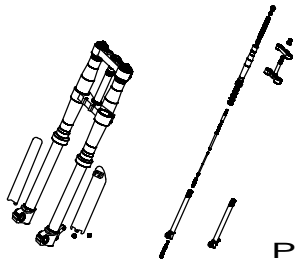

PAG. 3

Manubrio
Handlebar
Guidon
Manillar
Manillar

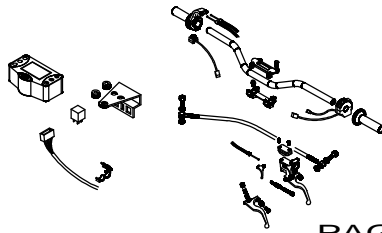

PAG. 4

Telaio
Frame
Cadre
Fahrgestell
Chassis

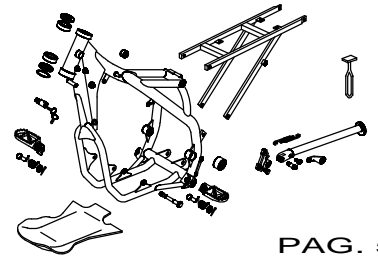

PAG. 5

Forcellone
Swinging arm
Bras oscillant
Schwingarm
Basculante

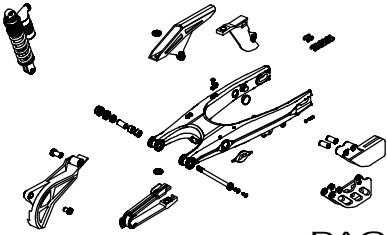

PAG. 6

Silenziatore e Marmitta
Silencer and muffler
Silencieux et pot d'echapp.
Auspuff
Silenciador

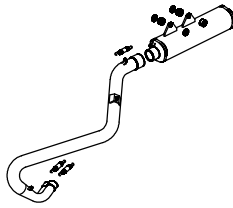

PAG. 7

Filtro e scatola aspirazione
Filter and injection box
Filtre et
Luftfilter und filterkasten
Filtro y escatula aspiracion

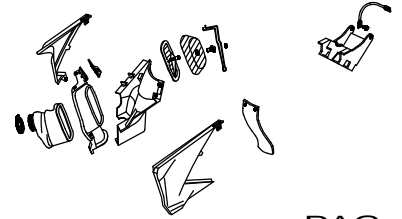

PAG. 8

Ruota anteriore
Front wheel
Roue avant
Vorderrad
Rueda delantera

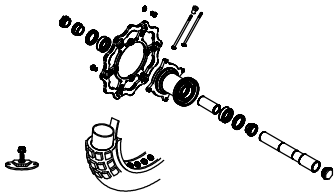

PAG. 9

Ruota posteriore
Rear wheel
Roue arriere
Hinterrad
Rueda trasera

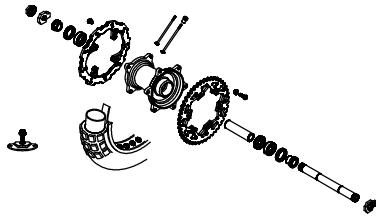

PAG. 10

Freni
Brakes
Freins
Bremsen
Frenos

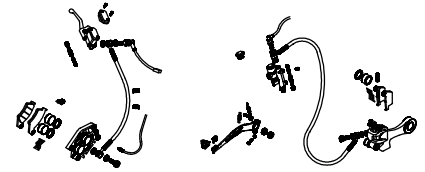

PAG. 11

Parafanghi
Fenders
Garde-boues
Kotflügel
Guardabarras

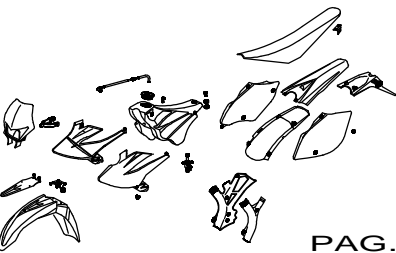

PAG. 12

Bilanciere
Bumper rod
Balancier
Schwinghebel
Balance

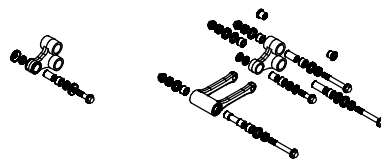

PAG. 13

Impianto elettrico
Electrical systeme
Installation électrique
Elektrische anlage
Instalacion electrica

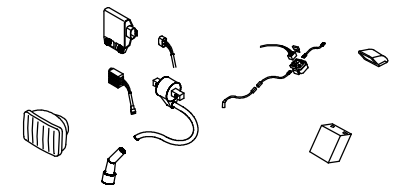

PAG. 14

Radiatore
Radiator
Radiador
Kühler
Radiador

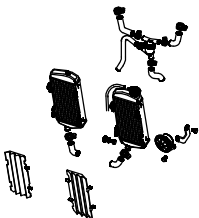

PAG. 15

Particolari non figuranti
Not mentioned particulars
Particuliers pas mentionnes
Nicht verzeichnete teile
Particulares no figurados

PARTICOLARI NON FIGURANTI
SUPPLEMENTARY PARTS LIST
PARTICULIERS PAS MENTIONNES
NICHT VERZEICHNETE TEILE
PARTICULARES NO FIGURADOS

PAG. 16

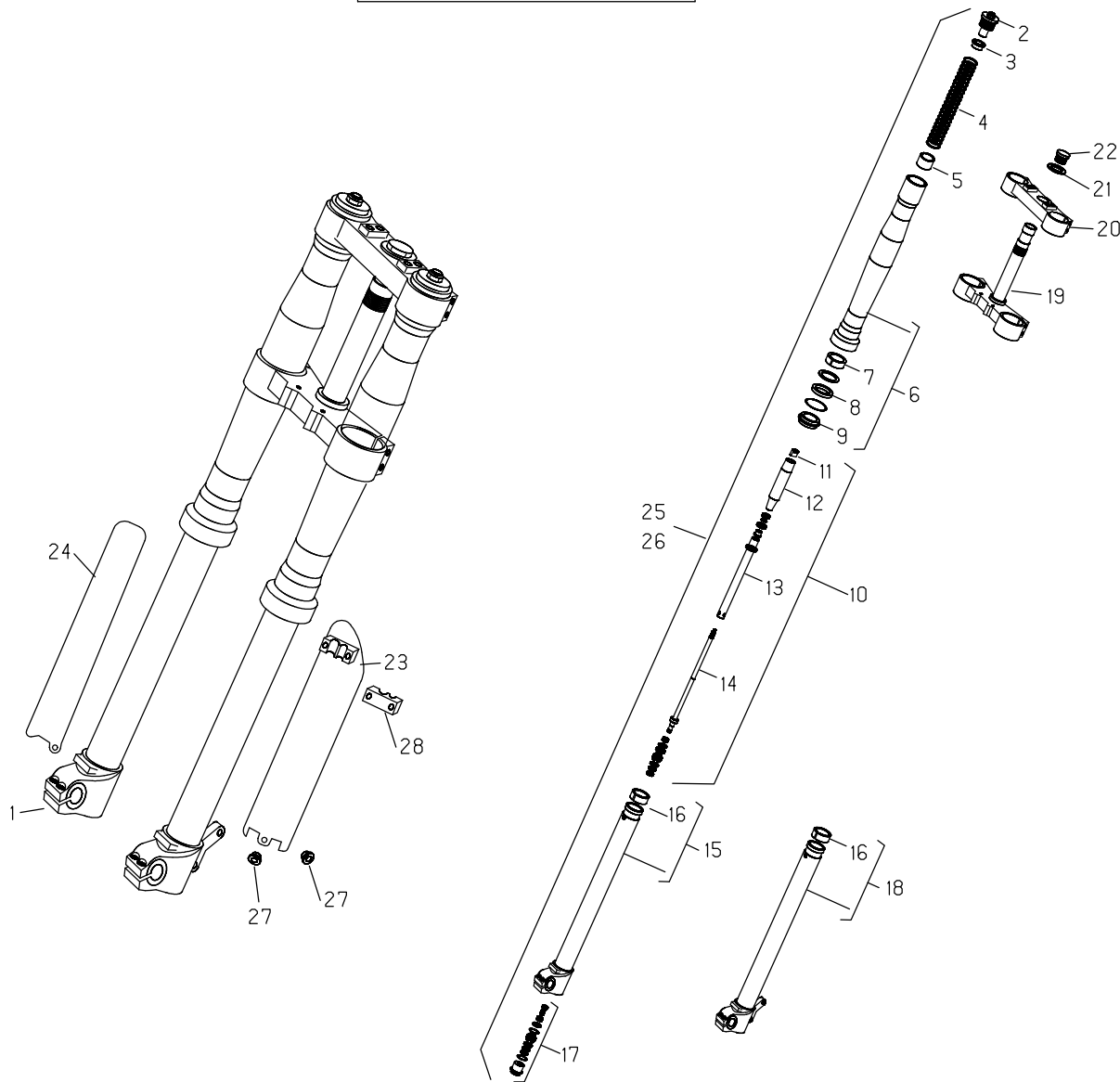

Pos	Number	Descrizione	Description	Description	Beschreibung	Descripción
1	15-08051	Forcella RR-4T	Front fork RR-4T	Fourche	Gabel RR-4T	Horquilla compl.
2	29-01965	Tappo forcella	Fork cover	Bouchon fourche	Gabel Stopfen	Tapon horquilla
3	10-41476	Anello per molla forcella	Front fork spring ring	Joint ressort fourche	Gabelsfedering	Junta muelle horquilla
4	22-52709	Molla forcella	Fork spring	Ressort fourche	Gabel Feder	Muelle horquilla
5	29-40470	Tubo precarico molla forcella	Fork spring tube	Tube ressort fourche	Federschlauch Gabel	Tubo muelle horquilla
6	16-18655	Gamba forcella	F/fork leg	Jante fourche	Gabelbein	Bravo horquilla
7	11-31310	Boccola superiore forcella	F/fork up. Bush	Douille superieure fourche	Gabelsbuchse oben	Casquillo superior horquilla
8	10-41462	Anello di tenuta forcella	Fork oil seal	Bague d'etancheite fourche	Dichtring RSU-Gabel	Junta horquilla
9	10-41477	Anello raschiapolvere forcella	F/fork dust ring	Bague de fourche	Staubkappe	Junta horquilla
10	12-32974	Cartuccia meccanica forcella	Kit mechanic spares fork	Cartouche mecanique fourche	Gabeldaempfer	Cartucho mecanica horquilla
11	13-29530	Dado spec. Forcella	F/fork spec. Nut	Ecrou spec. Fourche	Gabel special Mutter	Tuerca esp. Horquilla
12	29-40463	Tubo guidamolla forcella	Fork spring tube	Tube ressort fourche	Federschlauch Gabel	Tubo muelle horquilla
13	12-32959	Cartuccia forcella (custodia)	Fork spares	Cartouche fourche	Gabeldaempfer	Cartucho horquilla
14	12-32973	Cartuccia forcella (asta)	Fork spares	Cartouche fourche	Gabeldaempfer	Cartucho horquilla
15	29-40423	Tubo dx completo forcella	RH compl. Fork tube	Tube compl. Droit fourche	Gabelstandrohr rechts	Tubo derecho compl. Horquilla
16	11-31311	Boccola interna forcella	F/fork int. Bush	Douille interieure fourche	Gabelsbuchse innen	Casquillo interior horquilla
17	31-02175	Valvola fondo gamba forcella	Fork leg valve	Valve jante fourche	Gabelsbeinsicherung	Valvula brazo horquilla
18	29-40424	Tubo sx completo forcella	LH compl. Fork tube	Tube compl. Gauche fourche	Gabelstandrohr links	Tubo izquierdo compl. Horquilla
19	12-09702	Crociera con cannotto	Lowe yoke	Croisiere a/tube fourche	Untere Gabelbrücke	Pletina con tubo
20	29-50152	Testata forcella	Fork head	Tete fourche	Obere gabelbrueke	Culata horquilla
21	27-79102	Rondella forcella	Fork washer	Rondelle fourche	Gabel Scheibe	Arandela horquilla
22	13-30965	Dado 20x1,5 per forcella	F/fork 20x1,5 nut	Ecrou 20x1,5 fourche	Gabel Mutter 20x1,5	Tuerca horquilla 20x1,5
23	25-98895-1-59	Protezione tubo forcella sx	LH fork tube protection	Protection tube fourche gauche	Abdeckung Gabelschlauch li.	Proteccion tubo horquilla izquierdo
24	25-98894-1-59	Protezione tubo forcella dx	RH fork tube protection	Protection tube fourche droit	Abdeckung Gabelschlauch re.	Proteccion tubo horquilla derecho
25	16-00978	Gamba forcella sx completa	Complete left fork leg	Jante gauche compl. fourche	Gabelbein li.	Bravo horquilla izquierdo compl.
26	16-00979	Gamba forcella dx completa	Complete right fork leg	Jante droit compl. Fourche	Standrohr re	Bravo horquilla derecho compl.
27	13-54820	Distanziale 6,5/9/13,5x4,8	Spacer	Entretoise	Distanz	Distanciadore
28	25-91330-1-59	Ponticello tubo freno	Brake pipe sprocket	Etrier tube frein	Bügel Bremsschlauch	Abrazadera tubo freno

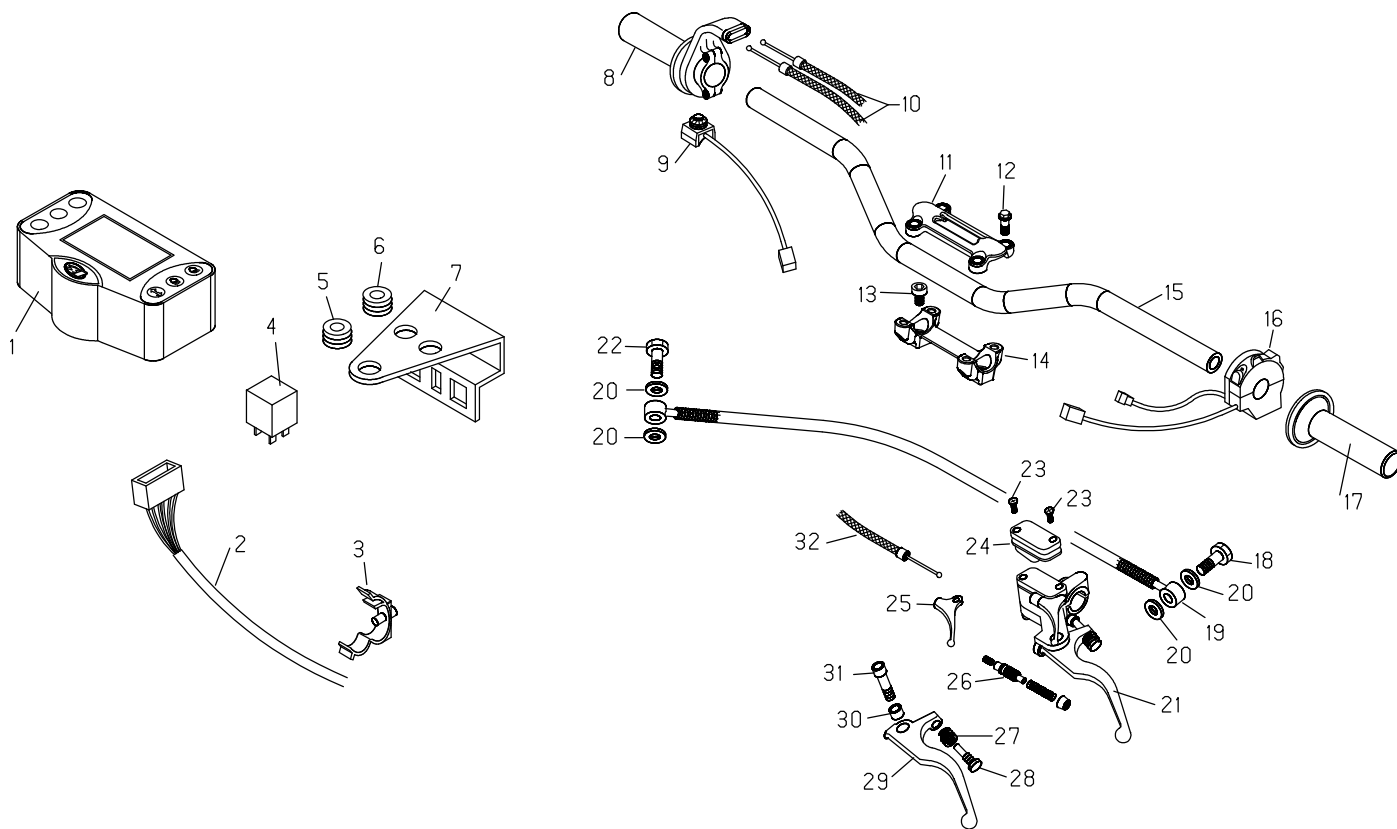

Pos	Number	Descrizione	Description	Description	Beschreibung	Descripción
1	12-09367	Conta-km	Speedometer	Compteur	Tachometer	Cuenta km. tr.
2	18-01589	Impianto centrale	Electric equipment	Installation centrale	Zentraler Kabelbaum	Instalacion central
3	25-24444	Passacavo a scatto d.19	Fair lead d.19	Passe-fils d.19	Kabelführung fahrgest	Pasa-cable d. 19
4	18-84946	Intermittenza	Flasher	Intermittence	Intermittenz	Intermitencia
5	16-34905	Gommino staffa conta-km	Bracket rubber	Caoutchouc etrier compteur	Gummi Tachometersbügel	Goma abrazadera cuentakilometr
6	16-34905	Gommino staffa conta-km	Bracket rubber	Caoutchouc etrier compteur	Gummi Tachometersbügel	Goma abrazadera cuentakilometr
7	28-98068	Supporto strumenti	Instruments support	Support instruments	Halter Werkzeuge	Soporte instrumentos
8	12-55097	Comando gas	Twist grip	Commande gaz	Gasgriff	Mando gas
9	18-84981	Interruttore avviamento	Start switch	Interruptor demarrage	Starterschalter	Interruptor arranque
10	29-15188	Trasmissione gas	Throttle cable	Cable gas	Gaszug	Cable transmision gas
11	12-08253	Cavallotto superiore forcella	Upper handlebar bracket	Crampillon superieur fourche	Lenkerböcke Gabel oben	Abrazadera superior horquilla
12	31-64070	Vite flangiata 8x25 ch10	Screw 8x25	Vis avec bride 8x25 ch10	Schraube 8x25	Tornillo especial 8.30
13	31-65626	Vite brugola 10x25 t.b.	Screw 10x25	Vis 10x25	Schraube 10x25	Tornillo 10x25
14	12-08254	Cavallotto inferiore forcella	Lower handlebar bracket	Crampillon inferieur fourche	Lenkerböcke Gabel unten	Abrazadera inferior horquilla
15	22-20388	Manubrio	Handlebar	Guidon	Lenker	Manillar
16	13-06506-8	Dip luci e frecce	Device	Dispositif feux et indicateurs	Licht- und Blinkerschalter	Dispositivo luces y flechas
17	22-18537	Manopole (coppia)	Grips (pair)	Poignees (couple)	Lenker Griffe	Puños goma (juego)
18	11-65035	Bullone forato 10x1	Special bolt	Boulon 10x1 x tube frein	Hohlschraube F.Bremse	Tornillo esp. talad.10.1
19	29-09102	Tubo frizione Idraulica	Clutch hose	Tube embrayage	Kupplungsleitung	Tubo embrague hidraulico
20	16-50510	Guarnizione 10x15x1 in rame	Gasket 10x15x1 copper	Joint 10x15x1 cuivre	Dichtung 10x15x1 Kupfer	Junta 10.15.1 (cobre)
21	21-02427	Leva com. frizione	Clutch lever	Levier complet embrayage	Kupplungsarmatur	Bomba embrague
22	11-65035	Bullone forato 10x1	Special bolt	Boulon 10x1 x tube frein	Hohlschraube F.Bremse	Tornillo esp. talad.10.1
23	31-23401-0-52	Vite coperchio serbatoio olio	Screw	Vis couvercle reservoir huile	Schraube	Tornillo tapa deposito aceite
24	20-05076	Kit serbatoio olio pompa	Oil seal cover for pump	Jeu reservoir huile pompe	Reparatursatz Bremsarmatur vo	luogo deposito bomba aceite
25	21-70146	Levetta alzavalvola	Valve lever	Levier valve	Sicherungshebel	Palanca valvula
26	20-05084	Kit pistoncino pompa	Piston kit for pump	Kit petit piston pompe	Reparatursatz Brems/Kupplungs	stung piston bomba
27	22-38702	Molla registro leva freno ant.	Front brake lever adjust spring	Ressort enregistrement levier	Feder	Muelle regul. bomba freno
28	31-88602	Vite registro leva frizione	Clutch lever screw	Vis levier embrayage	Schraube	Tornillo palanca embrague
29	21-27085	Leva com.friz.nuda	Clutch lever only	Levier complet embrayage nue	Kupplungshebel	Maneta embrague
30	11-26466	Boccola x leva	Bush	Douille	Buchse	Casquillo
31	31-96819	Vite spec. per leva	Special screw	Vis	Schraube	Tornillo
32	29-13060	Trasmissione alzavalvola	Valve transmission	Transmission valve	Sicherungsantrieb	Transmision valvula

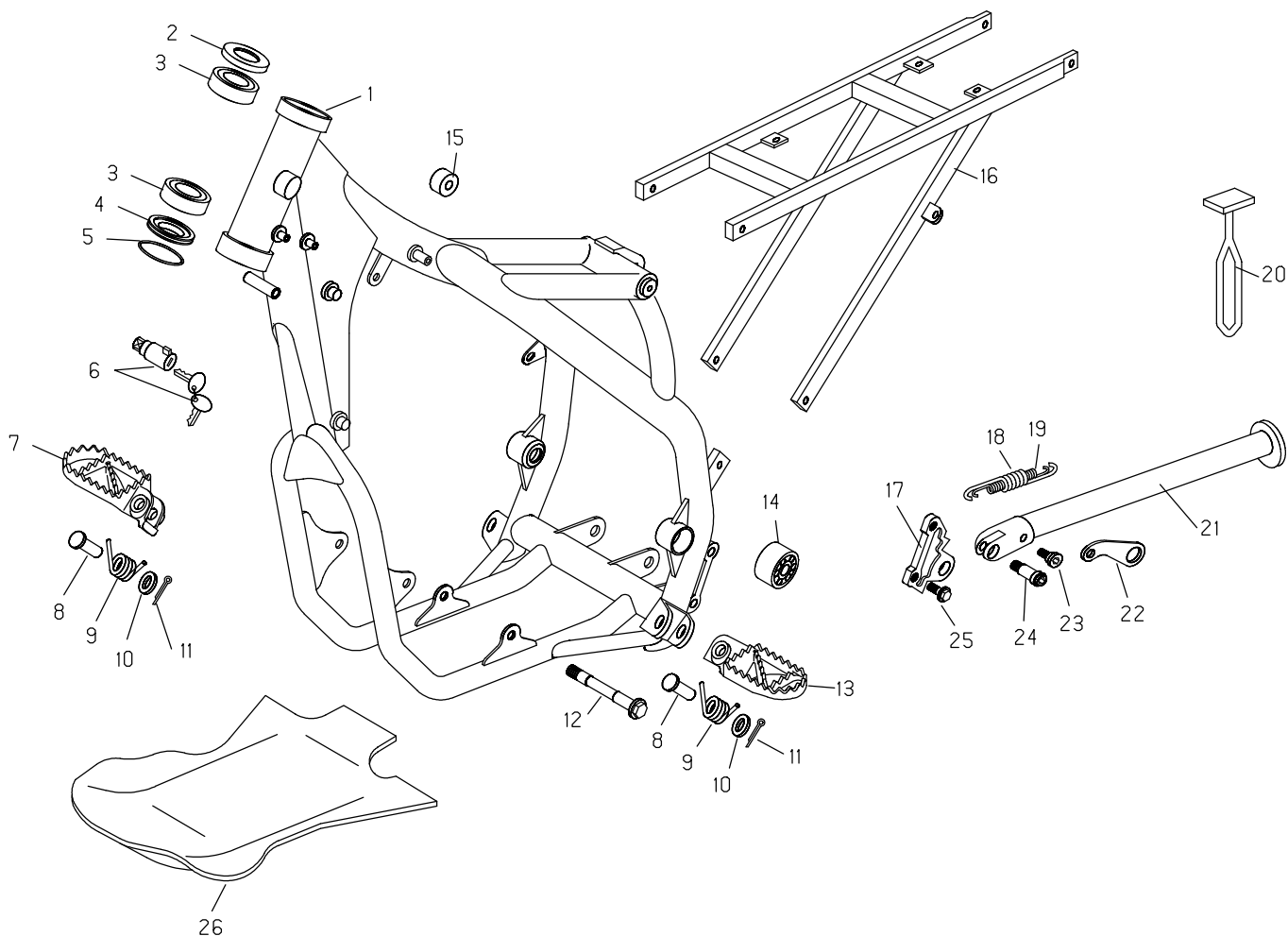

Pos	Number	Descrizione	Description	Description	Beschreibung	Descripción
1	29-11537-8-25	Telaio anteriore	Front frame	Cadre avant	Gutschrift Rahmen	Chasis
2	25-98782	Protezione cuscinetto sterzo	Ball-bearing protection	Protection roulement guidon	Abdeckung Lenkerslager	Protección cojinete manillar
3	12-99510	Cuscinetto conico 29x50x15	Conical bearing 29x50x15	Roulement conique 29x50x15	Lager 29x50x15	Cojinete conico 29.50.15
4	10-67535	Anello parapolvere forcella	F/fork ring	Cache poussiere fourche	F/Gabel Aluminium Ring	Junta guardapolvo dirección
5	10-66935	Anello OR	OR	OR	O-Ring	Junta torica
6	28-85861	Serratura bloccasterzo	Lock	Serrure blocage guidon	Lenkradschloss	Cerradura bloque manillar
7	25-32521	Pedana poggiapiedi dx	RH footrest	Repose-pieds droit	Fußraste re.	Estribera dhc
8	25-54465	Perno pedana	footrest pin	Pivot repose-pied	Rasten Pin	Eje estribera
9	22-62011	Molla pedana dx e sx	RH and LH footerest spring	Ressort repose-pied droit et gauche	Rasten/Feder re. und li.	Muelle derecha y izquierda estribera
10	27-54000	Rondella 10x21x2	Washer 10x21x2	Rondelle 10x21x2	Scheibe 10x21x2	Arandela 10x21x2
11	12-81993	Coppiglia 3x20	Split pin 3x20	Goupille 3x20	Splint 3x20	-
12	11-64607	Bullone spec. motore	Special bolt	Boulon spec.	Spezial Bolzen	Tornillo special
13	25-32531	Pedana poggiapiedi sx	LH footrest	Repose-pieds gauche	Fußraste li.	Estribera izq.
14	27-79431	Rotella guidacatena	Chaine roller	Galet guide de chaine	Rädchen Ketteführung	Arandela cadena
15	29-10310	Tampone serbatoio	Tank rubber pad	Tampon reservoir	Benzintank Schlegel	Tampon deposito
16	29-11433-8	Telaio posteriore	Rear frame	Cadre arriere	Rahmen hinten	Chasis posterior
17	28-97305	Staffa supporto cavalletto	Stand support bracket	Etrier support bequille	Klemme Seitenständer	Soporte cavalletto
18	22-48819	Molla cavalletto esterna	External stand spring	Ressort bequille exterieure	Seitenständer feder außen	Muelle caballete exterior
19	22-48818	Molla cavalletto interna	Inner stand spring	Ressort bequille interieure	Seitenständer feder innen	Muelle caballete interior
20	16-34907	Gommino ritenuta cavalletto	Stand rubber	Caoutchouc bequille	Gummi Seitenständer	Goma caballete
21	12-39896	Cavalletto	Stand	Bequille	Seitenständer	Caballete
22	25-57636	Piastrina per molla cavalletto	Stand spring plate	Plaquette ressort bequille	Halteplatte Seitenständersfeder	Placa muelle caballete
23	11-66612	Bullone spec. piastr. cavall.	Special bolt	Boulon spec.	Spezialschraube	Tornillo especial
24	11-66611	Bullone spec. cavalletto	Special bolt	Boulon spec.	Spezialschraube	Tornillo especial
25	11-54521	Bullone 8x16 rs c/rond. ch10	Bolt 8x16 ch10	Boulon 8x16 rs a/rondelle ch10	Schraube 8x16 ch 10	Tornillo 8.16 rs c/arandela
26	12-32207	Carter parasassi	Bumper	Bas moteur	Bodenplatte	Cubrecarter

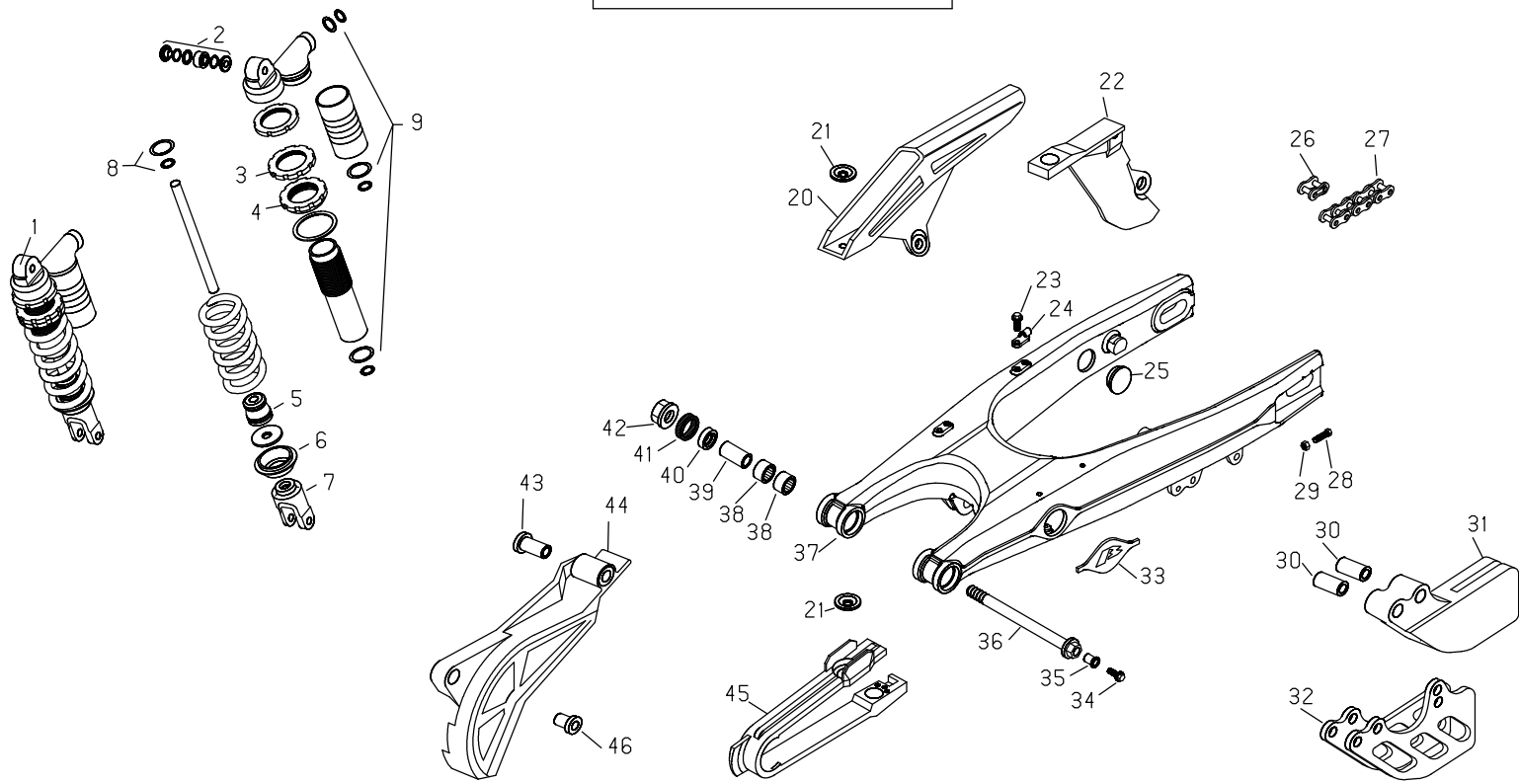

Pos	Number	Descrizione	Description	Description	Beschreibung	Descripción
1	10-03782	Ammortizzatore	Shock absorber	Ammortisseur	Stossdämpfer	Amortiguador
2	13-86078	Distanziali ammortizzatore	Spacer	Entretoise	Distanzscheibe	Distanciator
3	16-20821	Ghiera fissaggio ammortizz.	Shock absorber fixing ring nut	Bague fixation amortisseur	Befestigungsring stossdämpfer	Junta fijadora amortiguador
4	16-20280	Ghiera registro ammortizz.	Shock absorber adjusting ring nut	Bague réglage amortisseur	Regulierungsring stossdämpfer	Junta regularización amortiguador
5	29-10308	Tampone battuta ammortizz.	Shock absorber limit stop plug	Tampon fin course amortisseur	Stossdämpferanschlag	Tampón fin carrera amortiguador
6	15-39110	Fodero copristelo ammortizz.	Leg protection	Train flottage couvre-tige amm.	Federteller Stossdämpfer	Protector amortiguador
7	16-47820	Gruppo forchetta ammortizz.	Shock absorber inf. Connection	Exation inférieure amortisseur	Untere befestigung stossdämpfer	Fijador inferior amortiguador
8	20-11505	Kit gruppo guarniz.stelo amm.	Shock absorber slider gasket set	Joint tige amortisseur	Dichtungssatz hy. Einsatz stossdämpfer	Juego juntas cartucho amortiguador
9	20-11504	Kit gruppo guarniz. Ammort.	Shock absorber gasket set	Joints amortisseur	Dichtungssatz stossdämpfer	Juego juntas amortiguador
20	12-88591-1-36	Copricatena superiore	Up. Chain cover	Couvre-chaîne superieur	Kettenschutz oben	Cubrecadena superior
21	27-74786	Rondella bombata	Washer	Rondelle	Scheibe	Arandela
22	12-88592-1-36	Copricatena inferiore	Inf. Chain Cover	Couvre-chaîne infierieur	Kettenschutz unten	Cubrecadena inferior
23	11-46360	Bullone 5x16 ch 8 rs	Bolt 5x16	Boulon 5x16 ch 8 rs	Bolzen 5x16	Tornillo 5x16 llave 8 rs
24	15-14605	Fascetta tubo freno	Clamp	Collier tube frein disque	Schelle F. Bremsschlauch	Brida fijación tubo freno
25	29-10596-1-36	Tappo forcellone D:30	Swinging arm plug d.30	Bouchon bras oscillant d.30	Stopfen Schwinge D. 30	Tapon basculante d. 30
26	22-11223	Maglia congiunz. 5/8x1/4 (CZ)	Connecting link 5/8x1/4 (CZ)	Maillon jonction 5/8x1/4 (CZ)	Kettenschloss 5/8x1/4 (CZ)	Enganche cadena 5/8.1/4 (CZ)
	22-11224	Maglia congiunz. 5/8x1/4	Connecting link 5/8x1/4	Maillon jonction 5/8x1/4	Kettenschloss 5/8x1/4	Enganche cadena 5/8.1/4
27	12-08204	Catena 5/8x1/4 p.112	Chain 5/8x1/4 p.112	Chaîne 5/8x1/4 p.112	Kette 5/8x4 p.112	Cadena 5/8x1/4 p.112
	12-08206	Catena 5/8x1/4 p.114	Chain 5/8x1/4 p.114	Chaîne 5/8x1/4 p.114	Kette 5/8x4 p.114	Cadena 5/8x1/4 p.114
28	11-55909	Bullone 8x55 pf ch10	Bolt 8x55	Boulon 8x55 pf ch10	Bolzen 8x55	Tornillo 8.55 pf ch 10
29	13-17121	Dado spec. M8 flangiato ch10	Nut M8 special ch10	Ecrou M8 bride ch10	Mutter M8 SW 10	Tuerca M8 esp. Llave 10
30	13-49191	Distanziale	Spacer	Entretoise	Distanz	Distanciator
31	29-10069	Tassello guidacatena infer.	Lower sliding block	Cheville guide de chaîne inf.	Schwingschleifklotz unten	Protector cadena inferior
32	25-98922-8	Protezione tassello guidacat.	Sliding block cover	Protection goujon guide de chaîne	Abdeckung Ketteführungstück	Protección taco cadena
33	29-10597-1-36	Tappo forcellone D:35	Swinging arm plug d.35	Bouchon bras oscillant d.35	Stopfen Schwinge D. 35	Tapon basculante d.35
34	11-46401	Bullone 5x20 ch 8 rs	Bolt 5x20	Boulon 5x20 ch 8 rs	Bolzen 5x20	Tornillo 5x20 llave 8 rs
35	16-29620	Gommino fissaggio	Fixing grommet	Caoutchouc fixation	Befestigungsgummi	Goma fijación
36	25-47652	Perno forcellone	S/arm spindle	Pivot bras ascillant	Schwingenachse	Eje basculante
37	15-49637	Forcellone	Swinging arm	Bras oscillant	Schwinge	Basculante
38	11-22056	Boccola a rulli 22x 12 V	Needle bearing 22x 12 V	Douille a roulements 22x 12 V	Nadellager 22x12 V	Cojinete 22x12 V
39	13-49183	Distanziale forcellone	Spacer	Entretoise bras oscillant	DistanzSchwingenlagerung	Distanciator basculante
40	28-14081	Scodellino forcellone	Swinging arm lever	Cuvette bras oscillant	Schwinge Teller	Sopero basculante
41	10-64481	Anello paraolio 25x32x7	Oil seal 25x32x7	Joint spy 25x32x7	Wedi 25x32x7	Junta aceite 25x32x7
42	13-27121	Dado spec. forcellone	Swinging Arm special nut	Ecrou spec. Bras oscillant	Schwinge spezial Mutter	Tuerca esp. Basculante
43	13-49189	Distanziale	Spacer	Entretoise	Distanz	Distanciator
44	12-73077-1-36	Coperchio pignone catena	Sprocket cover	Couvercle pignon de chaîne	Deckel Ketteritzel	Tapa
45	29-10068	Tassello guidacatena super.	Upper sliding block	Cheville guide de chaîne sup.	Schwingschleifklotz oben	Protector cadena superior
46	13-49190	Distanziale	Spacer	Entretoise	Distanz	Distanciator

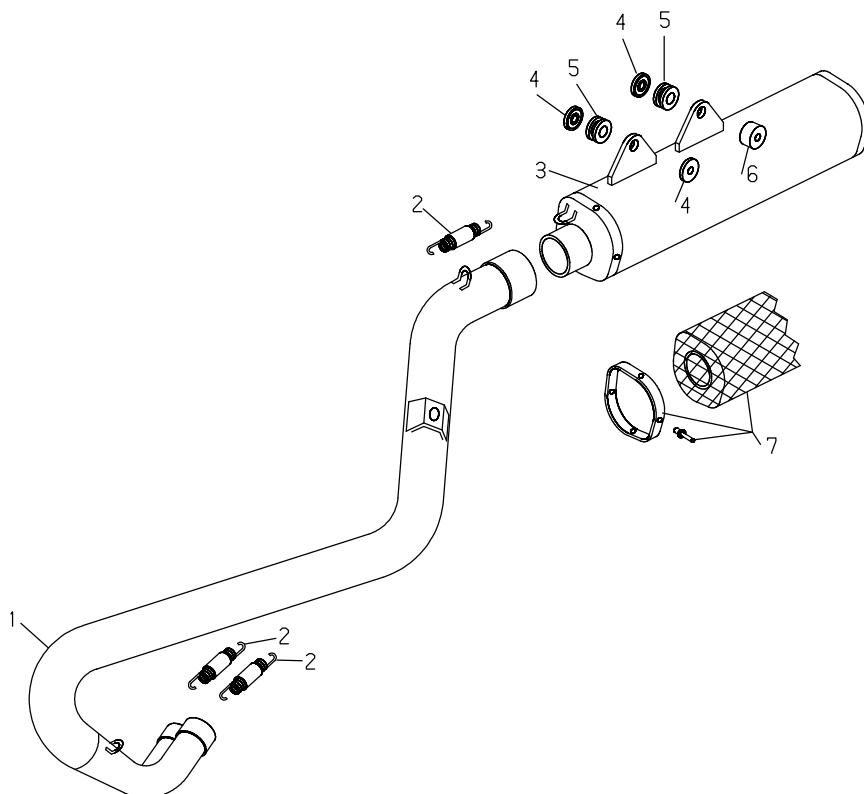

PER 250cc - FOR 250cc - POUR 250cc - FUER 250cc - POR 250cc

Pos	Number	Descrizione	Description	Description	Beschreibung	Descripción
1	29-16234	Tubo scarico	Exhaust tube	Tube vidange	Krümmer	Tubo escape parte
2	22-48814	Molla per tubo scarico	Exhaust pipe spring	Ressort tube d'echappement	Auspuff Feder	Muelle tubo escape
3	22-04164	Marmitta	Muffler	Pot d'echappement	Schalldämpfer	Escape
4	13-49187	Distanziale silent-block	Spacer	Entretoise	Distanz	Distanciador
5	28-91946	Silent-block marmitta	Silent-block	Silent-block pot d'echappement	Silent-Block	Silent-block escape
6	13-49188	Distanziale	Spacer	Entretoise	Distanz	Distanciador
7	20-12801	Kit fonassorbente x marmitta	Muffler sound absorbent set	kit insonore pour pot d'echappement	Schallschluckendes kit für schalldämpfer	Kit para insonorizacion x silenciado

PER - FOR - POUR - FUER - POR 400/450/525cc

Pos	Number	Descrizione	Description	Description	Beschreibung	Descripción
1	29-16233	Tubo scarico	Exhaust tube	Tube vidange	Krümmer	Tubo escape parte
2	22-48814	Molla per tubo scarico	Exhaust pipe spring	Ressort tube d'echappement	Auspuff Feder	Muelle tubo escape
3	22-04163	Marmitta	Muffler	Pot d'echappement	Schalldämpfer	Escape
4	13-49187	Distanziale silent-block	Spacer	Entretoise	Distanz	Distanciador
5	28-91946	Silent-block marmitta	Silent-block	Silent-block pot d'echappement	Silent-Block	Silent-block escape
6	13-49188	Distanziale	Spacer	Entretoise	Distanz	Distanciador
7	20-12801	Kit fonassorbente x marmitta	Muffler sound absorbent set	kit insonore pour pot d'echappement	Schallschluckendes kit für schalldämpfer	Kit para insonorizacion x silenciado

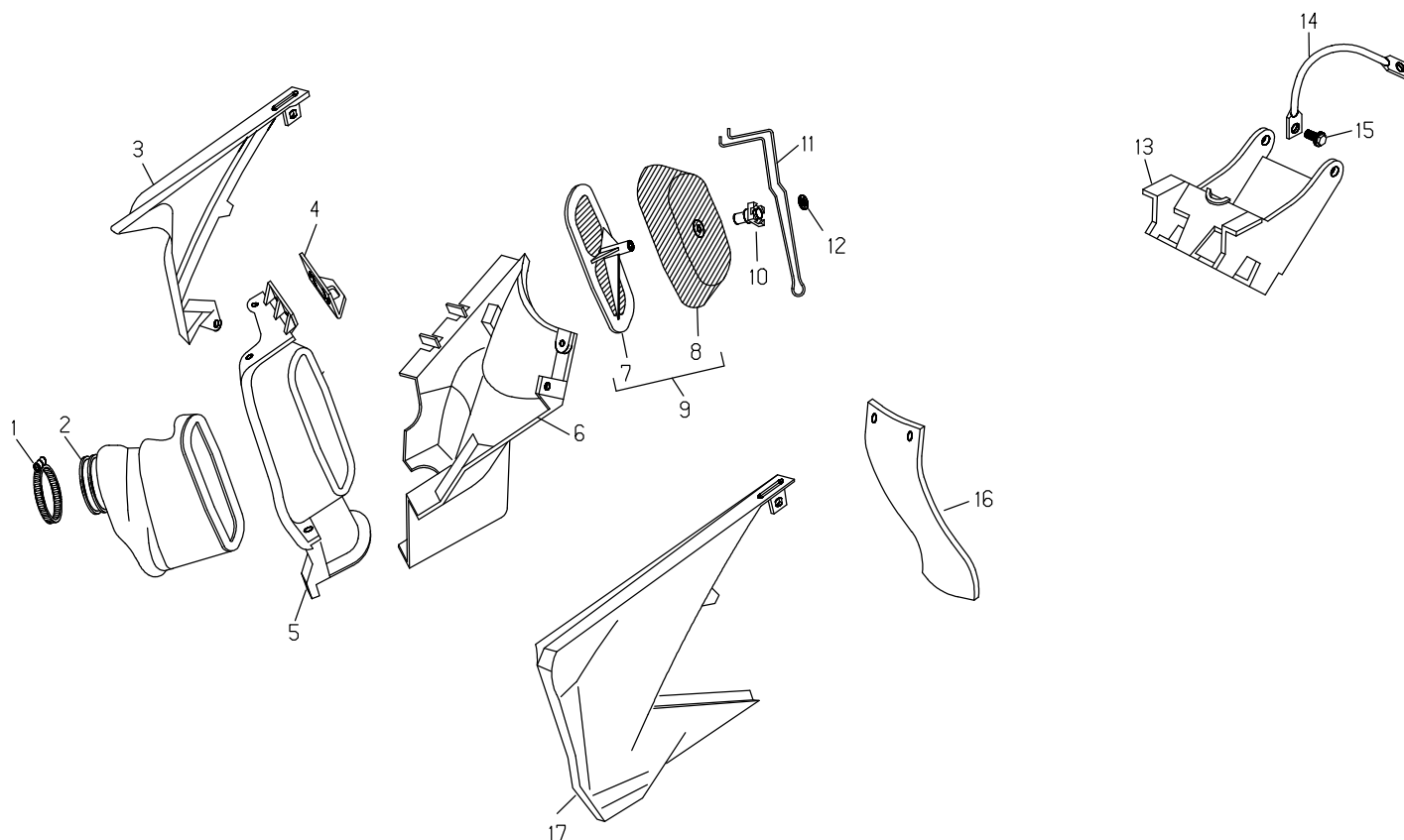

Pos	Number	Descrizione	Description	Description	Beschreibung	Descripción
1	15-14272	Fascetta raccordo aspiraz.	Clamp	Collier fixation	Schelle	Brida fijacion
2	22-13651	Manicotto scatola filtro	Rubber sleeve	Douille boite de filtre	Gummischlauch verga-luftfilter	Manguito caja filtro
3	28-12753-1-36	Scatola filtro dx	RH filter box	Boite de filtre droit	Filterkasten rechts	Caja filtro derecho
4	28-97021	Staffa aggancio molla filtro	Filter spring bracket	Etrier ressort filtre	Halter Federsfilter	Soporte muelle filtro
5	28-12751-1-36	Scatola filtro anteriore	Front filter box	Boite de filtre avant	Filterkasten vorne	Caja filtro anterior
6	28-12752-1-36	Scatola filtro posteriore	Rear filter box	Boite de filtre arriere	Filterkasten hinten	Caja filtro posterior
7	16-11215-8	Gabbia filtro aria	Filter cage	Grille filtre aire	Filter kafig	Jaula filtro aire
8	15-25091	Filtro aria	Air filter	Filtre aire	Luftfilter	Filtro aire
9	15-25091	Filtro aria	Air filter	Filtre aire	Luftfilter	Filtro aire
10	25-57197	Perno richiamo ferma-filtro	Filter pin	Pivot filtre	Filtershalter Pin	Eje filtro
11	22-48817	Molla fermafiltro	Filter spring	Ressort filtre	Filter Feder	Muelle filtro
12	27-74800	Rondella autobloccante 9	Washer 9	Rondelle 9	Scheibe 9	Arandela 9
13	28-11792-1-59	Scatola portabatteria	Battery box	Boite porte-batterie	Batteriekasten	Escatula bateria
14	18-01527	Impianto cavo massa	Electric equipment	Systeme electrique	Kabelbaum	Instalacion cable masa
15	11-48025	Bullone 6x16 ch 8 rs	Bolt 6x16	Boulon 6x16 ch8 rs	Bolzen 6x16	Tornillo 6x16 llave 8 rs
16	25-24413-1-59	Parascizzi scatola filtro	Filter box mudguard	Cache-taches boite de filtre	Spritzschutz Luftfilter	Faldon goma caja filtro
17	28-12754-1-36	Scatola filtro sx	LH filter box	Boite de filtre gauche	Filterkasten links	Caja filtro izquierdo

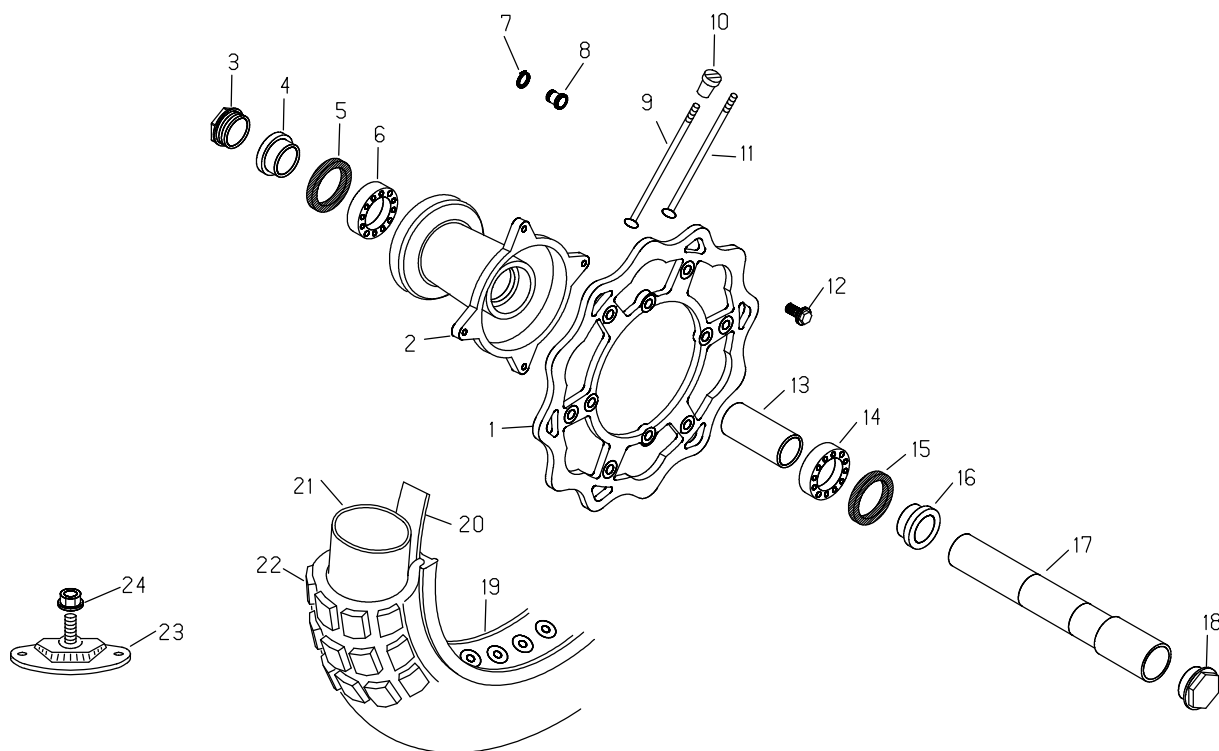

Pos	Number	Descrizione	Description	Description	Beschreibung	Descripción
1	13-39578	Disco freno anteriore	Front brake disk	Disque frein avant	Bremsscheibe vo.	Disco trial delantero
2	22-07249	Mozzo anteriore c/cuscinetti	Front hub with ballbearing	Moyeu avant avec roulements	Nabe vo.	Buje ant.c/cojinetes
3	29-10033	Tappo filett. perno ruota ant.	Front wheel pin plug	Bouchon pivot roue avant	Stopfen Pin Vorrad	Tapon eje ruoda anterior
4	13-85519	Distanziale mozzo ant. Sx/Dx	LH and RH front hub spacer	Entretoise moyeu avant	Distanz li/re	Dist.,buje delt.04 izq. l/disco
5	10-66000	Anello paraolio 35x47x7	Oil seal 35x47x7	Joint spy 35x47x7	Wedi 35x47x7	Junta aceite 35x47x7
6	12-99520	Cuscinetto 30x47x9	Ball Bearing 30x47x9	Roulement 30x47x9	Kurbelwellenlager 30x47x9	Cojinete 30x47x9
7	28-22570	Seeger RA5	Seeger RA5	Seeger RA5	Seegerring RA5	Seeger RA5
8	22-11001	Magnete per sensore REED	Sensor REED magneto	Magneto capteur REED	Magnet für Sensor	magneto sensor REED
9	27-25051	Raggio 4x227	Spoke 4x227	Rayon 4x227	Speiche 4x227	Rayo 4x227
10	23-10122	Nipples M5/4,50	Nipples M5/4,50	Nipples M5/4,50	Nippel M5/4,50	Nipples M5/4,50
11	27-25052	Raggio 4x230	Spoke 4x230	Rayon 4x230	Speiche4x230	Rayo 4x230
12	11-52520	Bullone 8x14	Bolt 8x14	Boulon 8x14	Schraube 8x14	Tornillo 8.14
13	13-62708	Distanziale int. mozzo anter.	Front hub inner spacer	Entretoise int. moyeu avant	Distanzscheibe	Distanciador int buje del.
14	12-99520	Cuscinetto 30x47x9	Ball Bearing 30x47x9	Roulement 30x47x9	Kurbelwellenlager 30x47x9	Cojinete 30x47x9
15	10-66000	Anello paraolio 35x47x7	Oil seal 35x47x7	Joint spy 35x47x7	Wedi 35x47x7	Junta aceite 35x47x7
16	13-85519	Distanziale mozzo ant. Sx/Dx	LH and RH front hub spacer	Entretoise moyeu avant	Distanz li/re	Dist.,buje delt.04 izq. l/disco
17	25-55697	Perno ruota anteriore	Front wheel pin	Pivot roue avant	Vorderradachse	Eje ruoda anterior
18	29-10032	Tappo perno ruota anteriore	Front wheel pin plug	Bouchon pivot roue avant	Stopfen Pin Vorrad	Tapon eje ruoda anterior
19	12-42901	Cerchio 21x1,6x36 fori	Rim 21x1,6x36	Jante 21x1,6x36	Felge 21x1,6x36	Llanta 21x1,6x36
20	15-38200	Flap 21x25	Bead 21x25	Flap21x25	Felgenband 21x25	Flap cinta tapa radios 21.25
21	12-15005	Camera 2,50x21-2,75x21	Tube 2,50x21-2,75x21	Tube 2,50x21-2,75x21	Schlauch 2,50x21-2,75x21	Camara 2,50x21-2,75x21
22	12-81575	Copertura 90/90x21	Tire 90/90x21	Couverture 90/90x21	Reifen 90/90x21	Cubierta 90/90x21
23	15-17551	Fermafascioni per cerchio 21	Tire fastener	Caoutchouc serrure chambre	Reifen Halter	Agarre cubierta ant.
24	13-17120	Dado M8 flangiato	Nut M8	Ecrou M8	Mutter M8	Tuerca M8

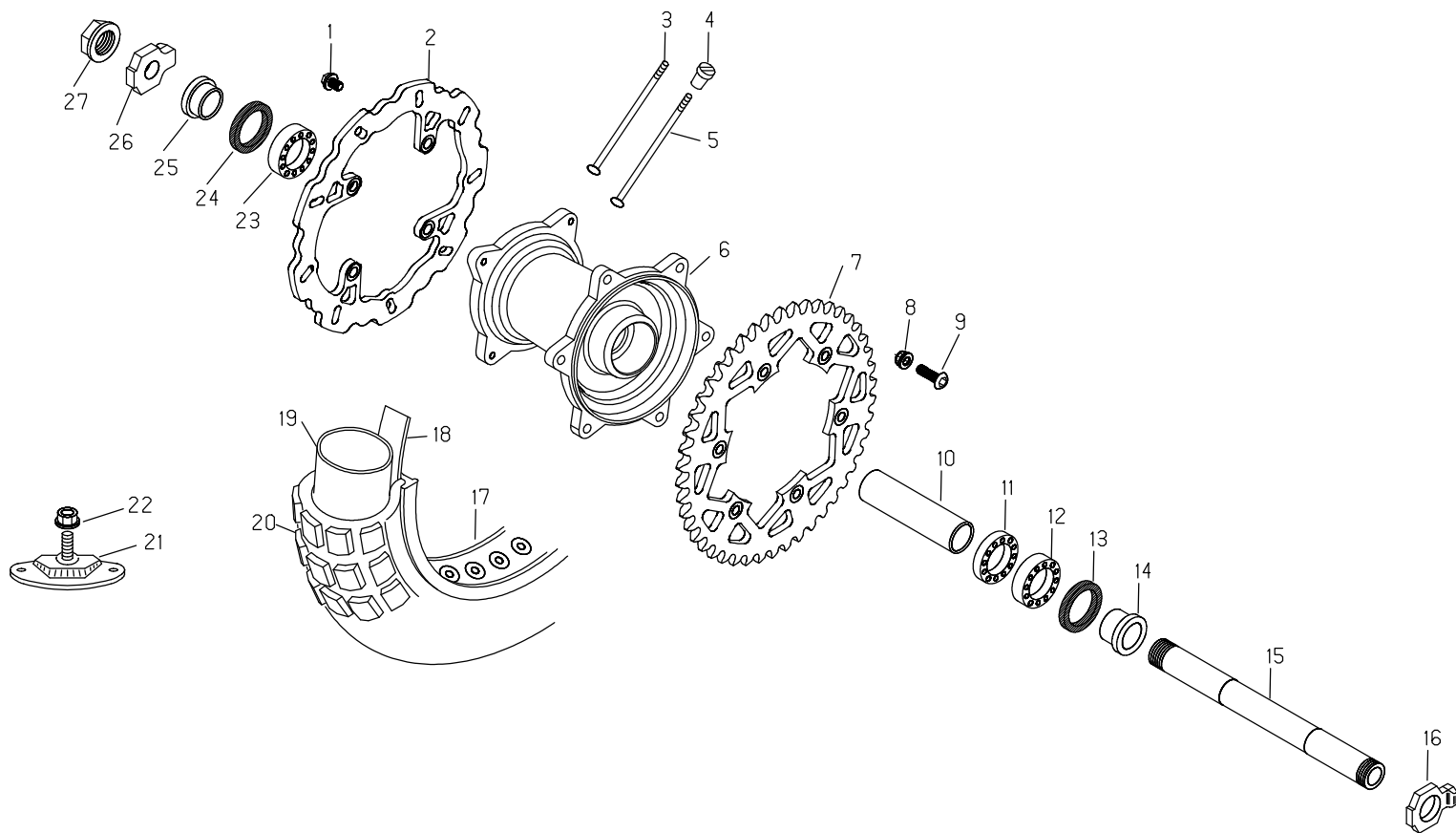

Pos	Number	Descrizione	Description	Description	Beschreibung	Descripción
1	11-52520	Bullone 8x14	Bolt 8x14	Boulon 8x14	Schraube 8x14	Tornillo 8.14
2	13-39574	Disco freno posteriore	rear brake disk	Disque frein arriere	Bremscheibe hi.	Disco trial trasero
3	27-25053	Raggio 4x190	Spoke 4x190	Rayon 4x190	Speiche 4x190	Rayo 4x190
4	23-10122	Nipples M5/4,50	Nipples M5/4,50	Nipples M5/4,50	Nippel M5/4,50	Nipples M5/4,50
5	27-25054	Raggio 4x196	Spoke 4x196	Rayon 4x196	Speiche 4x196	Rayo 4x196
6	22-08027	Mozzo posteriore c/cuscinetti	Rear hub with ballbearing	Moyeu arriere avec roulements	Hinterrad Nabe	Buje del. c/cojinetes
7	12-89496	Corona z.48	Rear sprocket z.48	Couronne z.48	Kettenrad z.48	Corona z-48
	12-89497	Corona z.50	Rear sprocket z.50	Couronne z.50	Kettenrad z.50	Corona z-50
	12-89498	Corona z.52	Rear sprocket z.52	Couronne z.52	Kettenrad z.52	Corona z-52
	12-89499	Corona z.45	Rear sprocket z.45	Couronne z.45	Kettenrad z.45	Corona z-45
8	13-17123	Dado M8 flangiato	Nut M8	Ecrou M8	Mutter M8	Tuerca M8
9	31-96815	Vite TSBCE 10x9	Screw	Vis	Schraube	Tornillo
10	13-62709	Distanziale int. mozzo poster.	Rear hub inner spacer	Entretoise int. moyeu arriere	Distanzscheibe	Distanciador int. Buje tras.
11	12-99260	Cuscinetto 25x47x8	Ball bearing 25x47x8	Roulement 25x47x8	Lager 25x47x8	Cojinete 25x47x8
12	12-99280	Cuscinetto 25x47x12	Ball bearing 25x47x12	Roulement 25x47x12	Lager 25x47x12	Cojinete 25x47x12
13	10-66000	Anello paraolio 35x47x7	Oil seal 35x47x7	Joint spy 35x47x7	Wedi 35x47x7	Junta aceite 35x47x7
14	13-85522	Distanziale mozzo post. Sx	LH rear hub spacer	Entretoise moyeu arriere	Distanz li	Distanciador buje tras.
15	25-55812	Perno ruota posteriore	Rear wheel pin	Pivot roue arriere	Hintenradachse	Eje rueda posterior
16	29-11866-1	Tendicatena sx	LH chain tensioner	Tendeur de chaine gauche	Kettenspanner li.	Tensor cadena izquierdo
17	12-42902	Cerchio 18x2,15x36 fori	Rim 18x2,15x36	Jante 18x2,15x36	Felge 18x2,15x36	Llanta 18x2,15x36
18	15-36000	Flap 17/18x25	Bead 17/18x25	Flap 17/18x25	Felgenband 17/18x25	Flap cinta tapa radios 17/18x25
19	12-15006	Camera 4,00x18	Tube 4,00x18	Tube 4,00x18	Schlauch 4,00x18	Camara 4,00x18
20	12-81584	Copertura 4,00x18	Tire 4,00x18	Couverture 4,00x18	Reifen 4,00x18	Cubierta 4,00x18
21	15-17531	Fermafascioni per cerchio 38	Tire fastener	Caoutchouc serrure chambre	Reifen Halter	Agarre cubierta ant.
22	13-17120	Dado M8 flangiato	Nut M8	Ecrou M8	Mutter M8	Tuerca M8
23	12-99280	Cuscinetto 25x47x12	Ball bearing 25x47x12	Roulement 25x47x12	Lager 25x47x12	Cojinete 25x47x12
24	10-66000	Anello paraolio 35x47x7	Oil seal 35x47x7	Joint spy 35x47x7	Wedi 35x47x7	Junta aceite 35x47x7
25	13-85521	Distanziale mozzo post. Dx	RH rear hub spacer	Entretoise moyeu arriere	Distanz li	Distanciador buje tras.
26	29-11865-1	Tendicatena dx	RH chain tensioner	Tendeur de chaine droit	Kettenspanner re.	Tensor cadena derecho
27	13-27120	Dado spec. perno ruota post.	Rear wheel axle special nut	Ecrou spec. Pivot roue arr.	Spezial Mutter Rad hinten	Tuerca esp. Rueda posterior

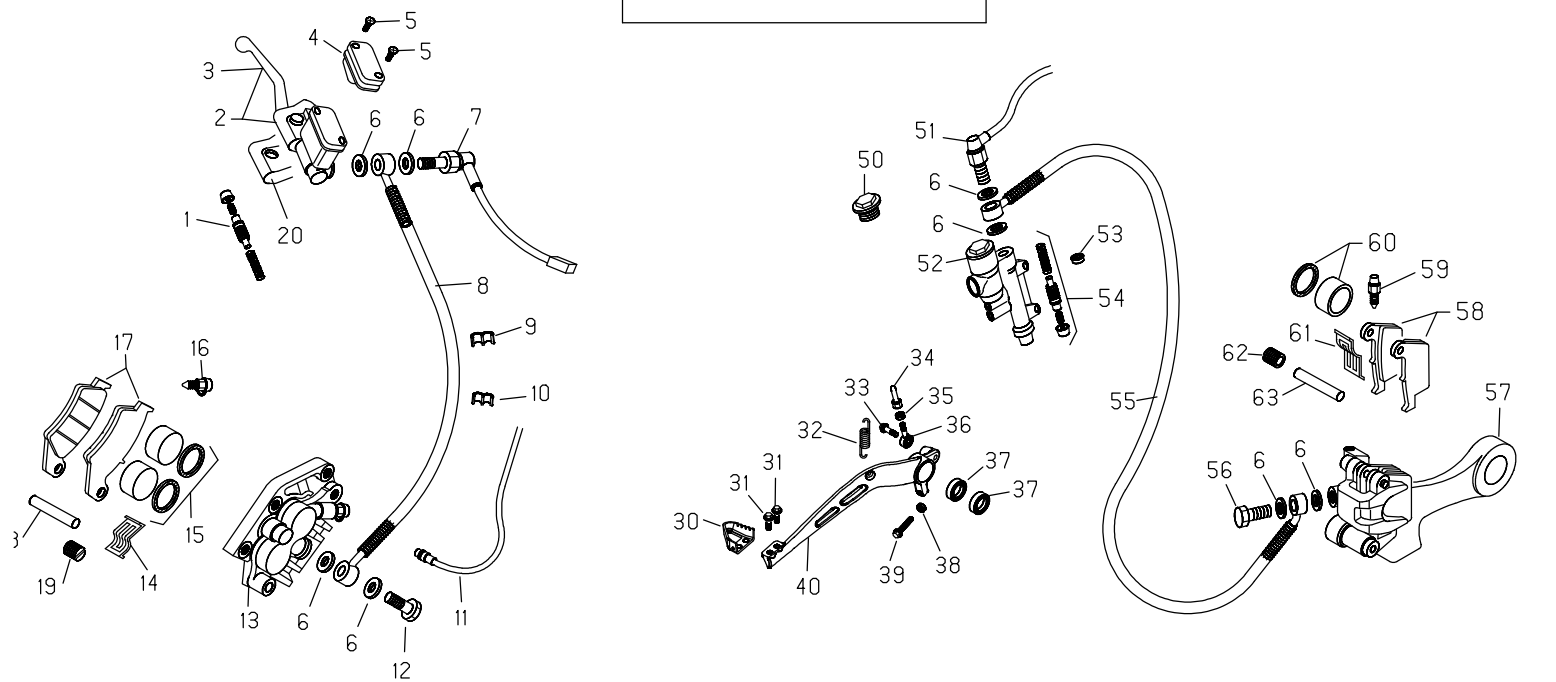

Pos	Number	Descrizione	Description	Description	Beschreibung	Descripción
1	20-08258	Kit pistoncino compl. pompa	Pump piston assy	Jeu piston complet pompe	Kuppl. pompe kolben	Juego piston compl. Bomba
2	21-02057	Leva com. freno anter.	Front brake lever	Levier complet frein avant	Bremsarmatur	Bomba freno delantero
3	21-27104	Leva freno anter.nuda	Front brake lever only	Levier frein avant nue	Bremshebel	Maneta freno
4	20-08259	Kit coperchio serbatoio pompa	Pump tank cover assy	Jeu couvercle reservoir pompe	Reparaturatz Deckel Pumpe	Tubo tapon deposito bomba
5	31-23402	Vite coperchio serbatoio olio	Screw	Vis couvercle reservoir huile	Schraube	Tornillo tapa deposito aceite
6	16-50510	Guarnizione 10x15x1 in rame	Gasket 10x15x1 copper	Joint 10x15x1 cuivre	Dichtung 10x15x1 Kupfer	Junta 10.15.1 (cobre)
7	18-89621	Interruttore stop	Stop switch	Intermittence stop	Stopplichtschalter	Interruptor stop/arranque
8	29-09101	Tubo freno anteriore	Front brake hose	Tube frein avant	Bremsleitung	Tubo freno delantero
9	25-24443	Passacavo 6/6	Fair lead 6/6	Passe-fils 6/6	Kabelführung 6/6	Pasa-cable 6/6
10	25-24442	Passacavo 6/8	Fair lead 6/8	Passe-fils 6/8	Kabelführung 6/8	Pasa-cable 6/8
11	28-79011	Sensore REED	REED sensor	Sensor REED	Sensor	Sensore REED
12	11-65053	Bullone forato 10x1,25	Special bolt	Boulon 10x1,25 x tube frein	Hohlschraube F.Bremse	Tornillo esp. talad.10.1,25
13	25-03056	Pinza freno anteriore	Front brake pleir	Pince frein avant	Bremszange vorne	Pinza freno anterior
14	22-32207	Molla ferma pastiglie pinza	Brake pads spring for pliers	Ressort arret plaquettes	Haltefeder	Muelle pastillas pinza
15	20-02716	Kit pistoncini e guarniz. Pinza	Piston e oil seal for pliers	Jeu petit pistons et joint pinces	Reparaturatz Bremszange	Juego piston y guarnicion pinza
16	28-91001	Sfiato pinza freno	Breather pipe	Event pince frein	Bremszange Entlüftung	Aliento pinzas freno
17	25-25361	Pastiglie per pinza	Brake pads	Plaquettes pince	Bremsbeläge hinten	Pastillas pinza
18	25-41859	Perno ancoraggio pastiglia	Pin hanger	Pivot ancrage	halter bremsbelage	Varilla esp. Pastillas pinzas
19	31-96821	Vite spec. Perno pinza	Pin plug	Vis special pince frein	Spezialschraube bremszange vo	Tornillo esp. Pastillas pinzas
20	16-33841	Gommino coprileva	Grommet	Caoutchouc couvre-levier	Gummi	Goma
30	22-90053	Mozzetto con pedana	Footrest hub	Moyeu a/repose pieds	Rasten Nabe Fußbremshebel	Puntera pedal freno
31	11-46251	Bullone 5x12 ch 8	Bolt 5x12	Boulon 5x12 ch 8	Bolzen 5x12	Tornillo 5x12 llave 8
32	22-48813	Molla ritorno pedale freno	Return brake pedal spring	Ressort de retour frein	Bremspedal Feder	Muelle retorno palanca freno
33	11-50010	Bullone 6x25 ch 8 rs	Bolt 6x25	Boulon 6x25 ch 8 rs	Bolzen 6x25	Tornillo 6.25 ch 8 rs
34	10-84094	Asta com.pompa freno post.	Rear brake rod	Tige de commande pompe frein	Betaetigungsstange Bremse hi.	Varilla bomba freno post.
35	13-11500	Dado 6x3,5 ch10	Nut 6x3,5	Ecrou 6x3,5 ch10	Mutter 6x3,5	Tuerca 6x3,5 llave 10
36	28-93254	Snodo sferico per asta freno	Brake bracket spheric junction	Joint a rotule etrier frein	Kugelgelenk	Rotula esferica asta freno
37	12-93388	Cuscinetto 8x22x7	Ball bearing 8x22x7	Roulement 8x22x7	Kugellager 8x22x7	Cojinete 8x22x7
38	13-13020	Dado autoblocc. Basso M6	Nut M6	Ecrou M6	Mutter M6	Tuerca M6
39	11-50030	Bullone 6x30 ch 8 rs	Bolt 6x30	Boulon 6x30 ch 8 rs	Bolzen 6x30	Tornillo 6.30 ch 8 rs
40	25-28087	Pedale freno	Rear brake	Pedale frein	Bremshebel hi.	Pedal freno
50	20-08263	Kit tappo compl. pompa freno	Brake pump complete cover kit	Jeu couvercle complete pompe frein	Reparaturatz Deckel Bremspumpe	Juego tapon completo bomba freno
51	18-89622	Interruttore stop	Stop switch	Intermittence stop	Stopplichtschalter	Interruptor stop/arranque
52	25-91176	Pompa freno posteriore	Rear brake pump	Pompe frein arriere	Bremspumpe hi.	Bomba freno trasera
53	10-67335	Anello OR pompa freno	Brake pump OR	OR pompe de frein	O-Ring Bremspumpe	Junta torica bomba freno
54	20-08264	Kit pistoncino pompa freno	Brake pump piston kit	Jeu piston pompe frein	Reparaturatz Kolben Bremspumpe	Juego piston bomba freno
55	29-09427	Tubo freno disco posteriore	Rear brake hose	Tube frein a disque arriere	hi. Bremsleitung	Tubo freno disco post.
56	11-65053	Bullone forato 10x1,25	Special bolt	Boulon 10x1,25 x tube frein	Hohlschraube F.Bremse	Tornillo esp. talad.10.1,25
57	25-03066	Pinza freno posteriore	Pliers front brake	Pince frein arriere	Bremszange hinten	Pinza freno post.
58	25-25362	Pastiglie per pinza	Brake pads	Plaquettes pince	Bremsbeläge hinten	Pastillas pinza
59	28-91002	Sfiato pinza freno	Breather pipe	Event pince frein	Bremszange Entlüftung	Aliento pinzas freno
60	20-02717	Kit pistoncini e guarniz. Pinza	Piston e oil seal for pliers	Jeu petit pistons et joint pinces	Reparaturatz Bremszange	Juego piston y guarnicion pinza
61	22-32208	Molla ferma pastiglie pinza	Brake pads spring for pliers	Ressort arret plaquettes	Haltefeder	Muelle pastillas pinza
62	31-96821	Vite spec. Perno pinza	Pin plug	Vis special pince frein	Spezialschraube bremszange vo	Tornillo esp. Pastillas pinzas
63	25-41860	Perno ancoraggio pastiglia	Pin hanger	Pivot ancrage	Halter Bremsbelage	Varilla esp. Pastillas pinzas



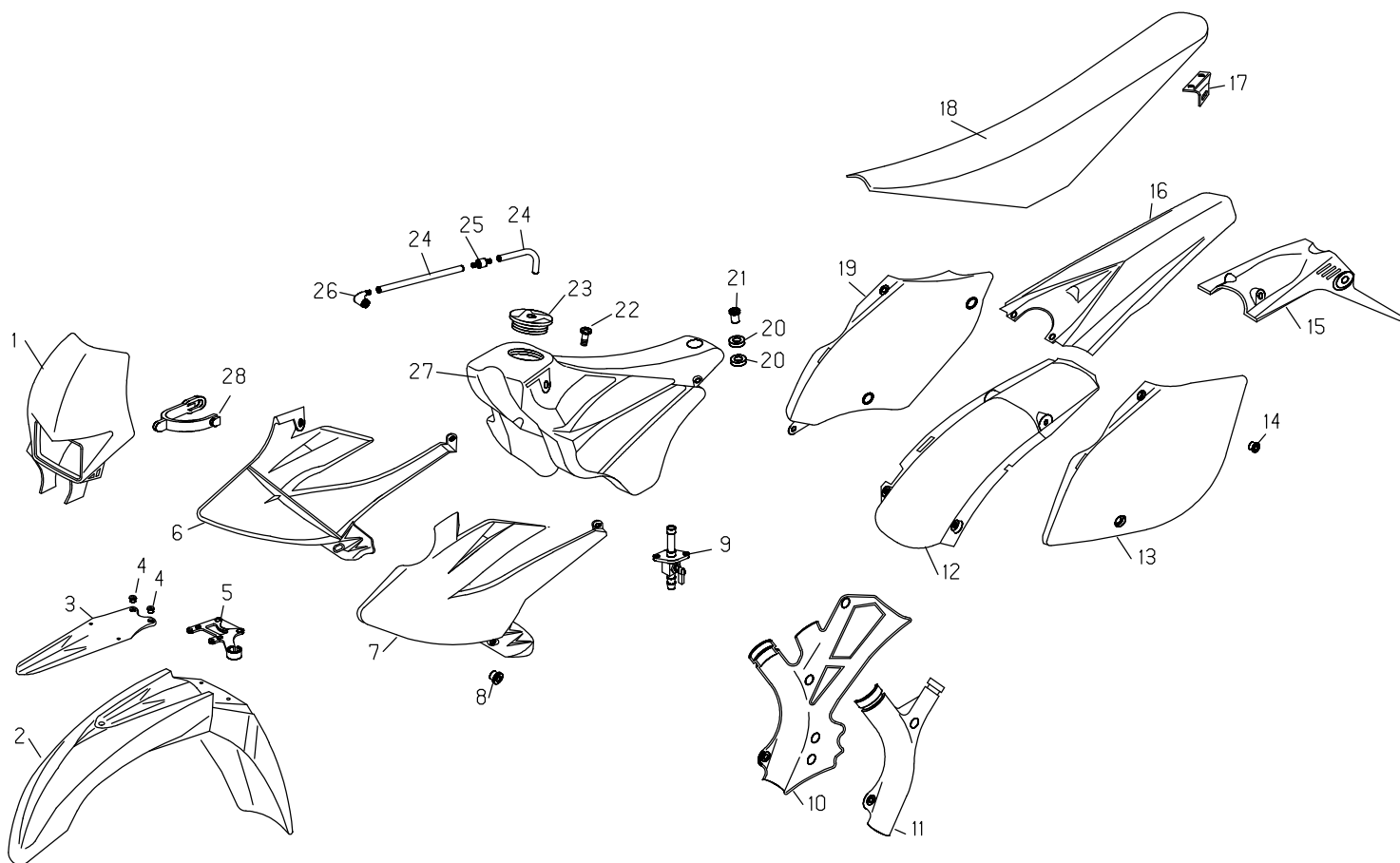

Pos	Number	Descrizione	Description	Description	Beschreibung	Descripción
1	22-28471-1-97	Mascherina portafaro	Headlight holder	Cache porte-phare	Lampenmaske	Portafaro ant. con adesivo
2	25-15201-1-97	Parafango anteriore	Front fender	Garde-boue avant	Vorderradkotflügel	Guardabarros delantero
3	28-98278-1-33	Supporto parafango anteriore	Front fender bracket	Support garde-boue avant	Kotflügelhalter vorne	Soporte guardabarros ant.
4	13-49190	Distanziale	Spacer	Entretoise	Distanz	Distanciador
5	25-57255-1-36	Piastra per tubo freno anter.	Front brake tube plate	Plaque tube frein avant	Halteplatte Bremsschlauch	Placa tubo freno anterior
6	15-23203-1-97	Fianchetto serbatoio dx	RH tank panel	cote lateral reservoir droite	Benzintankseite re.	Flanco derecho deposito
7	15-23202-1-97	Fianchetto serbatoio sx	LH tank panel	Cote lateral reservoir gauche	Benzintankseite li.	Flanco izquierdo deposito
8	13-54820	Distanziale 6,5/9/13,5x4,8	Spacer	Entretoise	Distanz	Distanciador
9	27-79831	Rubinetto benzina	Petcock	Robinet melange	Benzinhahn	Grifo gasolina
10	25-98925	Protezione telaio dx	RH frame protection	Protection cadre droit	Rahmenschutz re.	Protection chasis derecho
11	25-98926	Protezione telaio sx	LH frame protection	Protection cadre gauche	Rahmenschutz li.	Protection chasis izquierdo
12	25-24657-1-36	Passaruota	Rear wheel house	Passe-roue	Radführung	Pasarueda
13	15-19863-1-97	Fiancata portanumero sx	LH side panel	Cote lateral gauche porte-numero	Nummershalterseite li.	Flanco lateral izquierdo
14	13-62000	Distanziale	Spacer	Entretoise	Distanz	Distanciador
15	25-94486-1-36	Portatarga	Number plate holder	Porte-plaque	Nummernschildhalter	Porta-matricula
16	25-19586-1-97	Parafango posteriore	Rear fender	Garde-boue arriere	Hinterradkotflügel	Guardabarros tras.
17	28-95233	Staffa fissaggio sella	Fixing seat plier	Etrier fixation selle	Halter Sattel	Soporte fijacion sillin
18	28-02651	Sella	Seat	Selle	Sattel	Sillin
19	15-19862-1-97	Fiancata portanumero dx	RH side panel	Cote lateral droite porte-numero	Nummershalterseite re.	Flanco lateral derecho
20	29-10615	Tampon carena scooter	Scooter fairing pad	Tampon carenage scooter	Rolleraufbau Schlegel	Tampon casco del buque scooter
21	13-49184	Distanziale serbatoio	Tank spacer	Entretoise reservoir	Distanz Benzintank	Distanciador deposito
22	31-89010	Vite spec. bloccaggio sella	Seat locking screw	Vis blocage selle	Schraube	Tornillo bloqueo sillin
23	29-10501	Tappo serb. benzina	Gasoline tank plug	Bouchon reservoir	Tankdeckel	Tapon deposito gasolina
24	29-15811	Tubo benzina 5x9	Gasoline tube 5x9	Tube essence 5x9	benzinschlauch 5x9	Tubo gasolina 5x9
25	31-02170	Valvola sfiato serbatoio	Tank exhaust valve	Valve echappement reservoir	Entlüftungssicherung Tank	Valvula escape deposito
26	27-23470	Raccordo per sfiato	Breather pipe hose	Raccord pour event	Entlüftungsschlauch	Enlace aliento
27	28-06078-1	Serbatoio benzina	Gasoline tank	Reservoir	Benzintank	Deposito gasolina
28	14-40081	Elastico fissaggio mascherina	Headlight holder elastic rubber	Elastique de fixation cache phare	Befestigungsband Lichtschildche	Elastico

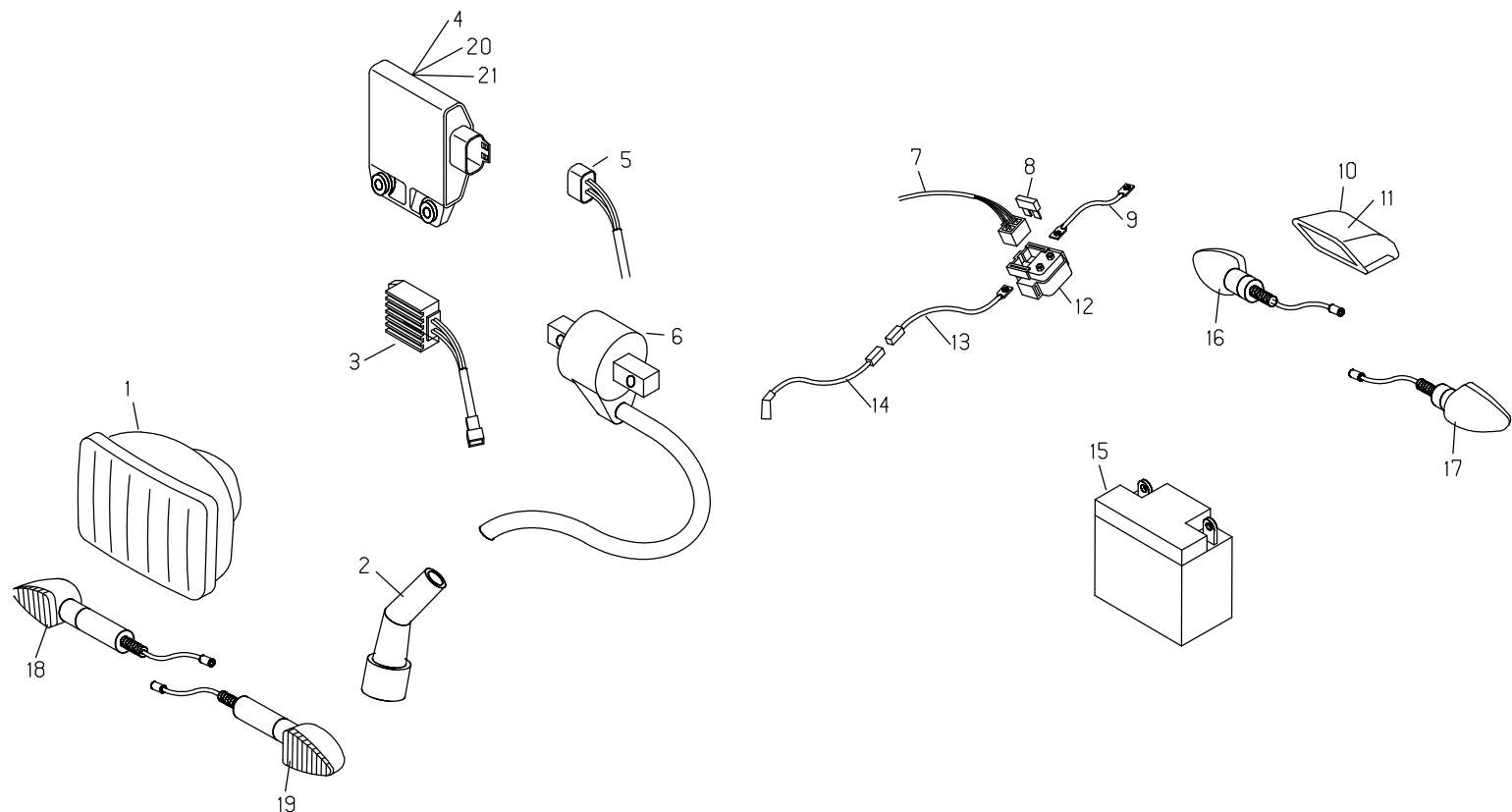

Pos	Number	Descrizione	Description	Description	Beschreibung	Descripción
1	16-46202	Gruppo ottico RR-4T	Headlight RR4T	Groupe optique	Optischer Block	Grupo optico
	16-46203	Gruppo ottico RR-4T	Headlight	Groupe optique	Scheinwerfer supermotard	Grupo optico RR-4T
2	27-13553	Raccordo candela	Spark plug raccor	Raccord bugie	Zündkerzenstecker	Enlace bujia
3	27-28101	Regolatore	Regulator	Regulateur	Regler	Regulador
4	12-41847-8	Centralina digitale con targh.	CDI unit	CDI	CDI mit Schild	CDI
5	18-01536	Impianto centralina	CDI electric equipment	CDI systeme électrique	CDI Kabelbaum	Instalacion CDI
6	11-20694-8	Bobina con targhetta	Coil with plate	Bobine avec plaquette	Zündspule mit Schild	Bobina con placa
7	18-01537	Impianto posteriore	rear electric equipment	systeme électrique arriere	Kabelbaum hi.	Instalacion posterior
8	15-66601	Fusibile 10A	Fuse 10A	Fusible 10A	Schmelzsicherung	Fusible 10A
9	18-01529	Impianto cavo positivo batteria	Electric equipment	Systeme électrique	Kabelbaum	Instalacion cable positivo bateria
10	15-01766	Fanalino posteriore	Rear light	feu arriere	Rücklicht Glas	Piloto trasero
11	12-81703	Coppetta fanalino posteriore	Indicator lens	Boite feu arriere	Rücklichtschutz	Proteccion luz posterior
12	27-28471	relais avviamento motore	Starter relais	Relais demarrage	Relais Starter	Relais arranque
13	18-01528	Impianto relè	Electric equipment	Systeme électrique relais	Kabelbaum	Instalacion relais
14	18-01538	Impianto motorino avviamento	starter electric equipment	system électrique demarrage	Kickstarter Kabelbaum	Instalacion arranque
15	11-15415	Batteria	Battery	Batterie	Batterie	Bateria
16	18-12621	Indicatore direzione post. dx	RH rear indicator	Indicateur arriere droit	Blinker hinten re.	flecha posterior derecha
17	18-12624	Indicatore direzione post. sx	LH rear indicator	Indicateur arriere gauche	Blinker hinten li.	flecha posterior izquierda
18	18-12611	Indicatore direzione ant. dx	RH front indicator	Indicateur avant droit	Blinker vorne re.	Flecha anterior derecha
19	18-12614	Indicatore direzione ant. sx	LH front indicator	Indicateur avant gauche	Blinker vorne li.	flecha anterior izquierda

PER 450cc - FOR 450cc - POUR 450cc - FUER 450cc - POR 450cc

Pos	Number	Descrizione	Description	Description	Beschreibung	Descripción
20	12-41848-8	Centralina digitale con targh.	CDI unit	CDI	CDI mit Schild	CDI

PER 400/525cc - FOR 400/525cc - POUR 400/525cc - FUER 400/525cc - POR 400/525cc

Pos	Number	Descrizione	Description	Description	Beschreibung	Descripción
21	12-41849-8	Centralina digitale con targh.	CDI unit	CDI	CDI mit Schild	CDI

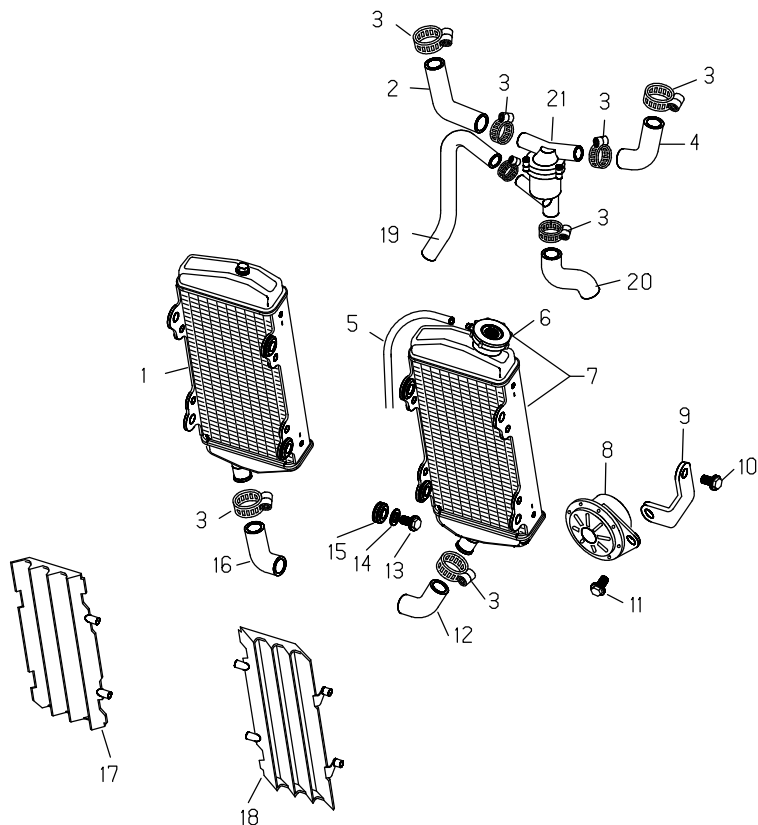

Pos	Number	Descrizione	Description	Description	Beschreibung	Descripción
1	27-23742	Radiatore dx	RH radiator	Radiateur droit	Kühler re.	Radiador derecho
2	29-15934	Tubo radiatore dx	RH radiator tube	Tube radiateur droit	Wasserschlauch Kühler re.	Tubo radiador derecho
3	15-15240	Fascetta 19x28	Clamp 19x28	Collier 19x28	Schelle 19x28	Brida 19/28
4	29-15933	Tubo radiatore sx	LH radiator tube	Tube radiateur gauche	Wasserschlauch Kühler li.	Tubo radiador izquierdo
5	29-15811	Tubo benzina 5x9	Gasoline tube 5x9	Tube essence 5x9	benzinschlauch 5x9	Tubo gasolina 5x9
6	29-01823	Tappo radiatore	Water tank cover	Bouchon radiateur	Kühlwasserdeckel	Tapon radiador
7	27-23743	Radiatore sx	LH radiator	Radiateur gauche	Kühler li.	Radiador izquierdo
8	10-09172	Avvisatore acustico	Horn	Avertisseur acoustique	Hupe	Avisador acustico
9	28-97255	Staffa supporto avvisat. acust.	horn support bracket	Etrier support clacson	Klemme Hupe	Soporte clacson
10	11-47015	Bullone 6x12 ch 8 rs	Bolt 6x12	Boulon 6x12 ch 8 rs	Bolzen 6x12	Tornillo 6x12 llave 8 rs
11	11-47015	Bullone 6x12 ch 8 rs	Bolt 6x12	Boulon 6x12 ch 8 rs	Bolzen 6x12	Tornillo 6x12 llave 8 rs
12	29-15935	Tubo inferiore radiatore sx	LH lower radiator tube	Tube radiateur gauche inf.	Wasserschlauch Kühler unten/re.	Tubo radiador izquierdo inferior
13	11-47015	Bullone 6x12 ch 8 rs	Bolt 6x12	Boulon 6x12 ch 8 rs	Bolzen 6x12	Tornillo 6x12 llave 8 rs
14	27-42000	Rondella 6x18	Washer 6x18	Rondelle 6x18	Scheibe 6x18	Arandela 6x18
15	16-34911	Gommino radiatore	Radiator rubber	Caoutchouc radiateur	Kühler Gummi	Goma radiador
16	29-15936	Tubo inferiore radiatore dx	RH lower radiator tube	Tube radiateur droit inf.	Wasserschlauch Kühler unten/li.	Tubo radiador derecho inferior
17	16-45544-1-36	Griglia radiatore dx	RH radiator protection	Grille radiateur droite	Kühlergrill re.	Rejilla radiador derecha
18	16-45545-1-36	Griglia radiatore sx	LH radiator protection	Grille radiateur gauche	Kühlergrill li.	Rejilla radiador izquierda
19	29-15938	Tubo inferiore termostato	Lower thermostat tube	Tube inferieur interrupteur thermique	Thermostatschlauch unten	Tubo termostato inferior
20	29-15937	Tubo termostato	Thermostat tube	Tube interrupteur thermique	Thermostatschlauch	Tubo termostato
21	29-11991	Termostato completo	Complete thermostat	Interrupteur thermique complet	Kompletter Thermostat	Termostato completo

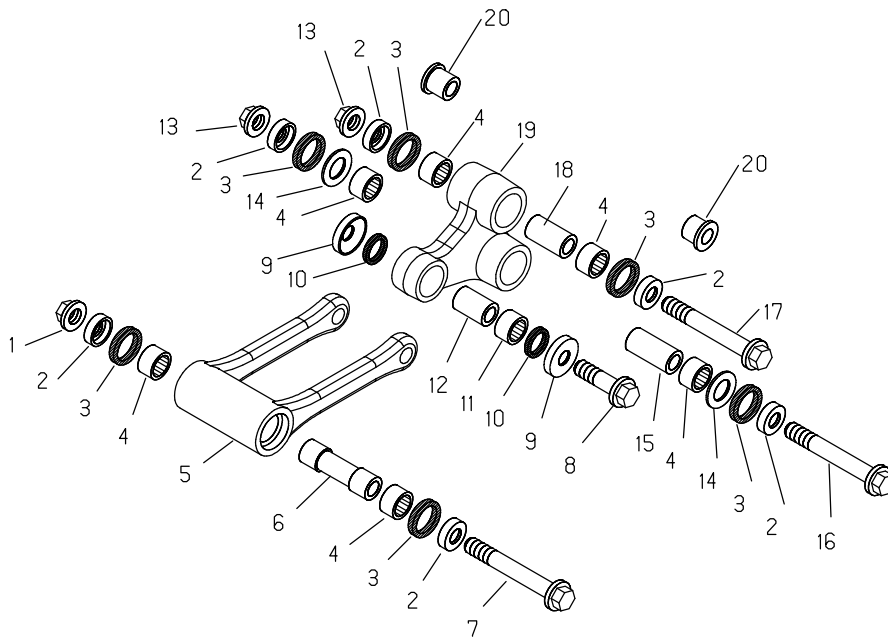

Pos	Number	Descrizione	Description	Description	Beschreibung	Descripción
1	13-21130	Dado autoblocc. flangiato 12	Nut 12	Ecrou 12	Mutter 12	Tuerca 12
2	28-14080	Scodellino bilanciante	Rocking lever cup	Cuvette balancier	Schwinghebel Teller	Sopero balance
3	10-64480	Anello paraolio 25x32x4	Oil seal 25x32x4	Joint spy 25x32x4	Wedi 25x32x4	Junta aceite 25x32x4
4	11-22055	Boccola a rulli 20x26x16	Needle bearing 20x26x16	Douille a roulements 20x26x16	Nadellager 20x26x16	Cojinete 20x26x16
5	11-19738	Bielletta	Connecting rod	Biellette	Pleuelstange	Biela
6	13-62814	Distanziale 12x20x77,5	Spacer 12x20x77,5	Entretoise 12x20x77,5	Distanz 12x20x77,5	Distanciador 12x20x77,5
7	11-63996	Bullone spec. Bilanciere	Bumper rod bolt	Boulon balancier	Spezial Schwinghebelsbolzen	Tornillo balance
8	11-62050	Bullone 10x45	Bolt 10x45	Boulon 10x45	Bolzen 10x45	Tornillo 10.45
9	28-14091	Scodellino bilanciante	Rocking lever cup	Cuvette balancier	Schwinghebel Teller	Sopero balance
10	10-62030	Anello paraolio 18x24x3	Oil seal 18x24x3	Joiny spy 18x24x3	Wedi 18x24x3	Junta aceite 18x24x3
11	11-22054	Boccola a rulli 18x24x16	Needle bearing 18x24x16	Douille a roulements 18x24x16	Nadellager 18x24x16	Cojinete 18x24x16
12	13-47960	Distanziale 10x18x23	Spacer 10x18x23	Entretoise 10x18x23	Distanz 10x18x23	Distanciador 10.18.23
13	13-21130	Dado autoblocc. flangiato 12	Nut 12	Ecrou 12	Mutter 12	Tuerca 12
14	27-73635	Rondella spess. 20x30x1	Washer 20x30x1	Rondelle epaisseur 20x30x1	Scheibe 20x30x1	Arandela 20x30x1
15	13-62813	Distanziale 12x20x50	Spacer 12x20x50	Entretoise 12x20x50	Distanz 12x20x50	Distanciador 12x20x50
16	11-63992	Bullone spec. Bilanciere	Bumper rod bolt	Boulon balancier	Spezial Schwinghebelsbolzen	Tornillo balance
17	11-63995	Bullone spec. Bilanciere	Bumper rod bolt	Boulon balancier	Spezial Schwinghebelsbolzen	Tornillo balance
18	13-62812	Distanziale 12x20x40	Spacer 12x20x40	Entretoise 12x20x40	Distanz 12x20x40	Distanciador 12x20x40
19	11-20475	Bilanciere	Bumper rod	Balancier	Schwinghebel	Balance
20	11-22052	Boccola per forcellone	Swinging arm bush	Douille bras oscillant	Buchse für Schwinge	Casquillo basculante

PARTICOLARI NON FIGURANTI
 SUPPLEMENTARY OARTS LIST
 PARTICULIERS PAS MENTIONNES
 NICHT VERZECHNETE TEILE
 PARTICULARES NO FIGURADOS

Pos	Number	Descrizione	Description	Description	Beschreibung	Descripción
	11-05666	Borsetta arnesi	Tools bag	Sachocce avec outils	Werkzeugtasche	-
	12-33062	Catadiottro laterale	Lateral reflector	Catadioptré lateral	Seitlicher Rückstrahler	Reflector lateral
	12-33086	Catadiottro posteriore	Rear reflector	Catadioptré arriere	Rückstrahler hinten	Reflector posterior
	13-31462	Decalco (serie)	Transfer set	Serie decalco	Serie Aufkleber	Serie adhesivos
	20-09051	Kit getti carburatore RR-4T	Carburetor jets kit	Jeu jets carburateur	Reparatursatz Vergasersdüsen	Juego lanzamientos carburador
	20-11210	Kit protez. telaio in carbonio	Frame carbon protection kit	Jeu protections cadre en carbon	Kit Karbonrahmenschutz	Juego protect. Chasis en carbono
	20-11211	Kit distanziali targa	Number plate spacer kit	Jeu entretoises plaque	Kit Nummernschild Distanz	Juego distanciador matricula
	20-11212	Kit spugne protez. Telaio	Frame sponges protection kit	Jeu sponges protect. Cadre	Kit Schwamm Rahmenschutz	Juego esponjas protect. Chasis
	25-99215	Pulsante comando "MODE"	Pushbutton "MODE" digital speed	Pulsier commande "MODE"	Schalter "MODE"	Boton mando "MODE"
	27-02559-0-57	Ruota anteriore	Front wheel	Roue avant	Vorderrad	Rueda delantera
	27-02559-4-57	Ruota anteriore p/montata	Front wheel ass.	Roue avant p/monte'	Vormontiertes vorderrad	Rueda delantera montada
	27-04808-0-57	Ruota posteriore	Rear wheel	Roue arriere	Hinterrad	Rueda trasera
	27-04808-4-57	Ruota posteriore p/montata	Front wheel ass.	Roue arriere p/monte'	Vormontiertes hinterrad	Rueda trasera montada
	28-12755-8-36	Scatola filtro completa	Air filter box assembly	Boite de filtre complet monté	Filterkasten montiert	Caja filtro aire completa montada
	28-92927	Specchio retrovisore dx	RH rear view mirror	Retroviseur droit	Rückspiegel re.	Espejo retrovisor derecho
	28-92928	Specchio retrovisore sx	LH rear view mirror	Retroviseur gauche	Rückspiegel li.	Espejo retrovisor izquierdo
	28-98476	Supporto targa	Licenze plate bracket	Support plaque	Nummernschildhalter	Soporte matricula

MOTORE RR-4T 250-400-450-525CC
ENGINE, RR-4T 250-400-450-525CC
MOTEUR RR-4T 250-400-450-525CC
MOTOR, RR-4T 250-400-450-525CC
MOTOR, RR-4T 250-400-450-525CC

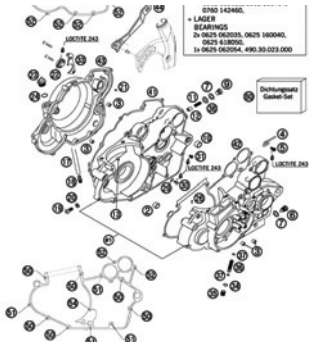
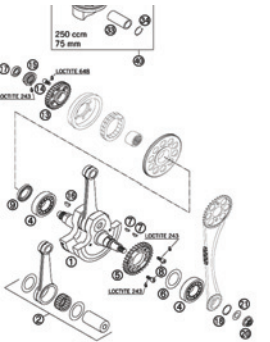
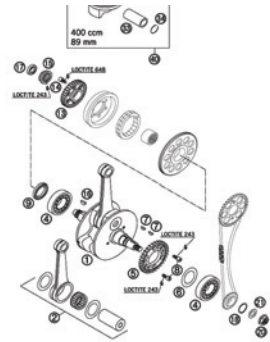
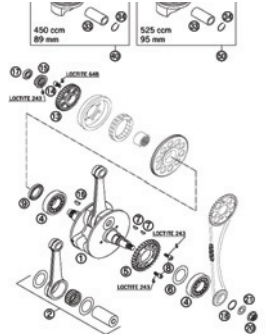
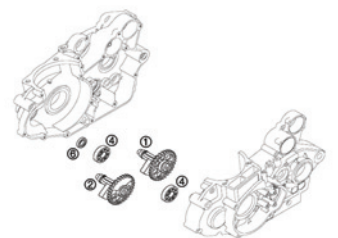
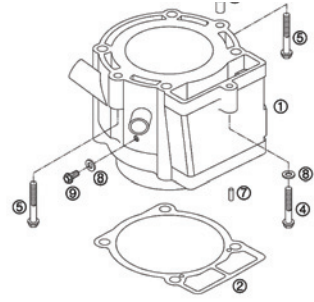
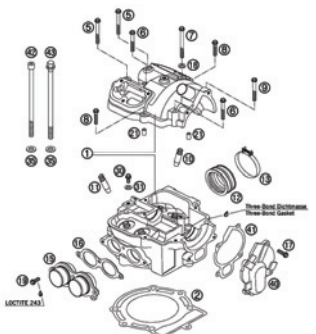
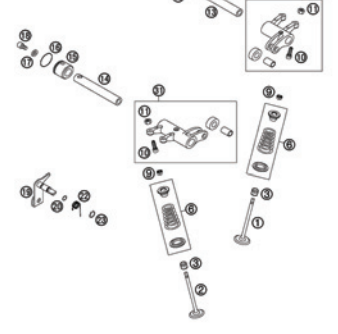
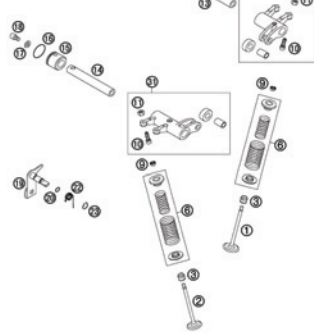
<p>TAV. 1 - CARTER MOTORE - ENGINE CASE - CARTER</p> <p>- MOTORGEHÄUSE - CARTER</p>	<p>TAV. 2 - ALBERO MOTORE E PISTONE - CRANKSHAFT - PISTON - VILEBREQUIN ET PISTON</p> <p>- KURBELWELLE - KOLBEN - CIGUENAL Y PYSTON</p>	<p>TAV. 3 - ALBERO MOTORE E PISTONE - CRANKSHAFT - PISTON - VILEBREQUIN ET PISTON</p> <p>- KURBELWELLE - KOLBEN - CIGUENAL Y PYSTON</p>
<p>250-400-450-525CC</p> 	<p>250CC</p> 	<p>400CC</p> 
<p>TAV. 4 - ALBERO MOTORE E PISTONE - CRANKSHAFT - PISTON - VILEBREQUIN ET PISTON</p> <p>- KURBELWELLE - KOLBEN - CIGUENAL Y PYSTON</p>	<p>TAV. 5 - ALBERO BILANCIAMENTO - BALANCER SHAFT - VILEBREQUIN BALANCER</p> <p>- AUSGLEICHSWELLE - CIGUENAL BALANCA</p>	<p>TAV. 6 - CILINDRO - CYLINDER - CYLINDRE</p> <p>- ZYLINDER - CILINDRO</p>
<p>450-525CC</p> 	<p>250-400-450-525CC</p> 	<p>250-400-450-525CC</p> 
<p>TAV. 7 - TESTA - CYLINDER HEAD - CULASSE</p> <p>- ZYLINDERKOPF - CULATA</p>	<p>TAV. 8 - ALBERO BILANCIAMENTO VALVOLE E VALVOLE - VALVE DRIVE - VILEBREQUIN BALANCER VALVES ET VALVES</p> <p>- VENTILTRIEB - CIGUENAL BALANCA VÁLVULES Y VÁLVULES</p>	<p>TAV. 9 - ALBERO BILANCIAMENTO VALVOLE E VALVOLE - VALVE DRIVE - VILEBREQUIN BALANCER VALVES ET VALVES</p> <p>- VENTILTRIEB - CIGUENAL BALANCA VÁLVULES Y VÁLVULES</p>
<p>250-400-450-525CC</p> 	<p>250CC</p> 	<p>400-450-525CC</p> 

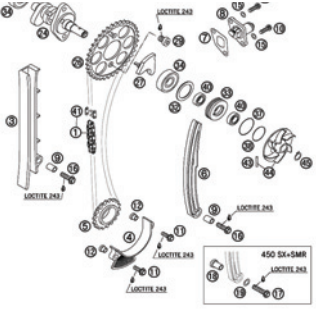
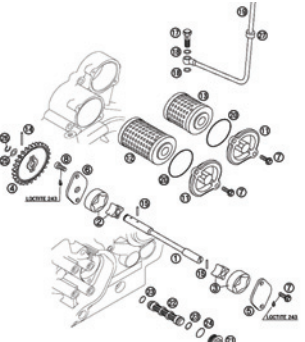
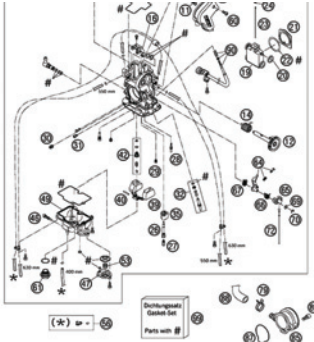
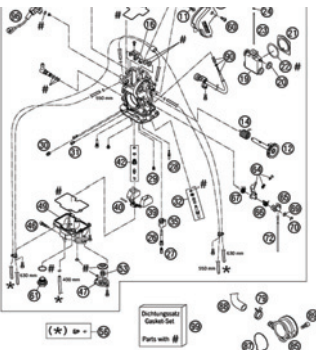
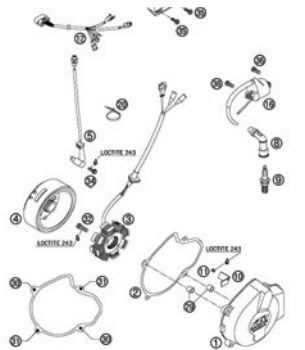
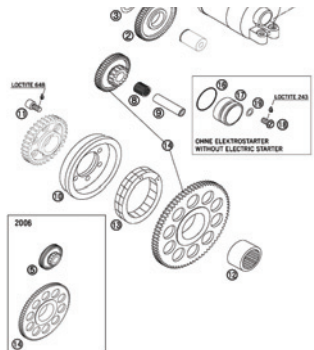
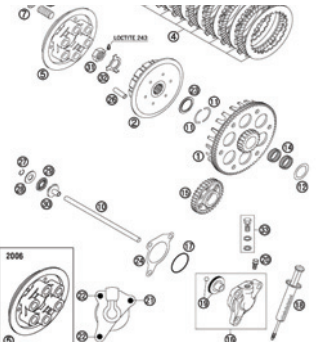
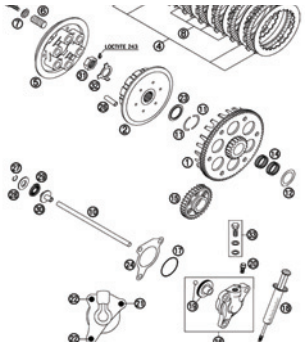
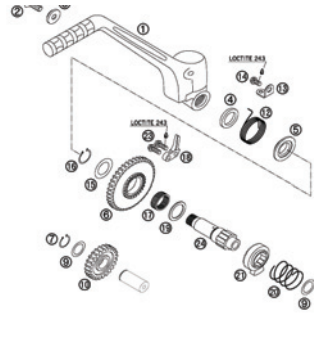
TAV. 10 - CATENA DI DISTRIBUZIONE - TIMING VALVE - CHAÎNE DE DISTRIBUTION	TAV. 11 - SISTEMA DI LUBRIFICAZIONE - LUBRICATING SYSTEM - POMPE À HUILE	TAV. 12 - CARBURATORE FCR-MX37 - CARBURETOR, FCR-MX37 - CARBURATEUR FCR-MX37
250-400-450-525CC 	250-400-450-525CC 	250CC 
TAV. 13 - CARBURATORE FCR-MX39 - CARBURETOR, FCR-MX39 - CARBURATEUR FCR-MX39	TAV. 14 - SISTEMA DI IGNEZIONE 4K3B - IGNITION SYSTEM 4K3B - INSTALLATION ELECTRIQUE 4K3B	TAV. 15 - AVVIAMENTO ELETTRICO - ELECTRIC STARTER - ELECTRIQUE DEMARRAGE
400-450-525CC 	250-400-450-525CC 	250-400-450-525CC 
TAV. 16 - FRIZIONE - CLUTCH - EMBRAYAGE	TAV. 16A - FRIZIONE - CLUTCH - EMBRAYAGE	TAV. 17 - LEVA MESSA IN MOTO - KICKSTARTER - DEMARRAGE
250-400-450-525CC / 2005 250CC / 2006 	400-450-525CC/2006 	250-400-450-525CC 

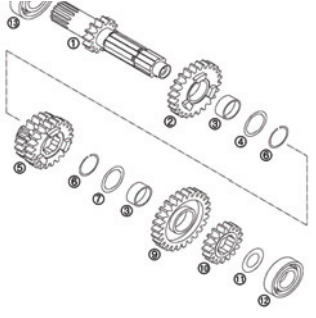
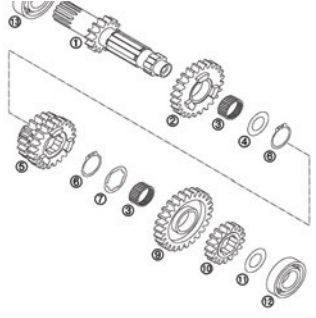
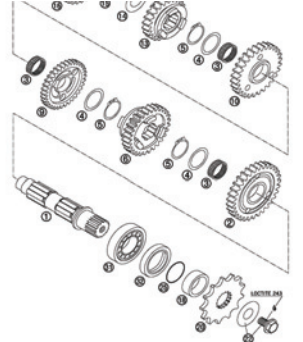
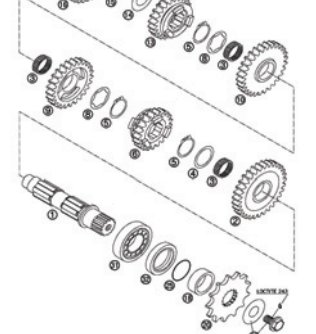
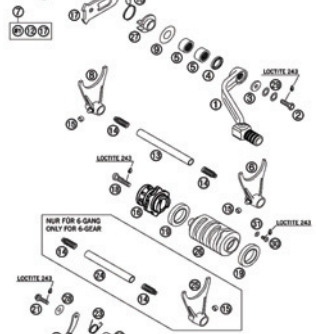
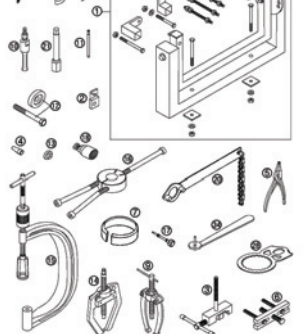
TAV. 18 - TRASMISSIONE PRIMARIA - TRANSMISSION I° - MAIN SHAFT - TRANSMISSION PRIMAIRE	TAV. 19 - TRASMISSIONE PRIMARIA - TRANSMISSION I° - MAIN SHAFT - TRANSMISSION PRIMAIRE	TAV. 20 - TRASMISSIONE SECONDARIA - TRANSMISSION II° - MAIN SHAFT - TRANSMISSION SECONDAIRE
250CC 	400-450-525CC 	250CC 
TAV. 21 - TRASMISSIONE SECONDARIA - TRANSMISSION II° - MAIN SHAFT - TRANSMISSION SECONDAIRE	TAV. 22 - COMANDO CAMBIO - SHIFTING MECHANISM - BOITE A VITESSE	TAV. 23 - ATTREZZATURE - PARTICOLARI NON FIGURATI - SPECIAL TOOLS - SUPPLEMENTARY PARTS LIST - OUTILS - PARTICULIERS PAS MENTIONNES
400-450-525CC 	250-400-450-525CC 	

Pos Loc Pos Ps Pos	Numero Number Número Número Nummer	Nota Note Note Nota Anm.	Descrizione	Description	Désignation	Beschreibung	Descrìption
1	3625210 000	2006	Carter Motore Exc Completo	Engine Case Cpl. W.Tr.Bear	Carter Moteur Exc Complet	Motorgeh. Kpl.M.Getr.Lag.	Carter Motor Exc Completo
2	3625435 000		Carter Motore Exc Completo	Engine Case Cpl. W.Tr.Bear	Carter Moteur Exc Complet	Motorgeh. Kpl.M.Getr.Lag.	Carter Motor Exc Completo
2	3625099 000		Grano Di Riferimento 17 X 14 X 12	Dowel 17 X 14 X 12	Grain 17x14x12	Passhülse 17 X13 X 12	Grano 17x14x12
3	3625087 000		Grano Di Riferimento 9,8 X 7 X 10	Dowel 9,8 X 7 X 10	Grain 9,8x7x10	Passhülse 9,8 X 7 X 10	Grano 9,8x7x10
4	3625235 000		Passatubo Sfiati Carburatore	Hanger For Vent Hose	Passe-Tube Carburateur	Bügel Für Entlüftungsschlauch	Pasa-Tubo Carburador
5	3625004 000		Bullone M6 X 15	Hh Collar Screw M 6x15	Boulon M6x15	Sk.Bundschraube M 6x15 Sw=8	Tornillo M6x5
6	3625176 000		Tappo Olio M12 X 1,5	Oil Drain Plug W.Mag M 12 X 1,5	Bouchon Huile M12x1,5	Ölablasschr.B.Magnet M 12x1,5	Tapa Aceite M12x1,5
7	3625187 000		Guarnizione Tappo Olio Motore	Cu-Seal Ring Din 7603 - 12 X 18 X 1,5	Joint Bouchon Huile Moteur	Cu- Dichtring 12x18x1,5	Junta Tapa Aceite Motor
9	3625062 000		Tappo M12 X 1,5	Plug - M12 X 1,5	Bouchon M12x1,5	Verschl.Schr. M12x1,5	Tapo M12x1,5
10	3625221 000		Grano Di Riferimento 17 X 19 X 12	Dowel 17 X 19 X 12	Grain 17x19x12	Passbüchse 17 X 19 X 12	Grano 17x19x12
11	3625189 000		Molla Di Pressione 25mm 1mm	Pressure Spring L=25mm D=1mm	Ressort Pression 25mm 1mm	Druckfeder L=25mm D=1mm	Muelle Pression 25mm 1mm
12	3625190 000		Valvola Con Pistoncino 10mm	Valve Piston D=10mm	Valve A/Piston 10mm	Ventilkolben D=10mm	Valvola Con Piston 10mm
13	3625436 000	2006	Getto 60 M6x0,75	Jet 60 M6x0,75	Gideur 60 M6x0,75	Düse 60 M6x0,75	Surtidor 60 M6x0,75
17	3625252 000		Tubo Sfiato Motore	Engine Breather Tube	Tube Moteur	Motorentlüftungsschlauch	Tubo Motor
18	3625219 000		Flangia Di Giunzione Tubo Sfiato Motore	Bleeder Flange M12x1,5	Joint Tube Moteur	Entlüft.Stutzen M12x1,5 Sw=13	Junta Tubo Motor
19	3625177 000		Vite Di Centraggio M8 X 23 (400-450-525cc)	Locating Screw M8 L=23 (400-450-525cc)	Vis M8x23 (400-450-525cc)	Fixierschraube M8 L=23 (400-450-525cc)	Tornillo M8x23 (400-450-525cc)
19	3625392 000		Vite Di Centraggio M8 X 34 (250cc)	Locating Screw M8 L=34 (250cc)	Vis M8x34 (250cc)	Fixierschraube M8 L=34 (250cc)	Tornillo M8x34 (250cc)
20	3625178 000		Guarnizione Vite Di Centraggio	Cu-Seal Ring 8 X 14 X 3	Joint Vis	Cu-Dichtring 8 X 14 X 3	Junta Tornillo
21	3625019 000		Rullino 2,5 X 9,8	Needle Roller 2,5 X 9,8	Molette 2,5x9,8	Nadelrolle 2,5x9,8	Rodillo 2,5x9,8
22	3625218 000		Oblo' Livello Olio Motore	Oil Level Glass G 1777 Y	Oblo' Niveau Huile Moteur	Ölschauglas G 1777 Y	Oblo Nivel Aceite Motor
23	2909601 000		Tappo Alimentazione Olio Cr / Exc	Oil Filler Plug	Bouchon Alimentation Huile Cr/Exc	Öleinfüllschraube M 24x3	Tapo Aceite Cr/Exc
24	3625054 000		Anello Or 19 X 3	O-Ring 19 X 3	Or 19x3	O-Ring 19 X 3	Or 19x3
26	3625021 000		Rullino 4,0 X 9,8	Needle Roller 4,0 X 9,8	Molette 4,0x9,8	Nadelrolle 4x9,8	Rodillo 4,0x9,8
29	3625015 000		Guarnizione	Washer	Joint	Unterlegscheibe Din 125 A 5,3	Junta
30	3625076 000		Vite M5x8	Screw M5 X 8	Vis M5x8	Linsenschraube M5x8	Tornillo M5x8
31	3625007 000		Bullone M6 X 8	Screw M6 X 8	Boulon M6x8	Sk.Bundschraube M6x8 Sw=8	Tornillo M6x8

CARTER MOTORE
ENGINE CASE
CARTER
MOTERGEHÄUSE
CARTER

250-400-450-525CC / 2005-2006

TAV.1

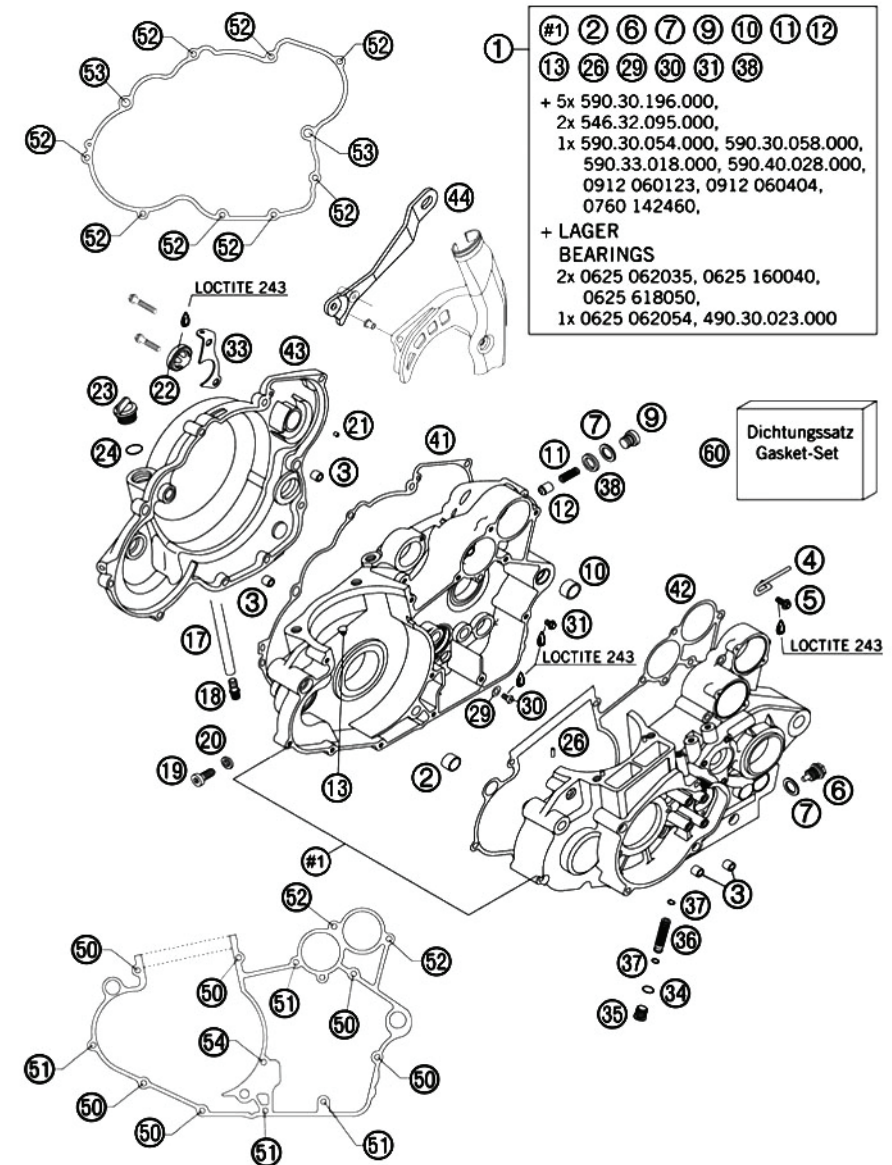

Pos Loc Pos Ps Pos	Numero Number Número Número Nummer	Nota Note Note Nota Anm.	Descrizione	Description	Désignation	Beschreibung	Description
33	3625212 000		Piastrina	Ret. Bracket F. Brake Lever Hub	Plaquette	Haltebl. Für Bremshebelfeder	Placa
34	3625052 000		Anello Or 12 X 2	O-Ring 12 X 2	Or 12x2	O-Ring 12 X 2	Or 12x2
35	3625354 000		Tappo M16 X 1,5	Plug, M16 X 1,5	Bouchon M16x1,5	Verschl.Schr. M16x1,5	Tapa M16x1,5
36	3625355 000		Filtro Olio 11,8mm X 44,5mm	Oil Screen 11,8 X 44,5mm	Filtre Huile 11,8mmx44,5mm	Ölsieb 11,8x44,5mm	Filtro Aceite 11,8mmx44,5mm
37	3625051 000		Anello Or 9 X 1,5	O-Ring 9 X 1,5	Or 9x1,5	O-Ring 9 X 1,5	Or 9x1,5
38	3625036 000		Anello Di Tenuta 12 X 18 X 3	Seal Ring 12 X 18 X 3	Bague 12x18x3	Cu-Dichtring 12x18x3	Anillo 12x18x3
41	3625222 000		Guarnizione Per Coperchio Frizione	Gasket For Clutch Cover	Joint Couvercle Embayage	Kupplungsdeckeldichtubg	Junta Tapa Embrague
42	3625228 000		Guarnizione Carter Motore	Gasket, Engine Case	Joint Protection Moteur	Motorgehäusedichtung Ns92-24	Junta Carter Motor
43	3625211 000		Coperchio Friz. Motore Exc Beta Racing	Clutch Cover, Beta Racing	Couvercle Embayage Moteur Exc Beta Rac.	Kupplungsdeckel	Tapa Embrague Motor Exc Beta Racing
44	3625230 000		Staffa Di Fissaggio Pignone Catena	Chain Dampersheet	Etrier Fixage Pignon De Chaine	Kettendämpfungsblech	Abrazadera Fijacion Pignon Cadena
50	3625011 000		Bullone 6.45 Rs Ch 8	Bolt 6.45	Boulon 6.45 Rs Ch 8	Sk.Bundschaube M6x45 Sw=8	Tornillo 6.45 Rs Ch 8
51	1105485 000		Bullone 6.60 Rs Ch 8	Bolt 6.60	Boulon 6.60 Rs Ch 8	Sk.Bundschaube M6x60 Sw=8	Tornillo 6.60 Rs Ch 8
52	1150300 000		Bullone 6.30 Rs Ch 8	Bolt 6.30	Boulon 6.30 Rs Ch 8	Sk.Bundschaube M6x30 Sw=8	Tornillo 6.30 Rs Ch 8
53	3625009 000		Bullone 6.35 Rs Ch 8	Bolt 6.35	Boulon 6.35 Rs Ch 8	Sk.Bundschaube M6x35 Sw=8	Tornillo 6.35 Rs Ch 8
54	3625013 000		Bullone 6.75 Rs Ch 8	Bolt 6.75	Boulon 6.75 Rs Ch 8	Sk.Bundschaube M6x75 Sw=8	Tornillo 6.75 Rs Ch 8
60	3625236 000		Guarnizioni (Kit Completo)	Gasket Set Cpl	Joints (Jeu Complet)	Dichtungssatz Kpl.	Juntas (Juego Completo)

CARTER MOTORE
ENGINE CASE
CARTER
MOTORGEHÄUSE
CARTER

250-400-450-525CC / 2005-2006

TAV.1

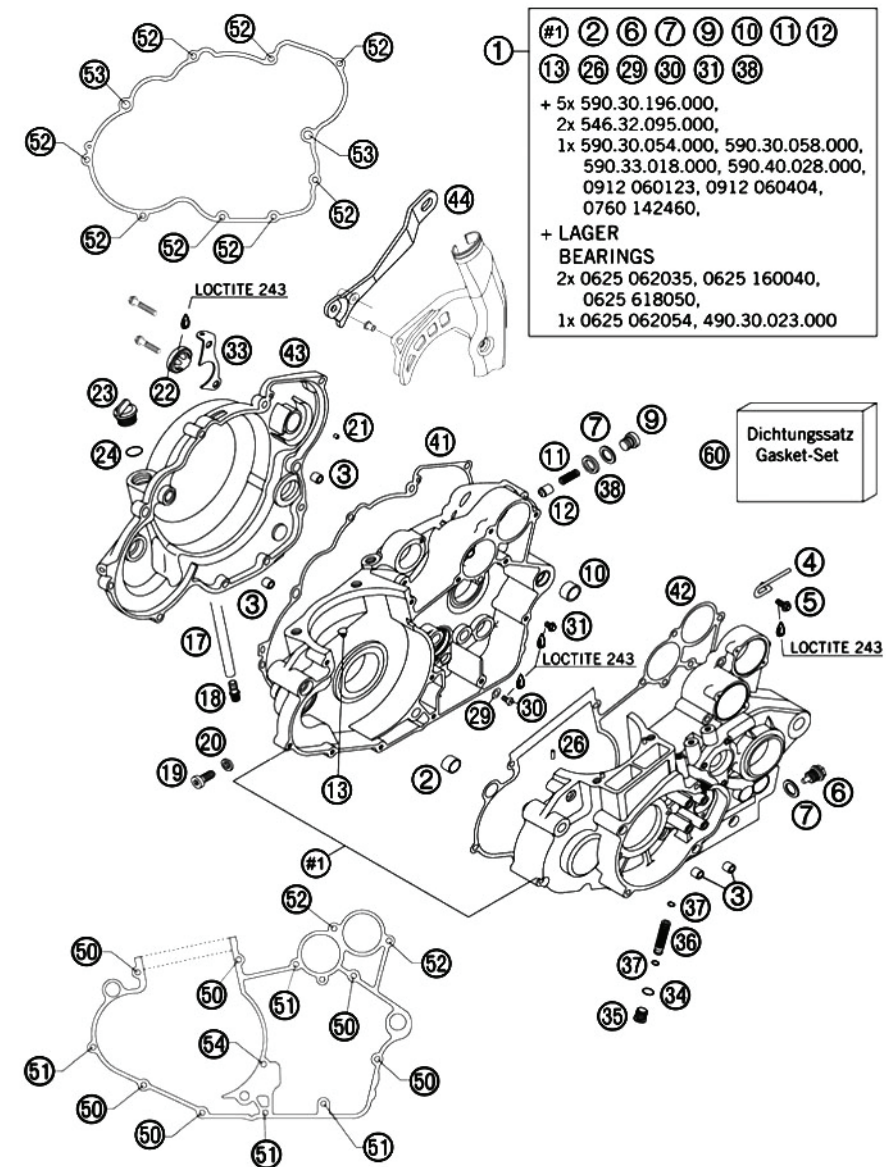

Pos Loc Pos Ps Pos	Numero Number Número Número Nummer	Nota Note Note Nota Anm.	Descrizione	Description	Désignation	Beschreibung	Descrìption
1	3625386 000		Albero Motore Completo Exc 250cc	Crankshaft Cpl. 250cc	Vilebrequin Complet Exc 250cc	Kurbelwelle Kpl. 250cc	Ciguenal Completo Exc 250cc
2	3625216 000		Biella Completa Exc 250/450/525cc	Con.Rod Rep.Set 250/450/525cc	Bielle Complete Exc 250/450/525cc	Pleuel.Rep.Satz 250cc	Biella Completa Exc 250/450/525 Exc
4	3625091 000		Cuscinetto Albero Motore Exc	Roller Bear	Roulement Arbre Moteur Exc	Zylinderr.Lager N°206	Cojinete Arbre Motor Exc
5	3625231 000		Ingranaggio Albero Motore Exc	Drive Gear 32-T EBal-anc.Shaft	Engrange Vilebrequin Exc	Antriebsrad 32-Z Für Agw	Engranaje Ciguenal Exc
6	3625133 000		Rondella Rasamento 30,5x45x0,10	Thrust Washer 30,5x45x0,10	Rondelle 30,5x45x0,10	Passscheibe 30,5x45x0,10	Arandela 30,5x45x0,10
6	3625134 000		Rondella Rasamento 30,7x47x0,15	Thrust Washer 30,7x47x0,15	Rondelle 30,7x47x0,15	Passscheibe 30,7x47x0,15	Arandela 30,7x47x0,15
6	3625135 000		Rondella Rasamento 30,5x45x0,30	Thrust Washer 30,5x45x0,30	Rondelle 30,5x45x0,30	Passscheibe 30,5x45x0,30	Arandela 30,5x45x0,30
7	3625061 000		Chiavetta 3x5x13	Woodruff Key 3x5x13	Clavette 3x5x13	Scheibenfeder 3x5x13	Llave 3x5x13
8	3625072 000		Vite M6x16	Screw M6x16	Vis M6x16	Zyl.Schraube M6x16 8.8	Tornillo M6x16
9	3625046 000		Anello Paraolio 30x47x7	Shaft Seal Ring 30x47x7 Bsl Viton	Joint Spy 30x47x7	Wellendichtr.30x47x7	Junta Aceite 30x47x7
13	3625257 000		Ingranaggio Primario 33 T	Primary Gear 33 T	Engrange Primaire 33t	Primärrad 33-Z	Engranaje Primario 33t
14	3625066 000		Vite M6x10	Screw M6x10	Vis M6x10	Isk.Schraube M6x10.9	Tornillo M6x10
15	3625223 000		Dado Speciale M20x1,5 (Sinistro)	Hh Nur M20x1,5 Ws=27 Left	Ecrout Spec. M20x1,5 (Gauche)	Sk-Mutter M20x1,5	Dado Especial M20x1,5 (Izquierdo)
16	3625002 000		Chiave Speciale 5x6,25	Woodruff Key 5x6,5 Harded	Cle Speciale 5x6,25	Scheibenfeder 5x6,5 Gehärtet	Llave Especial 5x6,25
17	3625044 000		Anello Paraolio 14x24x6	Shaft Seal Ring 14x24x6 B	Joint Spy 14x24x6	Wellendichtring 14x24x6 B	Junta Aceite 14x24x6
18	3625033 000		Anello 25 X 1,2	Girdip 25x1,2	Bague 25x1,2	Sicherungsring 25x1,2	Anillo 25x1,2
20	1325010 000		Dado Spec. Volano Moric Cr 65/85	Nut, Magneto Special	Ecrout Spec. Volant Moric Cr65/86	Bundmutter M12x1 Rechts	Tuerca Espec. Volante Magnético Moric Cr65/85
21	3625017 000		Molla A Tazza	Spring Washer	Ressort	Federscheibe B12	Muelle
33	3625225 000		Spinotto Pistone Motore 250cc	Piston Pin Bolt 20x15,8/12x50	Axe Piston Moteur 250cc	Kolbenbolzen 20x15,8/12x50	Pasador Piston Motor 250cc
34	3625233 000		Anello Ferma Spinotto 20x1,5	Girdip 20x1,5	Bague Axe 20x1,5	Drahtsprengrig C20x1,5	Anillo 20x1,5
40	3625425 000		Pistone Completo I Motore 250cc	Piston I Cpl 250cc	Piston Complet I Moteur 250cc	Kolben I Kpl. 250cc	Piston Completo I Motor 250cc
40	3625426 000		Pistone Completo li Motore 250cc	Piston li Cpl 250cc	Piston Complet li Moteur 250cc	Kolben li Kpl. 250cc	Piston Completo li Motor 250cc
41	3625387 000		Anello Raschia Olio Pistone Motore 250cc	Oil Scraper Ring 75mm	Bague Piston Moteur 250cc	Ölabstreifring 75mm	Anillo Piston Motor 250cc
42	3625388 000		Segmento 75/68 7x1,25 Pist. Motore 250cc	Rectangular Ring 75/68, 7x1,25	Segment 75/68 7x1,25 Piston Moteur 250cc	Rechteckring 75/68,7x1,25	Segmento 75/68 7x1,25 Piston Motor 250cc

**ALBERO MOTORE E PISTONE
CRANKSHAFT - PISTON
VILEBREQUIN ET PISTON
KURBELWELLE - KOLBEN
CIGUENAL Y PYSTON**

250CC / 2005-2006

TAV.2

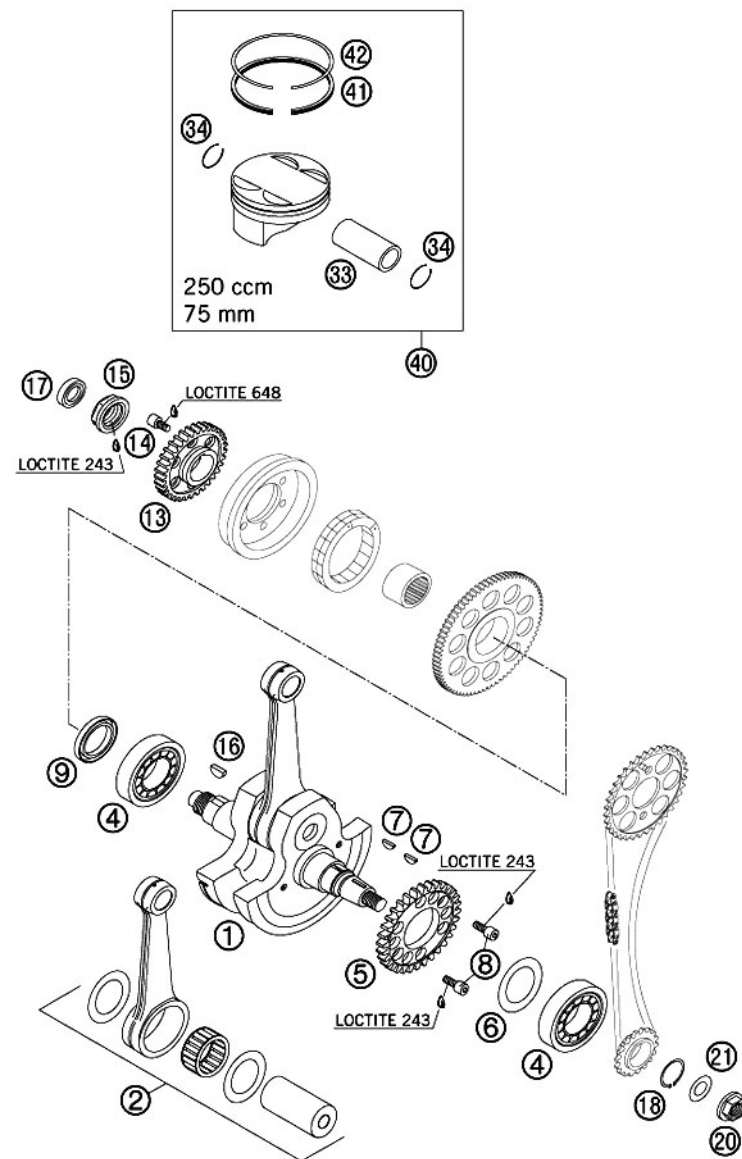

Pos Loc Pos Ps Pos	Numero Number Número Número Nummer	Nota Note Note Nota Anm.	Descrizione	Description	Désignation	Beschreibung	Descrìption
1	3625380 000		Albero Motore Completo Exc 400cc	Crankshaft Cpl. 400cc	Vilebrequin Complet Exc 400cc	Kurbelwelle Kpl. 400cc	Ciguenal Completo Exc 400cc
1	3625438 000	2006	Albero Motore Completo Exc 400cc	Crankshaft Cpl. 400cc	Vilebrequin Complet Exc 400cc	Kurbelwelle Kpl. 400cc	Ciguenal Completo Exc 400cc
2	3625379 000		Biella Completa Exc 400cc	Con.Rod Rep.Set 400cc	Bielle Complete Exc 400cc	Pleuel.Rep.Satz 400cc	Bielle Completa Exc 400cc
4	3625091 000		Cuscinetto Albero Motore Exc	Cyl.Roller Bear	Roulement Arbre Moteur Exc	Zylinder.Lager Nj206	Cojinete Arbre Motor Exc
5	3625231 000		Ingranaggio Albero Motore Exc	Drive Gear 32-T E-Bal-anc.Shaft	Engranaqe Vilebrequin Exc	Antriebsrad 32-Z Für Agw	Engranaje Ciguenal Exc
6	3625133 000		Rondella Rasamento 30,5x45x0,10	Thrust Washer 30,5x45x0,10	Rondelle 30,5x45x0,10	Passscheibe 30,5x45x0,10	Arandela 30,5x45x0,10
6	3625134 000		Rondella Rasamento 30,7x47x0,15	Thrust Washer 30,7x47x0,15	Rondelle 30,7x47x0,15	Passscheibe 30,7x47x0,15	Arandela 30,7x47x0,15
6	3625135 000		Rondella Rasamento 30,5x45x0,30	Thrust Washer 30,5x45x0,30	Rondelle 30,5x45x0,30	Passscheibe 30,5x45x0,30	Arandela 30,5x45x0,30
7	3625061 000		Chiavetta 3x5x13	Woodruff Key 3x5x13	Clavette 3x5x13	Scheibenfeder 3x5x13	Llave 3x5x13
8	3625072 000		Vite M6x16	Screw M6x16	Vis M6x16	Zyl.Schraube M6x16 8.8	Tornillo M6x16
9	3625046 000		Anello Paraolio 30x47x7	Shaft Seal Ring 30x47x7 Bsl Viton	Joint Spy 30x47x7	Wellendichtr.30x47x7	Junta Aceite 30x47x7
13	3625257 000		Ingranaggio Primario 33 T	Primary Gear 33 T	Engranaqe Primaire 33t	Primärrad 33-Z	Engranaje Primario 33t
14	3625066 000		Vite M6x10	Screw M6x10	Vis M6x10	Isk.Schraube M6x10.9	Tornillo M6x10
15	3625223 000		Dado Speciale M20x1,5 (Sinistro)	Hh Nur M20x1,5 Ws=27 Left	Ecrou Spec. M20x1,5 (Gauche)	Sk-Mutter M20x1,5	Dado Especial M20x1,5 (Izquierdo)
16	3625002 000		Chiave Speciale 5x6,25	Woodruff Key 5x6,5 Harded	Cle Speciale 5x6,25	Scheibenfeder 5x6,5 Gehärtet	Llave Especial 5x6,25
17	3625044 000		Anello Paraolio 14x24x6	Shaft Seal Ring 14x24x6 B	Joint Spy 14x24x6	Wellendichtring 14x24x6 B	Junta Aceite 14x24x6
18	3625033 000		Anello 25 X 1,2	Circlip 25x1,2	Bague 25x1,2	Sicherungsring 25x1,2	Anillo 25x1,2
20	1325010 000		Dado Spec. Volano Moric Cr 65/85	Nut, Magneto Special	Ecrou Spec. Volant Moric Cr65/86	Bundmutter M12x1 Rechts	Tuerca Espec. Volante Magnético Moric Cr65/85
21	3625017 000		Molla A Tazza	Spring Washer	Ressort	Federscheibe B12	Muelle
33	3625225 000		Spinotto Pistone Motore 250cc	Piston Pin Bolt 20x15,8/12x50	Axe Piston Moteur 250cc	Kolbenbolzen 20x15,8/12x50	Pasador Piston Motor 250cc
34	3625233 000		Anello Ferma Spinotto 20x1,5	Circlip 20x1,5	Bague Axe 20x1,5	Drahtsprengring C20x1,5	Anillo 20x1,5
40	3625423 000		Pistone Completo I Motore 400cc	Piston I Cpl 400cc	Piston Complet I Moteur 400cc	Kolben I Kpl. 89mm 400cc	Piston Completo I Motor 400cc
40	3625424 000		Pistone Completo li Motore 400cc	Piston li Cpl 400cc	Piston Complet li Moteur 400cc	Kolben li Kpl. 89mm 400cc	Piston Motor Completo li Motor 400cc
41	3625381 000		Anello Raschia Olio Pist. Mot.400/450cc	Oil Scraper Ring 89/81,5x3	Bague Piston Moteur 400/450cc	Ölabstreifring 89/81,5x3	Anillo Piston Motor 400/452cc
42	3625172 000		Segmento 89mm Pist. Motore 400cc	Rectangular Ring 89mm	Segment 89mm Piston Moteur 400cc	Rechteckring 89mm	Segmento 89mm Piston Motor 400cc

**ALBERO MOTORE E PISTONE
CRANKSHAFT - PISTON
VILEBREQUIN ET PISTON
KURBELWELLE - KOLBEN
CIGUENAL Y PYSTON**

400CC / 2005-2006

TAV.3

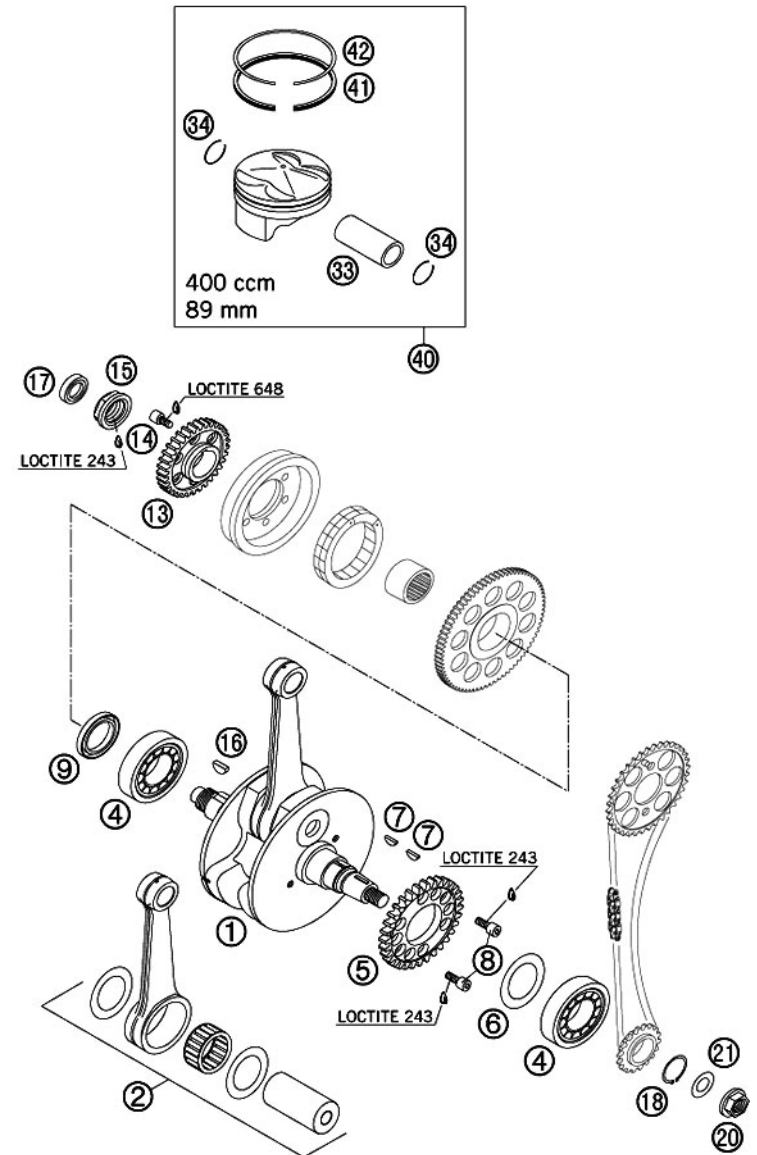

Pos Loc Pos Ps Pos	Numero Number Número Número Nummer	Nota Note Note Nota Anm.	Descrizione	Description	Désignation	Beschreibung	Descrìption
1	3625217 000		Albero Motore Completo Exc 450/525cc	Crankshaft Cpl. 450/525cc	Vilebrequin Compl. Exc 450/525cc	Kurbelwelle Kpl. 450/525cc	Ciguenal Completo Exc 450/525cc
1	3625439 000	2006	Albero Motore Completo Exc 450/525cc	Crankshaft Cpl. 450/525cc	Vilebrequin Compl. Exc 450/525cc	Kurbelwelle Kpl. 450/525cc	Ciguenal Completo Exc 450/525cc
2	3625216 000		Biella Completa Exc 250/450/525cc	Con.Rod Rep.Set 250/450/525cc	Bielle Complete Exc 250/450/525cc	Pleuel.Rep.Satz 450/525cc	Biella Completa Exc 250/450/525cc
4	3625091 000		Cuscinetto Albero Motore Exc	Cyl.Roller Bear	Roulement Arbre Moteur Exc	Zylinderr.Lager Nj206	Cojinete Arbre Motor Exc
5	3625231 000		Ingranaggio Albero Motore Exc	Drive Gear 32-T.FE-Bal-anc.Shaft	Engranage Vilebrequin Exc	Antriebsrad 32-Z Für Agw	Engranaje Ciguenal Exc
6	3625133 000		Rondella Rasamento 30,5x45x0,10	Thrust Washer 30,5x45x0,10	Rondelle 30,5x45x0,10	Passscheibe 30,5x45x0,10	Arandela 30,5x45x0,10
6	3625134 000		Rondella Rasamento 30,7x47x0,15	Thrust Washer 30,7x47x0,15	Rondelle 30,7x47x0,15	Passscheibe 30,7x47x0,15	Arandela 30,7x47x0,15
6	3625135 000		Rondella Rasamento 30,5x45x0,30	Thrust Washer 30,5x45x0,30	Rondelle 30,5x45x0,30	Passscheibe 30,5x45x0,30	Arandela 30,5x45x0,30
7	3625061 000		Chiavetta 3x5x13	Woodruff Key 3x5x13	Clavette 3x5x13	Scheibenfeder 3x5x13	Llave 3x5x13
8	3625072 000		Vite M6x16	Screw M6x16	Vis M6x16	Zyl.Schraube M6x16 8.8	Tornillo M6x16
9	3625046 000		Anello Paraolio 30x47x7	Shaft Seal Ring 30x47x7 Bsl Viton	Joint Spy 30x47x7	Wellendichtr.30x47x7	Junta Aceite 30x47x7
13	3625257 000		Ingranaggio Primario 33 T	Primary Gear 33 T	Engranage Primaire 33t	Primärrad 33-Z	Engranaje Primario 33t
14	3625066 000		Vite M6x10	Screw M6x10	Vis M6x10	Isk.Schraube M6x10.9	Tornillo M6x10
15	3625223 000		Dado Speciale M20x1,5 (Sinistro)	Hh Nur M20x1,5 Ws=27 Left	Ecrou Spec. M20x1,5 (Gauche)	Sk-Mutter M20x1,5	Dado Especial M20x1,5 (Izquierdo)
16	3625002 000		Chiave Speciale 5x6,25	Woodruff Key 5x6,5 Harded	Cle Speciale 5x6,25	Scheibenfeder 5x6,5 Gehärtet	Llave Especial 5x6,25
17	3625044 000		Anello Paraolio 14x24x6	Shaft Seal Ring 14x24x6 B	Joint Spy 14x24x6	Wellendichtring 14x24x6 B	Junta Aceite 14x24x6
18	3625033 000		Anello 25 X 1,2	Circlip 25x1,2	Bague 25x1,2	Sicherungsring 25x1,2	Anillo 25x1,2
20	1325010 000		Dado Spec. Volano Moric Cr 65/85	Nut, Magneto Special	Ecrou Spec. Volant Moric Cr65/86	Bundmutter M12x1 Rechts	Tuerca Espec. Volante Magneto Moric Cr65/85
21	3625017 000		Molla A Tazza	Spring Washer	Ressort	Federscheibe B12	Muelle
33	3625225 000		Spinotto Pistone Motore 250cc	Piston Pin Bolt 20x15,8/12x50	Axe Piston Moteur 250cc	Kolbenbolzen 20x15,8/12x50	Pasador Piston Motor 250cc
34	3625233 000		Anello Ferma Spinotto 20x1,5	Circlip 20x1,5	Bague Axe 20x1,5	Drahtsprengrig C20x1,5	Anillo 20x1,5
40	3625421 000		Pistone Completo I Motore 450cc	Piston I Cpl 450cc	Piston Complet I Moteur 450cc	Kolben I Kpl. 89mm Gr.1 450cc	Piston Completo I Motor 450cc
40	3625422 000		Pistone Completo li Motore 450cc	Piston li Cpl 450cc	Piston Complet li Moteur 450cc	Kolben li Kpl. 89mm Gr.2 450cc	Piston Completo li Motor 450cc
41	3625381 000		Anello Raschia Olio Pist. Mot.400/450cc	Oil Scraper Ring 89/81,5x3	Bague Piston Moteur 400/450cc	Ölabstreifring 89/81,5x3	Anillo Piston Motor 400/452cc
42	3625172 000		Segmento 89mm Pist. Motore 400cc	Rectangular Ring 89mm	Segment 89mm Piston Moteur 400cc	Rechteckring 89mm	Segmento 89mm Piston Motor 400cc

**ALBERO MOTORE E PISTONE
CRANKSHAFT - PISTON
VILEBREQUIN ET PISTON
KURBELWELLE - KOLBEN
CIGUENAL Y PYSTON**

450-525CC / 2005-2006

TAV.4

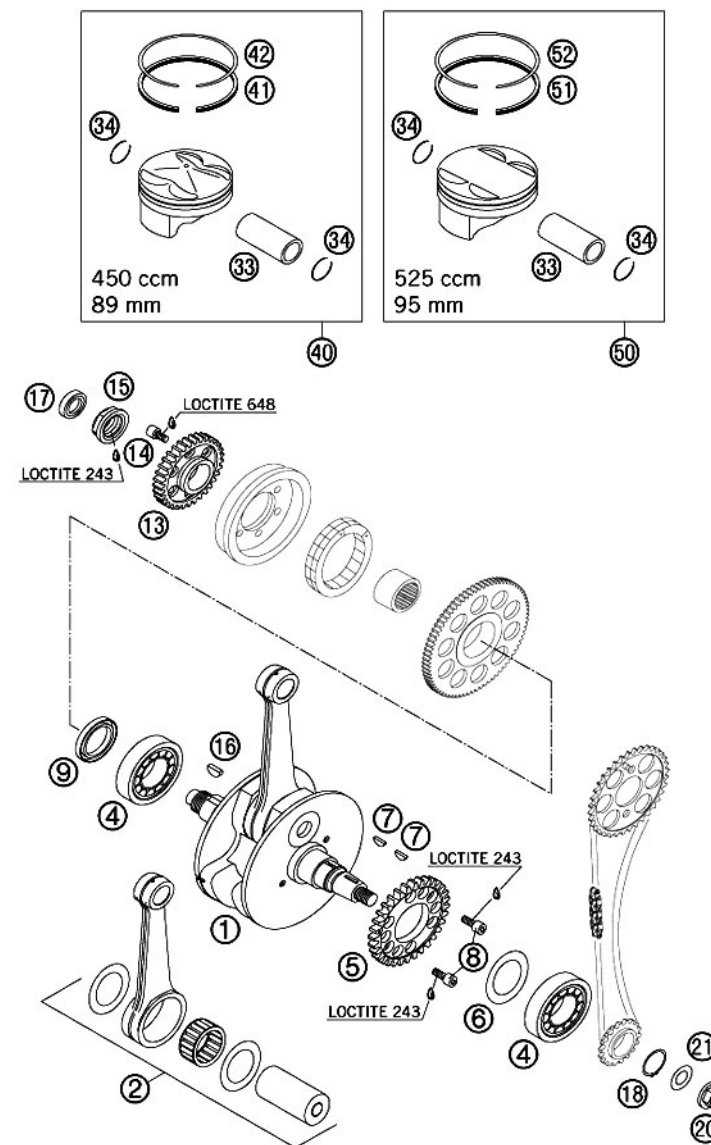

Pos Loc Pos Ps Pos	Numero Number Numéro Nùmero Nummer	Nota Note Note Nota Anm.	Descrizione	Description	Désignation	Beschreibung	Descripción
50	3625417 000		Pistone Completo I Motore 525cc	Piston I Cpl 525cc	Piston Complet I Moteur 525cc	Kolben I Kpl. 95mm Gr.1 525cc	Piston Completo I Motor 525cc
50	3625418 000		Pistone Completo li Motore 525cc	Piston li Cpl 525cc	Piston Complet li Moteur 525cc	Kolben li Kpl. 95mm Gr.2 525cc	Piston Completo li Motor 525cc
51	3625179 000		Anello Raschia Olio Pist. Motore 525cc	Oil Scraper Ring 95mm	Bague Piston Moteur 525cc	Ölabstreifring 95	Anillo Piston Motor 525cc
52	3625224 000		Segmento 95/87,2x1,25 Pist. Motore 525cc	Rectangular Ring 95/87,2x1,25	Segment 95/87,2x1,25 Piston Moteur 525cc	Rechteckring 95/87,2x1,25	Segmento 95/87,2x1,25 Piston Motor 525cc

**ALBERO MOTORE E PISTONE
CRANKSHAFT - PISTON
VILEBREQUIN ET PISTON
KURBELWELLE - KOLBEN
CIGUENAL Y PYSTON**

450-525CC / 2005-2006

TAV.4

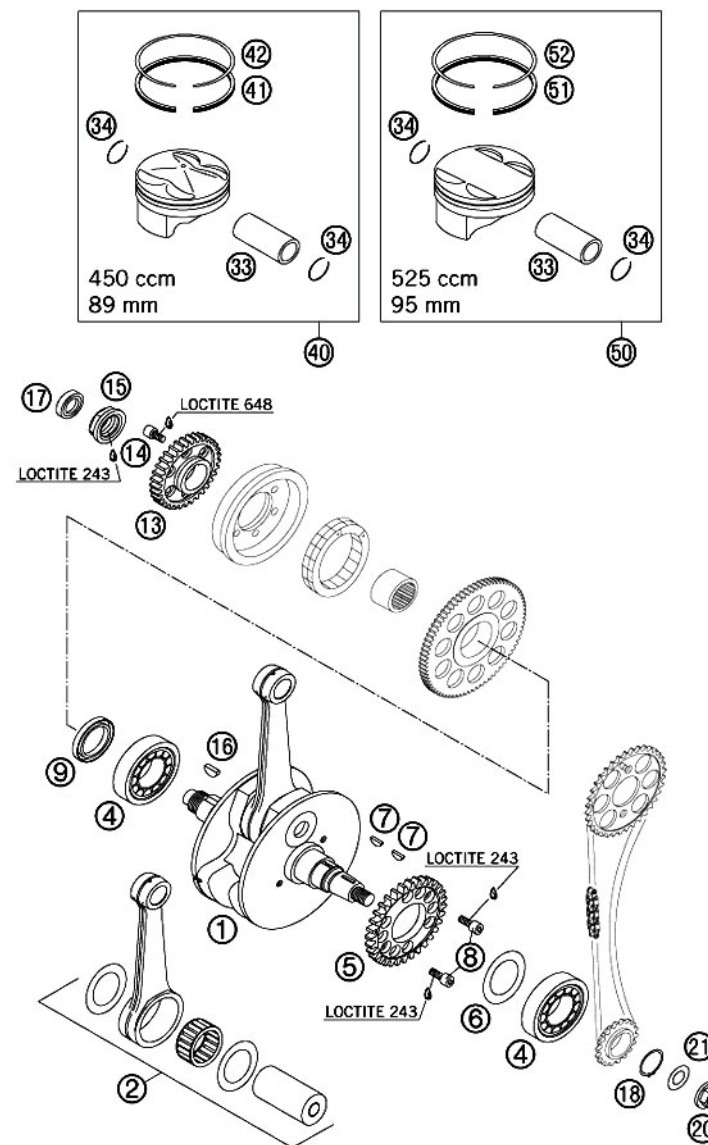

Pos Loc Pos Ps Pos	Numero Number Numéro Número Nummer	Nota Note Note Nota Anm.	Descrizione	Description	Désignation	Beschreibung	Descripción
1	3625390 000		Albero Bilanciam. Con Ingr.250cc	Balanver Shaft W/Gear-wheel 250cc	Arbre Avec Engranage 250cc	Agw Kpl.Mit Zahnrad 250cc	Ciguenal Balance Con Engranaje 250cc
2	3625232 000		Albero Bilanciamento Completo 400-450-525cc	Balanver Shaft Cpl. 400/450/525cc	Arbre Complet 400/450/525cc	Ausgleichswelle Kpl. 400/450/525cc	Ciguenal Completo 400/450/525cc
4	3625041 000		Cuscinetto Albero Bilanciamento Exc	Cyl.Roller Bear	Roulement Exc	Rillenkugellager Tm 16004 C3	Cojinete Arbre Exc
6	3625044 000		Anello Paraolio 14x24x6	Shaft Seal Ring 14x24x6 B	Joint Spy 14x24x6	Wellendichtring 14x24x6 B	Junta Aceite 14x24x6

**ALBERO BILANCIAMENTO
BALANCER SHAFT
VILEBREQUIN BALANCER
AUSGLEICHSWELLE
CIGUENAL BALANCA**

250-400-450-525CC / 2005-2006

TAV.5

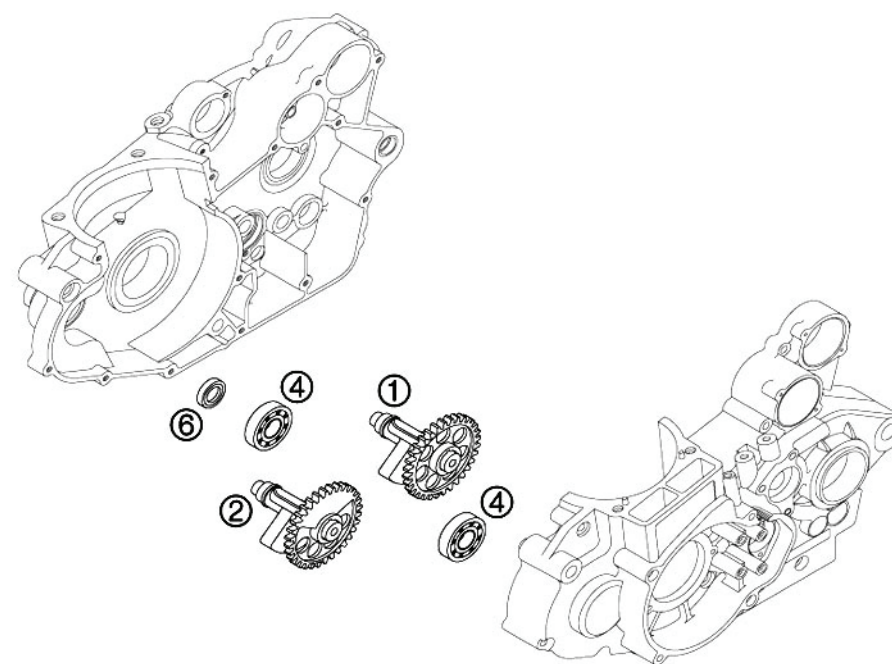

Pos Loc Pos Ps Pos	Numero Number Numéro Número Nummer	Nota Note Note Nota Anm.	Descrizione	Description	Désignation	Beschreibung	Description
1	3625215 000		Cilindro 95mm Motore 525cc	Cylinder 95mm	Cylindre 95mm Moteur 525cc	Zylinder 95mm 525cc	Cilindro 95mm Motor 525cc
1	3625378 000		Cilindro 89mm Motore 400/450cc	Cylinder 400/450mm	Cylindre 89mm Moteur 400/450cc	Zylinder 89mm 400/450cc	Cilindro 89mm Motor 400/450cc
1	3625385 000		Cilindro 75mm Motore 250cc	Cylinder 75mm	Cylindre 75mm Moteur 250cc	Zylinder 75mm 250cc	Cilindro 75mm Motor 250cc
2	3625226 000		Guarnizione Base Cil.0,5mm 250/400/525cc	Cylinder Base Gasket 0,5mm 250/400/525cc	Joint Base Cylindre 0,5mm 250/400/525cc	Zylinderfussdichtung 0,5mm 250/400/525cc	Junta Base Cilindro 0,5mm 250/400/525cc
2	3625372 000		Guarnizione Base Cil.0,8mm 450cc	Cylinder Base Gasket 0,8mm 450cc	Joint Base Cylindre 0,8mm 450cc	Zylinderfussdichtung 0,8mm 450cc	Junta Base Cilindro 0,8mm 450cc
3	3625220 000		Grano Di Riferimento 6 X 8 X 11,5	Dowel 6 X 8 X 11,5	Grain 6x8x11,5	Passhülse 6x8x11,5	Grano 6x8x11,5
4	3625010 000		Bullone 6.40 Rs Ch 8	Collar Screw M6x40 Ws 8	Boulon 6.40 Rs Ch 8	Sk.Bundschaube M6x40 Sw=8	Tornillo 6.40 Rs Ch 8
5	3625011 000		Bullone 6.45 Rs Ch 8	Bolt 6.45	Boulon 6.45 Rs Ch 8	Sk.Bundschaube M6x45 Sw=8	Tornillo 6.45 Rs Ch 8
7	3625021 000		Rullino 4,0 X 9,8	Needle Roller 4,0 X 9,8	Molette 4,0x9,8	Nadelrolle 4x9,8	Rodillo 4,0x9,8
8	3625034 000		Guarnizione 6x10x1	Cu-Seal Ring 6x10x1	Joint 6x10x1	Cu-Dichtring 6x10x1	Junta 6x10x1
9	3625008 000		Bullone 6.10 Rs Ch 8	Collar Screw M6x10 Ws 8	Boulon 6.10 Rs Ch 8	Sk.Bundschaube M6x10 Sw=8	Tornillo 6.10 Rs Ch 8

CILINDRO
CYLINDER
CYLINDRE
ZYLINDER
CILINDRO

250-400-450-525CC / 2005-2006

TAV.6

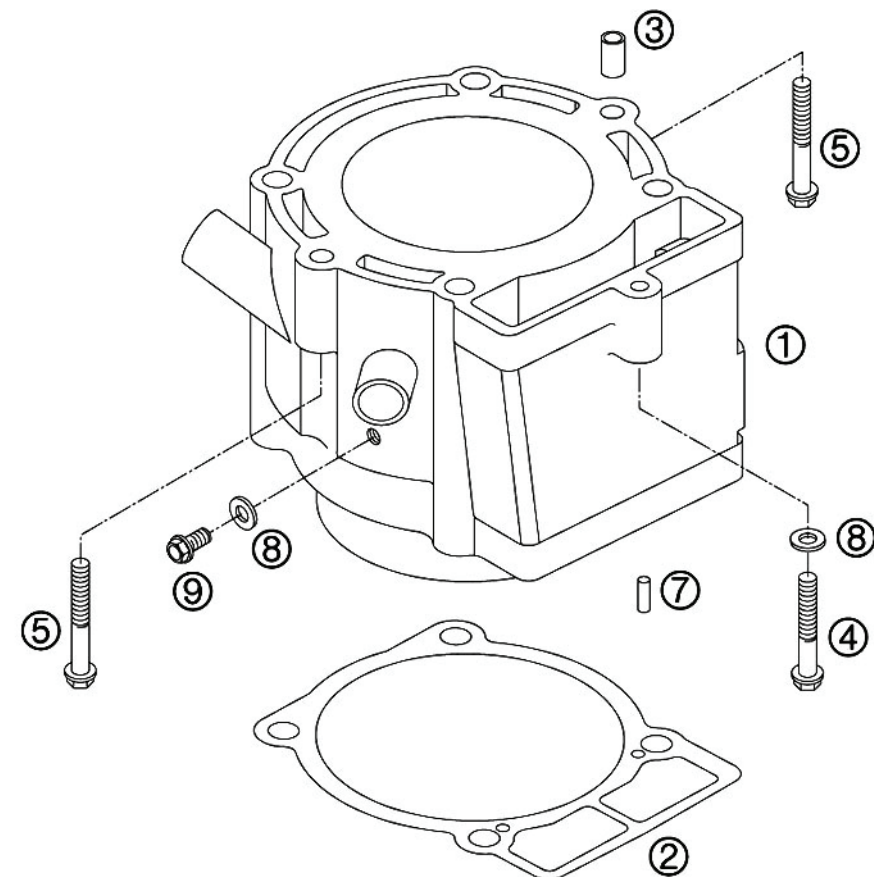

Pos Loc Pos Ps Pos	Numero Number Numéro Número Nummer	Nota Note Note Nota Anm.	Descrizione	Description	Désignation	Beschreibung	Descrìption
1	3625326 000		Testa (Completa) Motore 400/450/525cc	Cylinder Head Cpl. 400/450/525cc	Tete (Complete) Moteur 400/450/525cc	Zylinderk.Kpl 400/450/525cc	Culata(Completa) Motor 400/450/525cc
1	3625408 000		Testa (Completa) Motore 250cc	Cylinder Head Cpl. 250cc	Tete (Complete) Moteur 250cc	Zylinderk.Kpl 250cc	Culata (Completa) Motor 250cc
2	3625227 000		Guarnizione Cilindro/Testa 95,3mm 525cc	Cylinder Head Gasket 95,3mm 525cc	Joint Cylindre/Tete 95,3mm 525cc	Zylinderkopfdichtung 95,3mm 525cc	Junta Cilindro/Culata 95,3mm 525cc
2	3625382 000		Guarnizione Cil/Testa 89,3mm 400/450cc	Cylinder Head Gasket 89,3mm 400/450cc	Joint Cylindre/Tete 89,3mm 400/450cc	Zylinderkopfdichtung 89,3mm 400-450cc	Junta Cilindro/Culata 400/450cc
2	3625389 000		Guarnizione Cil./Testa 75mm 250cc	Cylinder Head Gasket 75mm 250cc	Joint Cylindre/Tete 75mm 250cc	Zylinderkopfdichtung 75mm 250cc	Junta Cilindro/Culata 75mm 250cc
3	3625182 000	2006	Coperchio Valvole	Valve Cover	Couverde Valve	Ventildeckel Hinten	Tapa Valvulas
3	3625456 000		Coperchio Valvole	Valve Cover	Couverde Valve	Ventildeckel Hinten	Tapa Valvulas
4	3625183 000		Guarnizione Coperchio Posteriore Valvole	Valve Cover Gasket	Joint Couverde Arriere Valves	Ventildeckeldichtung	Junta Tapa Trasera Valvulas
5	3625012 000		Bullone 6.55 Rs Ch 8 10.9	Collar Screw M6x55 Ws 8 (10.9)	Boulon 6.55 Rs Ch 8 10.9	Sk.Bundschaube M6x55 Sw=8 10.9	Tornillo 6.55 Rs Ch 8 10.9
6	3625011 000		Bullone 6.45 Rs Ch 8	Bolt 6.45	Boulon 6.45 Rs Ch 8	Sk.Bundschaube M6x45 Sw=8	Tornillo 6.45 Rs Ch 8
7	3625013 000		Bullone 6.75 Rs Ch 8	Bolt 6.75	Boulon 6.75 Rs Ch 8	Sk.Bundschaube M6x75 Sw=8	Tornillo 6.75 Rs Ch 8
8	1150300 000		Bullone 6.30 Rs Ch 8	Bolt 6.30	Boulon 6.30 Rs Ch 8	Sk.Bundschaube M6x30 Sw=8	Tornillo 6.30 Rs Ch 8
9	1105535 000		Bullone 6.50 Rs Ch 8	Bolt 6.50	Boulon 6.50 Rs Ch 8	Sk.Bundschaube M6x50 Sw=8	Tornillo 6.50 Rs Ch 8
10	3625327 000	2006	Guida Valvole Aspirazione	Valve Guide Intake	Guide Valves Aspiration	Ventilführung Einlass	Guia Valvulas Aspiracion
10	3625457 000		Guida Valvole Aspirazione	Valve Guide Intake	Guide Valves Aspiration	Ventilführung Einlass	Guia Valvulas Aspiracion
11	3625328 000		Guida Valvole Scarico	Valve Guide Exhaust	Guide Valves	Ventilführung Auslass	Guia Valvulas
12	2213205 000		Manicotto Carb. Mot. 250/400/450/525 Exc	Intake Boot	Douille Carb. Moteur 250/400/450/525 Exc	Gummimuffe	Manguito Carb. Motor 250/400/450/525 Exc
12	3625459 000	2006	Manicotto Carb. Mot. 250/400/450/525 Exc	Intake Boot	Douille Carb. Moteur 250/400/450/525 Exc	Gummimuffe	Manguito Carb. Motor 250/400/450/525 Exc
13	1514272 000		Fascetta Rac.Aspiraz.250/400/450/525 Exc	Clamp	Tige Rac. Asp. 250/400/450/525 Exc	Schelle D=56mm B=9mm M4x25	Brida Enlace Aspiracion 250/400/450/525 Exc
15	3625375 000		Bocchettone Di Scarico 400/450/525cc	Exhaust Flange Cpl. 400/450/525cc	Joint D'echappement 400/450/525cc	Auspufflansch Kpl. 400/450/525cc	Tube Escape 400/450/525cc
15	3625412 000		Bocchettone Di Scarico 250cc	Exhaust Flange Cpl. 250cc	Tube D'echappement 250cc	Auspufflansch Kpl. 250cc	Tube Escape 250cc
16	3625334 000		Guarnizione Bocchettone Scarico	Gasket Exhaust Flange	Joint Goulotte Vidange	Dichtung Auspufflansch	Junta Tubo
17	1149070 000		Bullone 6.20 Rs Ch 8	Bolt 6.20	Boulon 6.20 Rs Ch 8	Sk.Bundschaube M6x20 Sw=8	Tornillo 6.20 Rs Ch 8
18	3625034 000		Guarnizione 6x10x1	Cu-Seal Ring 6x10x1	Joint 6x10x1	Cu-Dichtring 6x10x1	Junta 6x10x1
19	1148025 000		Bullone 6.16 Rs Ch 8	Bolt 6.16	Boulon 6.16 Rs Ch 8	Sk.Bundschaube M6x16 Sw=8	Tornillo 6.16 Rs Ch 8

TESTA
CYLINDER HEAD
CULASSE
ZYLINDERKOPF
CULATA

250-400-450-525CC / 2005-2006

TAV.7

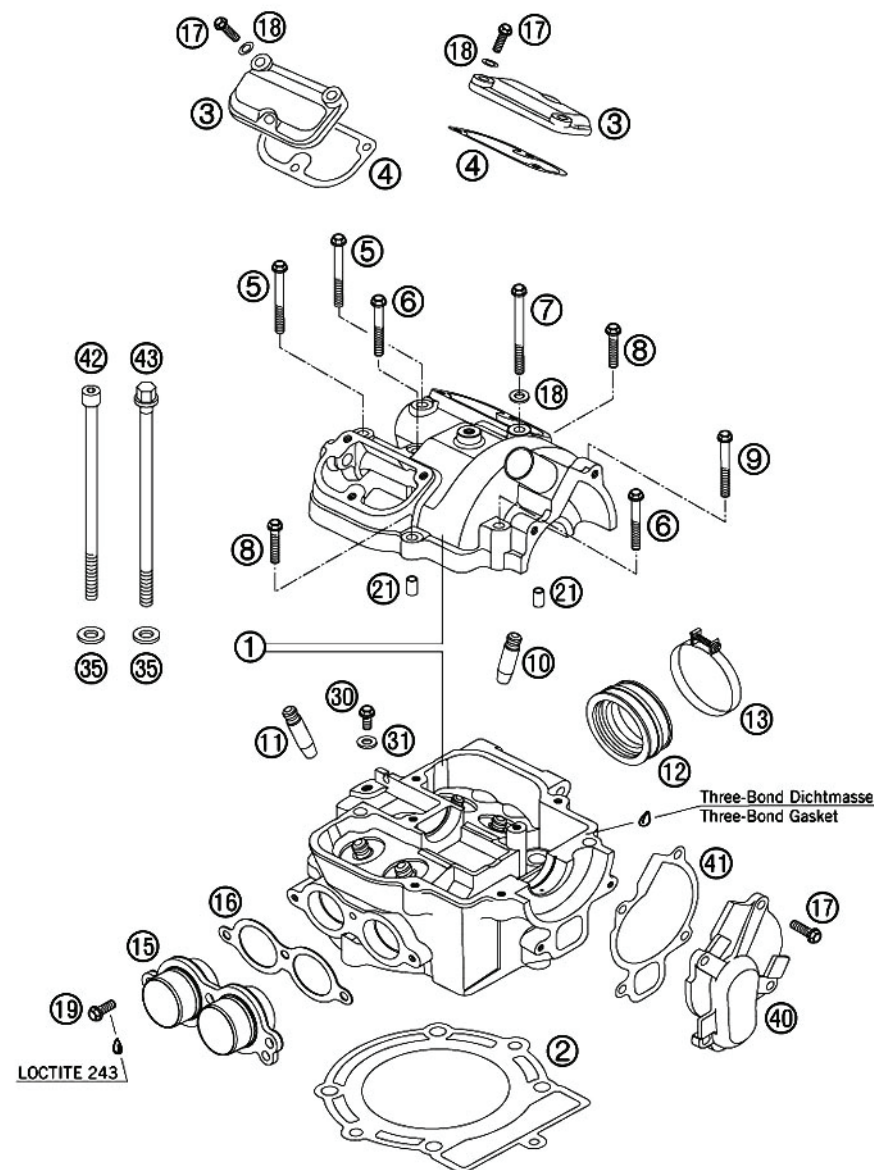

Pos Loc Pos Ps Pos	Numero Number Numéro Nùmero Nummer	Nota Note Note Nota Anm.	Descrizione	Description	Désignation	Beschreibung	Description
21	3625220 000		Grano Di Riferimento 6 X 8 X 11,5	Dowel 6 X 8 X 11,5	Grain 6x8x11,5	Passhülse 6x8x11,5	Grano 6x8x11,5
30	3625316 000		Bullone Sfiato 6.10 Completo	Vent Screw M6x10 Cpl.	Boulon 6.10 Complet	Entlüftungsschraube M6x10 Kpl.	Tornillo 6.10 Completo
31	3625184 000		Guarnizione Bullone Scarico 6x10x2	Cu-Seal Ring 6x10x2	Joint Boulon 6x10x2	Cu-Dichtring 6x10x2	Junta Tornillo 6x10x2
35	3625348 000		Rondella 10,8x18,8x1,5	Washer 10,8x18,8x1,5	Rondelle 10,8x18,8x1,5	Scheibe 10,8x18,8x1,5	Arandela 10,8x18,8x1,5
40	3625308 000		Coperchio Pompa Acqua	Water Pump Cover	Couvercle Pompe Eau	Wasserpumpendeckel	Tapa Bomba Agua
41	3625309 000		Guarnizione Coperchio Pompa Acqua 0,8mm	Water Pump Cover Gasket 0,8mm	Joint Couvercle Pompe A Eau 0,8mm	Wasserpumpendeckel Dichtung 0,8mm	Junta Tapa Bomba Agua 0,8mm
42	3625067 000		Bullone Fis. Testa 250cc 10.150(10.9)	Ah Screw M10x150 10.9, 250cc	Boulon Fix. Culasse 250cc 10.150	Isk-Schr. M10x150 10.9 250cc	Tornillo Fijacion Culata 250cc 10.150
43	3625345 000		Bullone Fis. Testa 400/450/525cc 10.158	Screw M10x158 Ws.13, 400/450/525cc	Boulon Fix Culasse 400/450/525cc 10.158	Isk-Schr. M10x150 10.9 400/450/525cc	Tornillo Fij. Culata 400/450/525cc 10.158

TESTA
CYLINDER HEAD
CULASSE
ZYLINDERKOPF
CULATA

250-400-450-525CC / 2005-2006

TAV.7

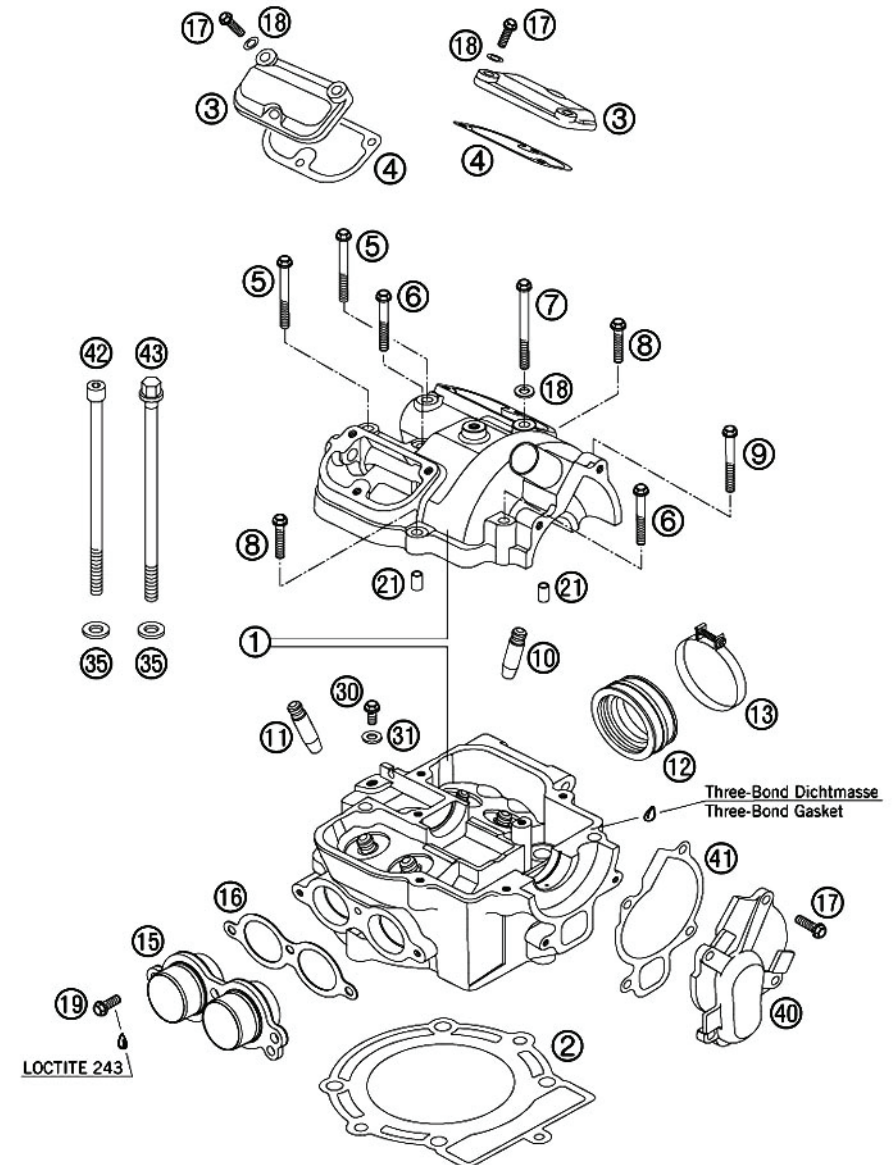

Pos Loc Pos Ps Pos	Numero Number Número Número Nummer	Nota Note Note Nota Anm.	Descrizione	Description	Désignation	Beschreibung	Descripción
1	3625410 000		Valvola Aspirazione 28mm 250cc	Intake Valve 28mm 250cc	Valve Aspiration 28mm 250cc	Einlassventil 28mm 250cc	Valvula Aspiracion 28mm 250cc
2	3625411 000		Valvola Scarico 24mm 250cc	Exhaust Valve 24mm 250cc	Valve Vidange 24mm 250cc	Auslassventil 24mm 250cc	Valvula Escape 24mm 250cc
3	3625329 000		Gambo Valvole	Gambo Valves	Tige Valves	Ventilschaftdichtung	Bravo Valvulas
6	3625409 000		Molla Conica Completa Valvola 250cc	Valve Spring Conical Cpl. 250cc	Ressort Conique Compl. Valve 250cc	Ventilfedern Koni.Kpl.250cc	Muelle Conica Completa Valvula 250cc
9	3625416 000		Raccogliore Valvole Mk6 250cc	Valve Collet Mk6 250cc	Ramasseur Valves Mk6 250cc	Ventilkegelstück Mk6 250cc	Envase Valvulas Mk6 250cc
10	3625343 000		Vite Di Regolazione Valvole 6,0,75	Adjustment Screw M6x0,75 6,0,75	Vis Regulation Valves 6,0,75	Einstellschraube M6x0,75	Tornillo Regulacion Valvulas 6,0,75
11	3625344 000		Dado 6,0,75	Nut M6x0,75	Ecrou 6,0,75	Mutter M6x0,75	Dado 6,0,75
13	3625336 000		Albero Bilancere Brac. Valv. Aspiraz	Rocker Arm Shaft Intake	Arbre Balancier Bras Valve Aspiration	Kipphebelachse Einlass	Ciguenal Balance Brazo Valvula Aspiracion
14	3625337 000		Albero Bilancere Brac. Valv. Scarico	Rocker Arm Shaft Exhaust	Arbre Balancier Bras Valve Vidange	Kipphebelachse Auslass	Ciguenal Balance Brazo Valvula Escape
15	3625341 000		Tappo Albero Bilancere Braccio Valvole	End Cap Rocker Arm Shaft	Bouchon Arbre Balancier Bras Valves	Endkappe Kipphebelachse	Tapo Ciguenal Balance Brazo Valvulas
16	3625055 000		Anello Or 19,10x1,60 Nbr 70	O Ring 19,10x1,60 Nbr 70	Or 19,10x1,60 Nbr 70	O-Ring 19,10x1,60	Or 19,10x1,60 Nbr 70
17	3625339 000		Rondella Spessore In Alluminio 5,2x10x2	Shim Alu 5,2x10x2	Rondelle Epaisseur Alum. 5,2x10x2	Scheibe Alu 5,2x10x2	Arandela Espesor En Aluminio 5,2x10x2
18	3625063 000		Vite Tappo Alb. Bilac. Braccio Valv.5.08	Ah Screw M5x8	Vis Bouchon	Isk.Schraube M5x8	Tornillo Tapo Arbre Valvula 5.8
19	3625335 000		Albero Di Decompressione Completo	Decompression Shaft Cpl.	Arbre Decompression Complet	Dekowelle Kpl.	Ciguenal De Decompression Completo
20	3625050 000		Anello Or 5,10x1,60 Nbr 70	O Ring 5,10x1,60 Nbr 70	Or 5,10x1,60 Nbr 70	O-Ring 5,10x1,60	Or 5,10x1,60 Nbr 70
22	3625338 000		Molla Albero Decompressione	Decompression Lever Spring	Ressort Arbre Decompression	Dekohebelfeder	Muelle Ciguenal De Decompression
23	3625030 000		Anello Seeger 8x0,8	Circlip 8x0,8	Bague Seeger 8x0,8	Sicherungsring 8x0,8	8x0,8
30	3625413 000		Braccio Valvola Aspirazione Compl. 250	Rocker Arm Intake Cpl. 250cc	Bras Valve Aspiration Compl. 250cc	Kipphebel Einlass Kpl 250cc	Bravo Valvula Aspiracion Compl. 250cc
31	3625414 000		Braccio Valvola Scarico Compl. 250cc	Rocker Arm Exhaust Cpl. 250cc	Bras Valve Vidange Compl. 250cc	Kipphebel Auslass Kpl 250cc	Bravo Valvula Escape Compl. 250cc

**ALBERO BILANCIAMENTO VALVOLE E VALVOLE
VALVE DRIVE
VILEBREQUIN BALANCER VALVES ET VALVES
VENTILTRIEB
CIGUENAL BALANCA VÁLVULES Y VÁLVULES**

250CC / 2005-2006

TAV.8

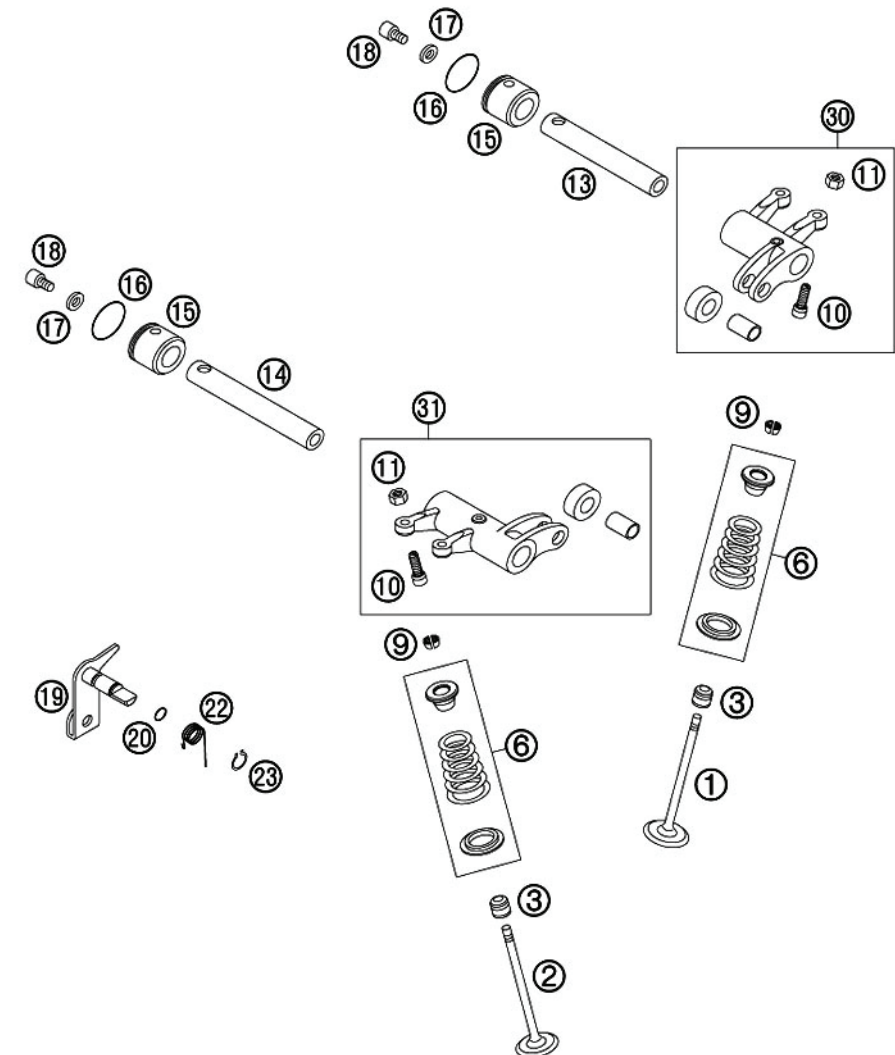

Pos Loc Pos Ps Pos	Numero Number Número Número Nummer	Nota Note Note Nota Anm.	Descrizione	Description	Désignation	Beschreibung	Descripción
1	3625331 000		Valvola Aspirazione 35mm 400/450/525cc	Intake Valve 35mm 400/450/525cc	Valve Aspiration 35mm 400/450/525cc	Einlassventil 35mm 400/450/525cc	Valvola Aspirazione 35mm 400/450/525cc
2	3625332 000		Valvola Scarico 30mm 400/450/525cc	Exhaust Valve 30mm 400/450/525cc	Valve Vidange 30mm 400/450/525cc	Auslassventil 30mm 400/450/525cc	Valvola 30mm 400/450/525cc
3	3625329 000		Gamba Valvole	Gamba Valves	Tige Valves	Ventilschaftdichtung	Brzo Valvulas
6	3625330 000		Molla Conica Compl.Valvola 400/450/525cc	Valve Spring Conical Cpl. 400/450/525cc	Ressort Compl. Valve 400/450/525cc	Ventilfedern Koni.Kpl.400/450/525cc	Muelle Conica Compl. Valvula 400/450/525cc
9	3625333 000		Raccoglitore Valvole Kk6 400/450/525cc	Valve Collet Kk6 400/450/525cc	Ramasseur Valves Kk6 400/450/525cc	Ventilkegelstück Kk6h 400/450/525cc	Envase Valvulas Kk6 400/450/525cc
10	3625343 000		Vite Di Regolazione Valvole 6,0,75	Adjustment Screw M6x0,75	Vis Regulation Valves 6,0,75	Einstellschraube M6x0,75	Tornillo Regulacion Valvulas 6,0,75
11	3625344 000		Dado 6,0,75	Nut M6x0,75	Ecaou 6,0,75	Mutter M6x0,75	Dado 6,0,75
13	3625336 000		Albero Bilancere Brac. Valv. Aspiraz	Rocker Arm Shaft Intake	Arbre Balancier Bras Valve Aspiration	Kipphebelachse Einlass	Ciguenal Balance Brazo Valvula Aspiracion
14	3625337 000		Albero Bilancere Brac. Valv. Scarico	Rocker Arm Shaft Exhaust	Arbre Balancier Bras Valve Vidange	Kipphebelachse Auslass	Ciguenal Balance Brazo Valvula Escape
15	3625341 000		Tappo Albero Bilancere Braccio Valvole	End Cap Rocker Arm Shaft	Bouchon Arbre Balancier Bras Valves	Endkappe Kipphebelachse	Tapa Ciguenal Balance Brazo Valvulas
16	3625055 000		Anello Or 19,10x1,60 Nbr 70	O Ring 19,10x1,60 Nbr 70	Or 19,10x1,60 Nbr 70	O-Ring 19,10x1,60	Or 19,10x1,60 Nbr 70
17	3625339 000		Rondella Spessore In Alluminio 5,2x10x2	Shim Alu 5,2x10x2	Rondelle Epaisseur Alum. 5,2x10x2	Scheibe Alu 5,2x10x2	Arandela Espesor En Aluminio 5,2x10x2
18	3625063 000		Vite Tappo Alb. Bilac. Braccio Valv.5.08	Ah Screw M5x8	Vis Bouchon	Isk.Schraube M5x8	Tornillo Tapa Arbre Valvula 5.8
19	3625335 000		Albero Di Decompressione Completo	Decompression Shaft Cpl.	Arbre Decompression Complet	Dekowelle Kpl.	Ciguenal De Decompression Completo
20	3625050 000		Anello Or 5,10x1,60 Nbr 70	O Ring 5,10x1,60 Nbr 70	Or 5,10x1,60 Nbr 70	O-Ring 5,10x1,60	Or 5,10x1,60 Nbr 70
22	3625338 000		Molla Albero Decompressione	Decompression Lever Spring	Ressort Arbre Decompression	Dekohebelfeder	Muelle Ciguenal De Decompression
23	3625030 000		Anello Seeger 8x0,8	Circlip 8x0,8	Bague Seeger 8x0,8	Sicherungsring 8x0,8	8x0,8
30	3625340 000		Braccio Valvola Aspiraz.Cpl.400/450/525cc	Rocker Arm Intake Cpl. 400/450/525cc	Bras Valve Aspiration Cpl 400/450/525cc	Kipphebel Einlass Kpl 400/450/525cc	Brazo Valvula Aspiracion 40/450/525cc
31	3625342 000		Braccio Valvola Scarico Cpl.400/450/525cc	Rocker Arm Exhaust Cpl 400/450/525cc	Bras Valve Echappement Cpl.400/450/525cc	Kipphebel Auslass Kpl 400/450/525cc	Brazo Valvula Escape 400/450/525cc

ALBERO BILANCIAMENTO VALVOLE E VALVOLE
VALVE DRIVE
VILEBREQUIN BALANCR VALVES ET VALVES
VENTILTRIEB
CIGUENAL BALANCA VÁLVULES Y VÁLVULES

400-450-525CC / 2005-2006

TAV.9

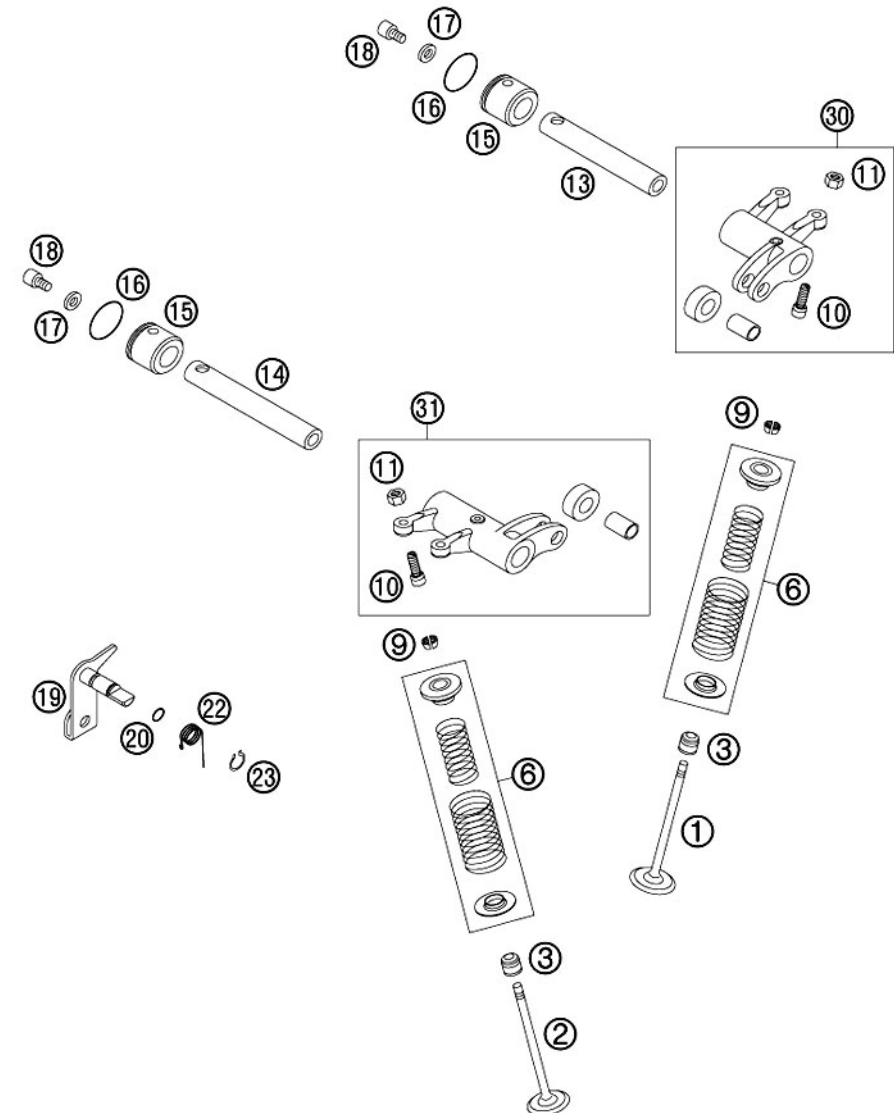

Pos Loc Pos Ps Pos	Numero Number Numéro Número Nummer	Nota Note Note Nota Anm.	Descrizione	Description	Désignation	Beschreibung	Descripción
1	3625319 000		Catena Di Distribuzione(96)400/450/525cc	Timing Chain 96 Rolls, 400/450/525cc	Chaîne De Distribution (96)400/450/525cc	Steuerkette 96 Rollen 400/450/525cc	Cadena De Distribucion(96) 400/450/525cc
1	3625407 000		Catena Di Distribuzione (94) 250cc	Timing Chain 94 Rolls, 250cc	Chaîne De Distribution (94) 250cc	Steuerkette 94 Rollen 250cc	Cadena De Distribucion(94) 250cc
3	3625311 000		Guida Catena Di Distribuzione	Timing Chain Guide	Guide Chaîne De Distribution	Steuerkettenführung	Guía Cadena De Distribucion
4	3625324 000		Guida Inferiore Catena Di Distribuzione	Securing Timing Chain Guide	Guide Inf. Chaîne De Distribution	Ausfallsicherung	Guía Inf. Cadena De Distribucion
5	3625321 000		Ingranaggio Catena Trasmisione 18t	Timing Gear 18-T	Engranaage Chaîne Transmission 18t	Steuerritzel 18-Z	Engranaaje Cadena Trasmision 18t
6	3625313 000		Tensionatore Catena Trasmisione	Timing Chain Tensionener	Tendeur De Chaîne Transmission	Steuerkettenspannerschiene	Tensor Cadena Trasmision
7	3625315 000		Guarnizione Tensionatore Catena Trasmis.	Gasket Timing Chain Tensionener	Joint Tendeur Chaîne Transmission	Dichtung Steuerkettenspanner	Junta Tensor Cadena Trasmision
8	3625314 000		Tensionatore Catena Trasmis. Completo	Timing Chain Tensionener Cpl Rac.	Tendeur Chaîne Transmis. Complet	Steuerkettenspanner Kpl. Completo	Tensor Cadena Trasmision Completo
9	3625312 000		Distanziale 6,1x8,2x13,1	Spacer Bushing 6,1x8,2x13,1	Entretoise 6,1x8,2x13,1	Distanzbüchse 6,1x8,2x13,1	Distanciador 6,1x8,2x13,1
10	1149070 000		Bullone 6.20 Rs Ch 8	Bolt 6.20	Boulon 6.20 Rs Ch 8	Sk.Bundschaube M6x20 Sw=8	Tornillo 6.20 Rs Ch 8
11	3625005 000		Bullone 5.16 Rs Ch 8	Bolt 5.16	Boulon 5.16 Rs Ch 8	Sk.Bundschaube M5x16 Sw=8	Tornillo 5.16 Rs Ch 8
12	3625325 000		Distanz.Sup.Fis.Guida Inf.Catena Trasmis	Spacer Securing Guide	Entretoise Sup. Fix. Guide Inf. Chaîne T	Stützhülse 5,2x7x10x7,7	Distanziador Sup. Fij. Guia Inf. Cadena Trasmision
15	3625034 000		Guarnizione 6x10x1	Cu-Seal Ring 6x10x1	Joint 6x10x1	Cu-Dichtung 6x10x1	Junta 6x10x1
16	1150010 000		Bullone 6.25 Rs Ch 8	Bolt 6.25	Boulon 6.25 Rs Ch 8	Sk.Bundschaube M6x25 Sw=8	Tornillo 6.25 Rs Ch 8
17	1150300 000		Bullone 6.30 Rs Ch 8	Bolt 6.30	Boulon 6.30 Rs Ch 8	Sk.Bundschaube M6x30 Sw=8	Tornillo 6.30 Rs Ch 8
18	3625373 000		Distanziale	Spacer	Entretoise	Distanzbüchse	Distanciador
19	3625016 000		Rondella 6,4	Washer 6,4	Rondelle 6,4	Unterlegscheibe Din 125 A 6,4	Arandela 6,4
24	3625317 000		Albero A Camme 450/525cc	Camshaft 450/525cc	Arbre A Cames 450/525cc	Nockenwelle 450/525cc	Giguenal A Cammas 450/525cc
24	3625383 000		Albero A Camme 400cc	Camshaft 400cc	Arbre A Cames 400cc	Nockenwelle 400cc	Giguenal A Cammas 400cc
24	3625406 000		Albero A Camme 250cc	Camshaft 250cc	Arbre A Cames 250cc	Nockenwelle 250cc	Giguenal A Cammas 250cc
26	3625318 000		Ingranaggio Albero A Camme	Camshaft Gear	Engranaage Arbre A Cames	Nockenwellenrad	Engranaaje Giguenal A Cammas
27	3625322 000		Albero Auto Decompressione Vite 8.10	Auto Decompression Shaft	Arbre Decompression Vis 8.10	Autodekawelle Isk.Schraube M8x10	Giguenal Decompression Tornillo 8.10
29	3625075 000		Rondella 26,7x34x1,3	Washer 26,7x34x1,3	Rondelle 26,7x34x1,3	Scheibe 26,7x34x1,3	Arandela 26,7x34x1,3
32	3625347 000		Supporto Guarnizione Ventola Pompa Acqua	Gasket Support	Support Joint Pompe Eau	Dichtungsträger	Soporte Junta Ventola Bobmba Agua
33	3625346 000						

CATENA DI DISTRIBUZIONE
TIMING VALVE
CHAÎNE DE DISTRIBUTION
STEUERTRIEB
CADENA DISTRIBUCIÓN

250-400-450-525CC / 2005-2006

TAV.10

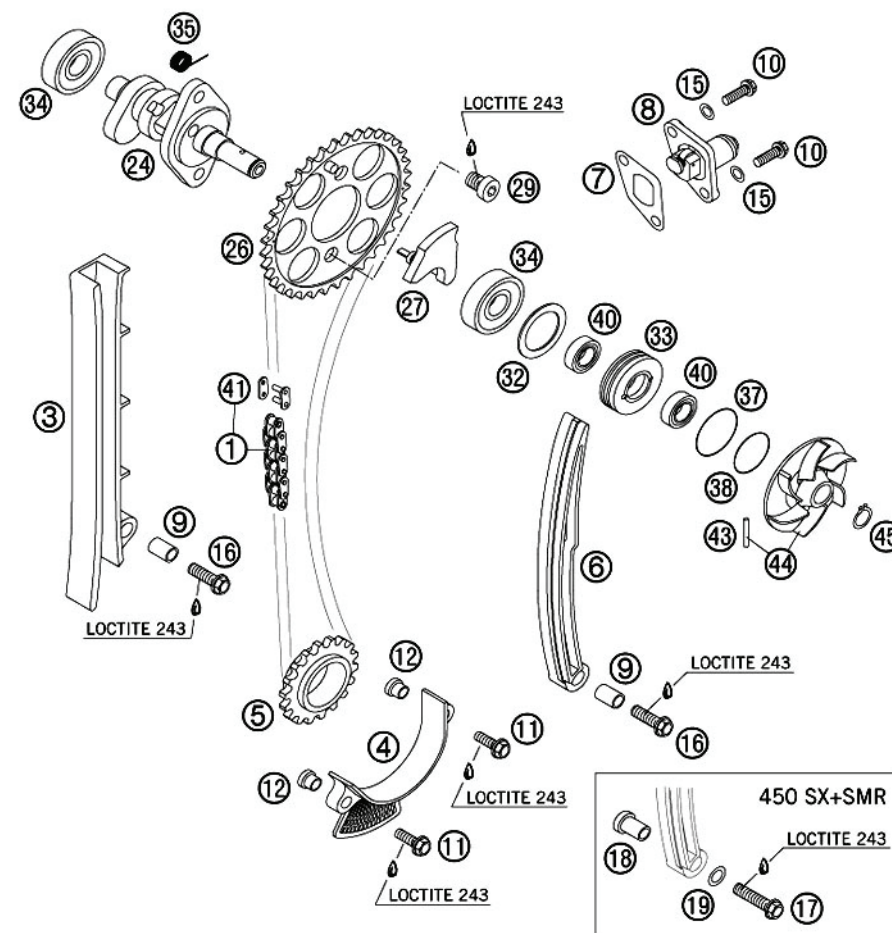

Pos Loc Pos Ps Pos	Numero Number Numéro Número Nummer	Nota Note Note Nota Anm.	Descrizione	Description	Désignation	Beschreibung	Description
34	3625038 000		Cuscinetto A Sfere 6201	Ball. Bearing 6201	Roulement 6201	Rillenkugellager 6201	Cojinete 6201
35	3625323 000		Molla Per Autodecompres- sore	Spring For Autodecompres- sion	Ressort	Feder Für Autodeko	Muelle
37	3625057 000		Anello Or 29,10x1,60 Nbr 70	O Ring 29,10x1,60 Nbr70	Or 29,10x1,60 Nbr 70	O-Ring 29,10x1,60	Or 29,10x1,60 Nbr 70
38	3625049 000		Anello Or 25,12x1,78 Nbr 70	O Ring 25,12x1,78 Nbr70	Or 25,12x1,78 Nbr 70	O-Ring 25,12x1,78	Or 25,12x1,78 Nbr 70
40	3625043 000		Anello Paraolio 10x18x4 Bsl	Shaft Seal Ring 10x18x4 Bsl	Joint Spy 10x18x4 Bsl	Wellendichtring 10x18x4	Junta Aceite 10x18x4
41	3625320 000		Maglia Giunzione Catena Trasmissione	Rivet Link For Timing Chain	Maille Chaine Transmission	Nietglied Für Steuerkette	Aganche Cadena Transmis- sion
43	3625020 000		Rullino 3,0 X 17,8	Needle Roller 3 X 17,8	Molette 3,0 X17,8	Nadelrolle 3x17,8	Rodilo 3,0x17,8
44	3625310 000		Ventola Pompa Acqua Com- pleta	Water Pump Wheel Cpl.	Ventilateur Pompe Eau Com- plete	Wasserpumpenrad Kpl.	Ventola Bomba Agua Com- pleta
45	3625080 000		Anello Seeger 10x1	Circlip 10x1	Bague Seeger 10x1	Sicherungsring 10x1	Anillo Seeger 10x1

CATENA DI DISTRIBUZIONE
TIMING VALVE
CHAÎNE DE DISTRIBUTION
STEUERTRIEB
CADENA DISTRIBUCIÓN

250-400-450-525CC / 2005-2006

TAV.10

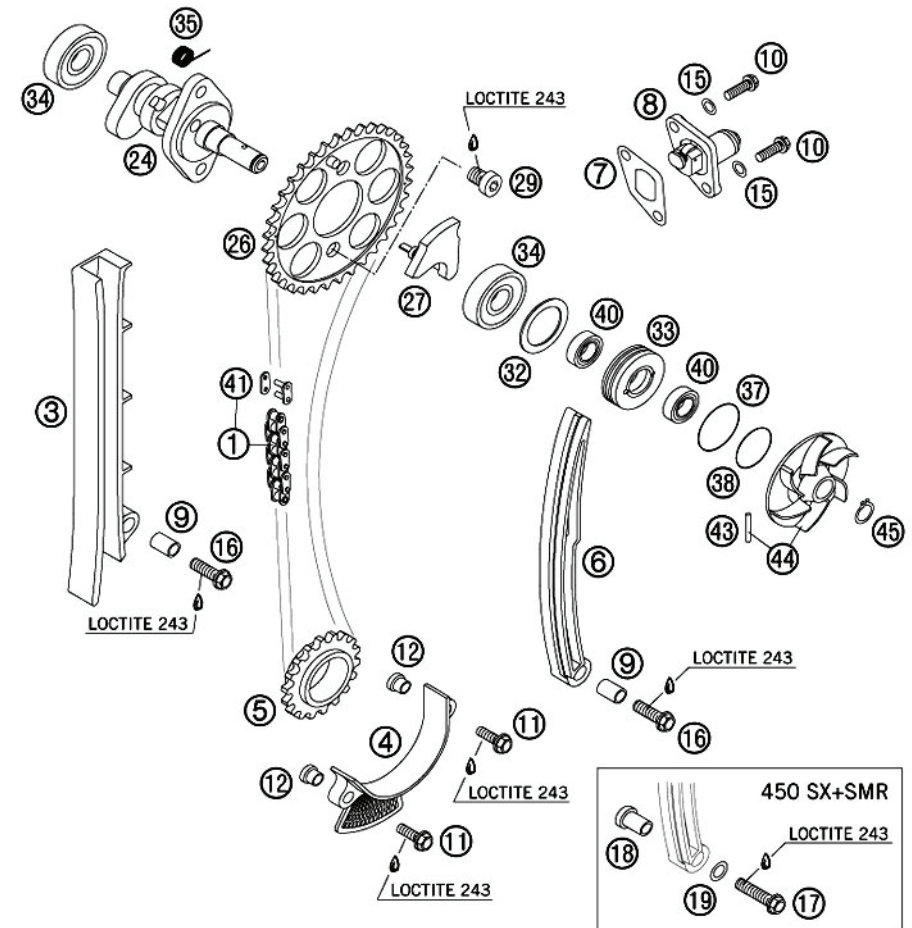

Pos Loc Pos Ps Pos	Numero Number Numéro Número Nummer	Nota Note Note Nota Anm.	Descrizione	Description	Désignation	Beschreibung	Descrìption
1	3625349 000		Albero Pompa Olio	Oil Pump Shaft	Arbre Pompe Huile	Ölpumpenwelle	Ciguelna Bomba Aceite
2	3625352 000		Rotore Completo Pompa Olio 10mm G-73r	Oilpump Rotor Cpl. 10mm G-73r	Rotor Complet Pompe Huile 10mm G-73r	Ölpumpenrotor Kpl. 10mm G-73r	Rotor Completo Bomba Aceite 10mm G-73r
3	3625353 000		Rotore Completo Pompa Olio 12mm G-95r	Oilpump Rotor Cpl. 10mm G-95r/003	Rotor Complet Pompe Huile 12mm G-95r	Ölpumpenrotor 12mm G-95r	Rotor Completo Bomba Aceite 12mm G-95r
4	3625196 000		Ingranaggio Pompa Olio 26-T	Oilpump Gear 26-T	Engranaage Pompe Huile 26-T	Ölpumpenrad 26-Z	Engranaje Bomba Aceite 26-T
5	3625351 000		Coperchio Pompa Olio Sinistro	Oilpump Cover L/S	Couvercle Pompe Huile Gauche	Ölpumpendeckel Links	Tapa Bomba Aceite Izquierdo
6	3625350 000		Coperchio Pompa Olio Destro 8mm	Oilpump Cover Rs 8mm	Couvercle Pompe Huile Droit 8mm	Ölpumpendeckel Rechts 8mm	Tapa Bomba Aceite Derecho 8mm
7	3625005 000		Bullone 5.16 Rs Ch 8	Bolt 5.16	Boulon 5.16 Rs Ch 8	Sk.Bundschrabe M5x16 Sw=8	Tornillo 5.16 Rs Ch 8
8	3625070 000		Vite 5.12	Ah Screw M5x12	Vis 5.12	Zyl.Schrabe M5x12 8.8	Tornillo 5.12
11	3625360 000		Coperchio Filtro Olio	Oil Filer Cover	Couvercle Filtre Huile	Ölfilterdeckel	Tapa Filtro Aceite
12	3625185 000		Filtro Olio (Lungo)	Oil Filer (Long)	Filtre Huile (Long)	Ölfilter Lang	Filtro Aceite
13	3625361 000		Filtro Olio (Corto)	Oil Filer (Short)	Filtre Huile (Court)	Ölfilter Kurz	Filtro Aceite
14	3625023 000		Rullino 2,5 X 19,8	Needle Roller 2,5 X 19,8	Molette 2,5x19,8	Nadelrolle 2,5x19,8	Rodillo 2,5x19,8
15	3625022 000		Rullino 2,5 X 11,8	Needle Roller 2,5 X 11,8	Molette 2,5x11,8	Nadelrolle 2,5x11,8	Rodillo 2,5x11,8
16	3625191 000		Bullone Forato M8x1	Banjo Bolt M8x1	Boulon M8x1	Hohlschraube M8x1	Tornillo M8x1
17	3625358 000		Bullone Forato M8x1 Ch 12 100	Banjo Bolt M8x1 Ws.12 100	Boulon M8x1 Ch 12 100	Düsenschrabe 100 M8x1 Sw=12	Tornillo M8x1 Ll.12 100
18	3625035 000		Guarnizione Olio 8x12x1	Seal Ring Cu 8x12x1	Joint Huile 8x12x1	Cu-Dichtring 8 X 12 X 1	Junta Aceite 8x12x1
19	3625359 000		Tubo Olio 400/450/525cc	Oil Pipe 400/450/525cc	Tube Huile 400/450/525cc	Ölleitung Stahl Gehäuse-Zkopf 400/450/525cc	Tubo Aceite 400/450/525cc
19	3625415 000		Tubo Olio 250cc	Oil Pipe 250cc	Tube Huile 250cc	Ölleitung Stahl Gehäuse-Zkopf 250cc	Tubo Aceite 250cc
20	3625059 000		Anello Or 40,00x2,50 Nbr 70	O Ring 40,00x2,50 Nbr 70	Bague 40,00x2,50 Nbr 70	O-Ring 40 X 2,50	Or 40,00x2,50 Nbr 70
21	3625357 000		Tappo M20x1,5 Ch.13	Plug M20x1,5 Ws 13	Bouchon M20x1,5 Cl.13	Verschl.Schrabe M20x1,5 Sw=13	Tapa M20x1,5 Ll.13
22	3625356 000		Filtro Olio 15x38mm	Oil Screen 15x38mm	Filtre Huile 15x38mm	Ölsieb 15x38mm	Filtro Aceite 15x38mm
23	3625053 000		Anello Or 12,5 X 1,5	O-Ring 12,5 X 1,5 Nbr	Bague 12,5x1,5	O-Ring 12,5 X 1,5	Or 12,5x1,5
24	3625048 000		Anello Or 17,17 X 1,78 Glo	O-Ring 17,17 X 1,78 Glo	Bague 17,17x1,78 Glo	O-Ring 17,17 X 1,78	Or 17,17x1,78 Glo
25	3625186 000		Rondella Serraggio Disco 8,1 X 15 X 0,5	Stop Disk 8,1 X 15 X 0,5	Rondelle Serrage Disque 8,1x15x0,5	Anlaufscheibe 8,1 X 15 X 0,5	Arandela Disque 8,1x15x0,5
26	3625060 000		Anello Seeger 6,0	Tab Washer 6,0	Bague Seeger 6,0	Sich.Scheibe 6,0	Seeger 6,0
27	3625192 000		Tampone In Gomma 8x17x10	Rubberbuffer 8x17x10	Tampon En Caoutchouc 8x17x10	Gummipuffer 8x17x10	Tampon En Goma 8x17x10

SISTEMA DI LUBRIFICAZIONE
LUBRICATING SYSTEM
POMPE À HUILE
SCHMIERSYSTEM
BOMBA DE ACEITE

250-400-450-525CC / 2005-2006

TAV.11

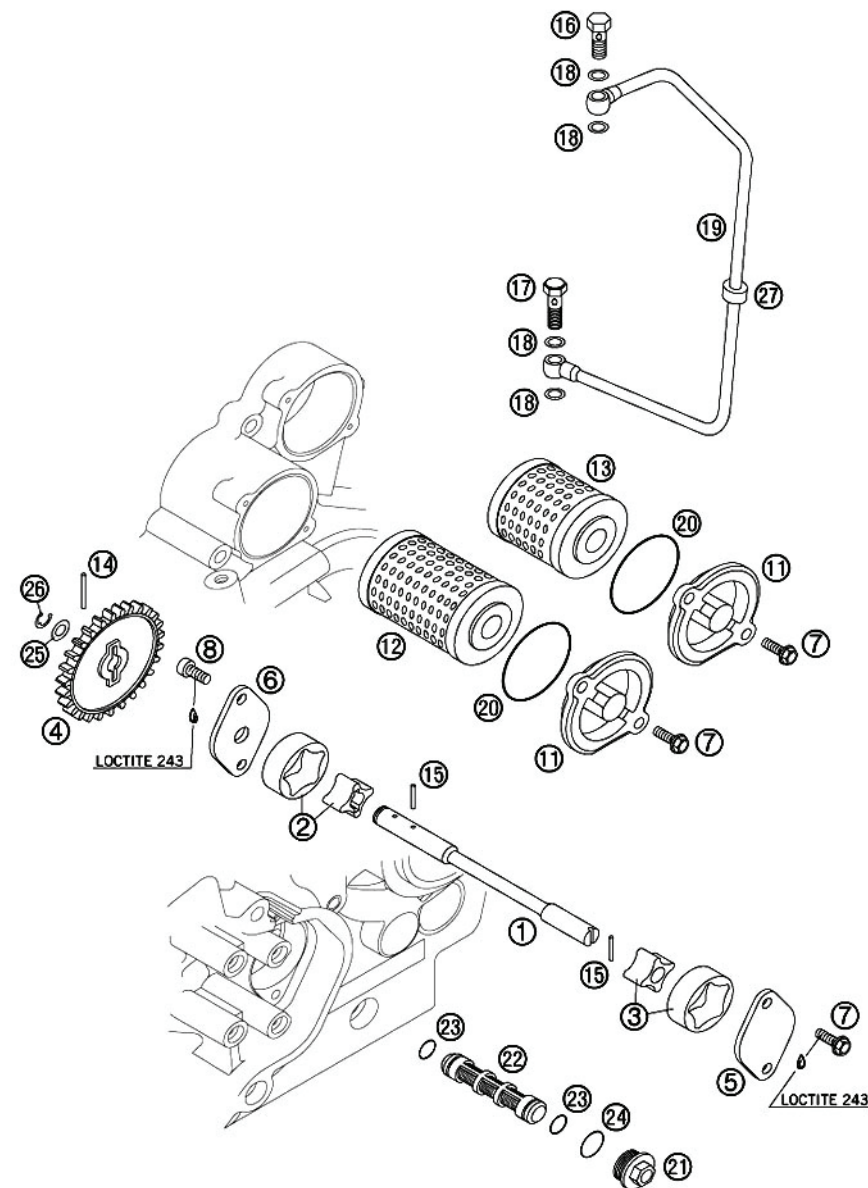

Pos Loc Pos Ps Pos	Numero Number Numéro Número Nummer	Nota Note Note Nota Anm.	Descrizione	Description	Désignation	Beschreibung	Descripción
1	1204901 000		Carburatore Motore 250 Rr4t	Carburettor, 250 Rr4t	Carbureteur Moteur 250 Rr4t	Vergaser Keihin Fcr Rr4t 250cc	Carburador Motor 250 Rr4t
5	3625146 000		Coperchio Carburatore	Carburetor Cover	Couvercle Carburateur	Vergaserdeckel	Tapa Carburador
10	3625164 000		Piastrina Per Cablaggio Carburatore	Bracket Plate For Thr.Cable	Plaqueette Cablage Carburateur	Halteblech Für Gasseile	Placa Carburador
11	3625158 000		Vite M5 X 8	Screw M5 X 8	Vis M5x8	Schraube M5x8	Tornillo M5x8
12	3625155 000		Albero Completo Valvola Carburatore	Throttle Shaft Cpl	Arbre Complet Valve Carburateur	Seilzugrolle Kpl.	Arbre Completo Valvula Carburador
14	3625156 000		Molla Albero Compl. Valvola Carburatore	Throttle Shaft Spring	Ressort Arbre Compl. Valve Carburateur	Feder Seilzugrolle	Muelle Arbre Completo Valvula Carburador
16	3625150 000		Braccetto Connessione Valvola Carb.	Link Arm Throttle Valve Cpl	Bras Jonction Valve Carburateur	Gasschieberarm Kpl.	Brazo Conexion Valvula Carburador
18	3625241 000		Distanziale Limitazione Valvola Carb	Slide Stop	Entretoise Valve Carburateur	Schieberanschlag	Distanciador Valvula Carburador
19	3625149 000		Valvola A Farfalla Carburatore	Throttle Valve Cpl	Valve Carburateur	Gasschieber Kpl.	Valvula Carburador
20	3625249 000		Cuscinetto Valvola A Farfalla Carb.	Bushing Throttle Valve	Roulement Valve Carburateur	Lagerrolle Gasschieber	Cojinete Valvula Carburador
21	3625151 000		Guarnizione Piastra Valvola A Farf. Carb.	Gasket, Throttle Valve Plate	Joint Plaque Valve Carburateur	Dichtpl. Gassch. Fcr-Mx	Junta Placa Valvula Carburador
22	3625250 000		Rondella Piastra Valvola A Farf. Carb.	Washer, Throttle Valve Plate	Rondelle Plaque Valve Carburateur	Dichtscheibe Gasschieber	Arandela Place Valvula Carburador
23	3625148 000		Spillo Keihin Obekt	Jet Needle Keihin Obekt	Epingle Keihin Obekt	Düsenadel Keihin Obekt	Aguja Keihin Obekt
23	3625244 000		Spillo Keihin Obetn	Jet Needle Keihin Obetn	Epingle Keihin Obetn	Düsenadel Keihin Obetn	Aguja Keihin Obetn
24	3625240 000		Anello Fissaggio Spillo Carburatore	Bar Clip	Bague Fixage Epingle Carburateur	Nadelclip	Anillo Fijacion Aguja Carburador
25	3625147 000		Kit Viti Fissaggio Spillo Carburatore	Needle Set Screw Cpl.	Jeu Vis Fixage Epingle Carburateur	Nadelschraube Kpl.	Juego Tornillos Fijacion Aguja Carburador
26	3625256 000		Sede Spillo Carburatore	Needle Jet Fcr-Mx	Place Epingle Carburateur	Nadeldüse Fcr-Mx	Sede Aguja Carburador
27	3625104 000		Getto Massimo 155 Keihin	Main Jet 155 Keihin	Jet Max 155 Keihin	Hauptdüse Gr.155 Keihin	Difusor Massimo 155 Keihin
27	3625105 000		Getto Massimo 158 Keihin	Main Jet 158 Keihin	Jet Max 158 Keihin	Hauptdüse Gr.158 Keihin	Difusor Massimo 158 Keihin
27	3625106 000		Getto Massimo 160 Keihin	Main Jet 160 Keihin	Jet Max 160 Keihin	Hauptdüse Gr.160 Keihin	Difusor Massimo 160 Keihin
27	3625107 000		Getto Massimo 162 Keihin	Main Jet 162 Keihin	Jet Max 162 Keihin	Hauptdüse Gr.162 Keihin	Difusor Massimo 162 Keihin
27	3625108 000		Getto Massimo 165 Keihin	Main Jet 165 Keihin	Jet Max 165 Keihin	Hauptdüse Gr.165 Keihin	Difusor Massimo 165 Keihin
27	3625109 000		Getto Massimo 168 Keihin	Main Jet 168 Keihin	Jet Max 168 Keihin	Hauptdüse Gr.168 Keihin	Difusor Massimo 168 Keihin
27	3625110 000		Getto Massimo 170 Keihin	Main Jet 170 Keihin	Jet Max 170 Keihin	Hauptdüse Gr.170 Keihin	Difusor Massimo 170 Keihin
28	3625100 000		Getto 38 Per Carburatore Keihin	Idle Jet 38 Keihin	Jet 38 Pour Carburateur Keihin	Leerlaufdüse Gr.38 Keihin	Difusor 38 Carburador Keihin
28	3625101 000		Getto 40 Per Carburatore Keihin	Idle Jet 40 Keihin	Jet 40 Carburateur Keihin	Leerlaufdüse Gr.40 Keihin	Difusor 40 Carburador Keihin
28	3625102 000		Getto 42 Per Carburatore Keihin	Idle Jet 42 Keihin	Jet 42 Pour Carburateur Keihin	Leerlaufdüse Gr.42 Keihin	Difusor 42 Carburador Keihin

CARBURATORE FCR-MX37
CARBURETOR, FCR-MX37
CARBURATEUR FCR-MX37
VERGASER, FCR-MX37
CARBURADOR FCR-MX37

250CC / 2005-2006

TAV.12

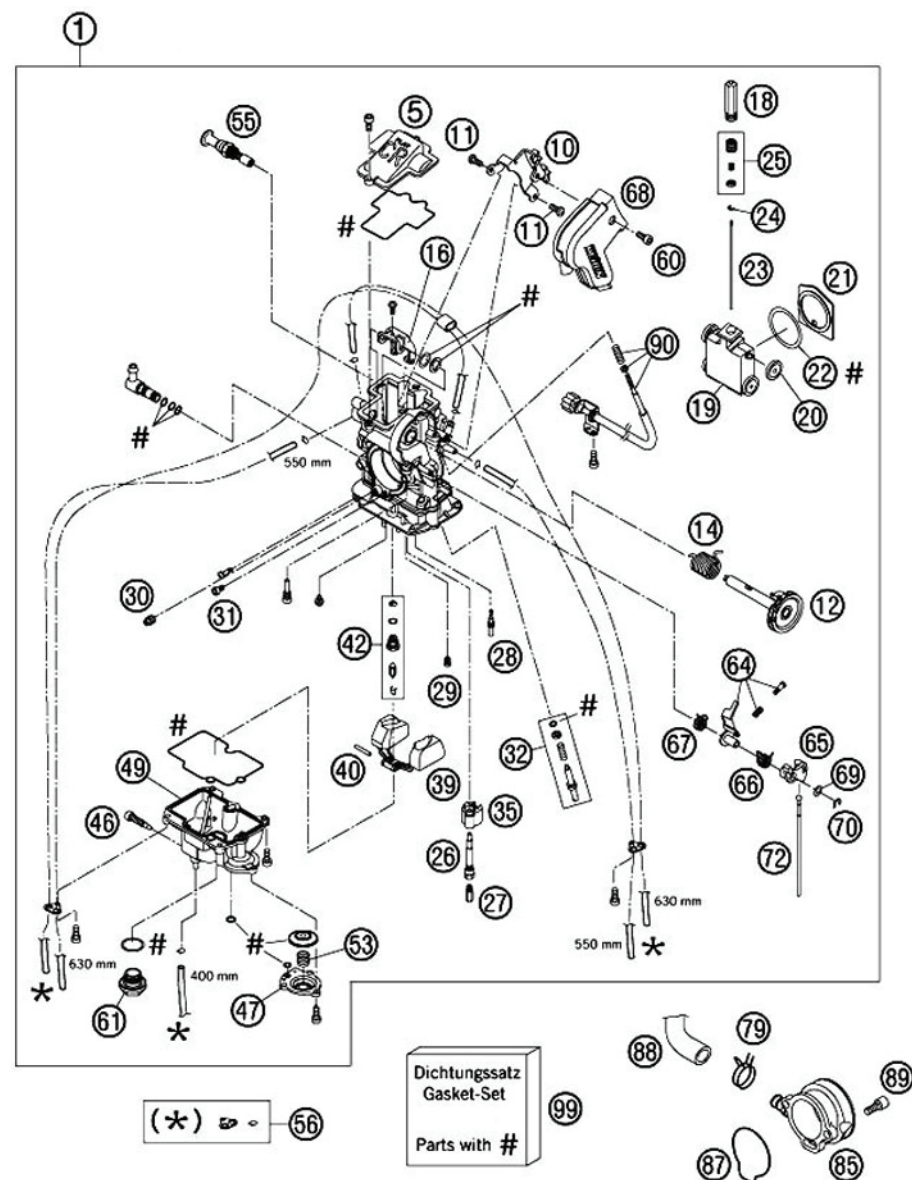

Pos Loc Pos Ps Pos	Numero Number Numéro Número Nummer	Nota Note Note Nota Anm.	Descrizione	Description	Désignation	Beschreibung	Descripción
28	3625103 000		Getto 45 Per Carburatore Keihin	Idle Jet 45 Keihin	Jet 45 Carburateur Keihin	Leerlaufdüse Gr.45 Keihin	Difusor 45 Carburador Keihin
28A	3625119 000		Fermo Per Spillo Carburatore Keihin	Needle Set Screw	Arret Epingle Carburateur Keihin	Nadelschraube Kpl.	Parado Aguja Carburador Keihin
29	3625253 000		Getto Starter 85 Per Carburatore Keihin	Starter Jet 85 Keihin	Jet Starter 85 Carburateur Keihin	Startdüse 85	Difusor Starter 85 Carburador Keihin
30	3625139 000		Getto Aria 100 Per Carburatore Keihin	Idle Air Jet 100 Keihin	Jet Air 100 Carburateur Keihin	Leerlaufdüse Gr.100 Keihin	Difusor Aire 100 Carburador Keihin
31	3625152 000		Getto Aria 200 Per Carburatore Keihin	Idle Air Jet 200 Keihin	Jet Air 200 Carburateur Keihin	Hauptluftdüse Gr.200 Keihin	Difusor Aire 200 Carburador Keihin
32	3625237 000		Kit Viti Cpl Fcr Per Carburatore Keihin	Adjust Screw Cpl. Fcr-Mx	Jeu Vis Cpl Fcr Carburateur Keihin	Gemischregulierschr. Kpl.Fcr-Mx	Juego Tornillos Carburador Keihin
35	3625166 000		Piastra Tampono Per Carburatore Keihin	Buffer Plate	Plaque Tampon Carburateur Keihin	Dämpfungskörper	Placa Tampon Carburador Keihin
39	3625141 000		Galleggiante Cpl Per Carburatore Keihin	Float Cpl	Flottant Cpl Carburateur Keihin	Schwimmer Kpl.	Flotante Carburador Keihin
40	3625140 000		Perno X Galleggiante Carburatore Keihin	Arm Pin Float	Pivot Flottant Carburateur Keihin	Stift Schwimmer	Eje Flotante Carburador Keihin
42	3625144 000		Kit Valvole Spillo Carburatore Keihin	Needle Valve Cpl	Kit Valves Aiguille Carburateur Keihin	Schwimmernadelventil Kpl.	Juego Valvulas Aguja Carburador Keihin
46	3625170 000		Vite Galleg. Spec. Carburatore Keihin	Drain Screw Float Chamber	Vis Flottant Spec. Carburateur Keihin	Ablassschraube Schwimmergeh.	Tornillo Flotante Espec. Carburador Keihin
47	3625161 000		Coperchio Pompa Accelerat. Carb. Keihin	Cover Accelerator Pump	Couvercle Pompe Acc. Carburateur Keihin	Gehäuse Beschleunigerpumpe	Tapa Bomba Acelerador Carburador Keihin
49	3625142 000		Camera Galleggiante Carburatore Keihin	Float Chamber	Flottant Carburateur Keihin	Schwimmergehäuse	Cama Flotante Carburador Keihin
53	3625254 000		Molla Pompa Carburatore Keihin	Coil Spring	Ressort Pompe Carburateur Keihin	Druckfeder	Muelle Bomba Carburador Keihin
55	3625157 000		Valvola Starte Cpl Carburatore Keihin	Starter Valve Cpl.	Valve Cpl Carburateur Keihin	Kaltstartbetätigung Kpl.	Valvula Starter Completa Carburador Keihin
56	3625168 000		Tubi Con Piastr. Fcr Compl. Carb. Keihin	Breath Hose Fcr-Mx Keihin Cpl.	Tubes A/Plaqueete Fcr Compl. Carb. Keihi	Entl.Schl. Fcr-Mx Keihin Kpl.	Tubos Con Placa Completo Carburador Keihin
60	3625154 000		Vite Coperchio Cpl Carburatore Keihin	Screw F. Cover	Vis Couvercle Cpl Carburateur Keihin	Schraube F.Abdeckung Keihin	Tornillo Tapa Carburador Keihin
61	3625143 000		Tappo Vaschetta Livello Benz.Carb.Keihin	Holding Bolt	Bouchon Cuvette Niveau Ess. Carb. Keihin	Verschlusschraube	Tapon Deposito Nivel Gasolina Carburador Keihin
64	3625163 000		Leva Interm. Completa Carburatore Keihin	Intermediate Lever Cpl	Lavier Complete Carburateur Keihin	Verbindungshebel Kpl.	Palanca Completa Carburador Keihin
65	3625159 000		Connessione Leva Carburatore Keihin	Link Lever	Jonction Levier Carburateur Keihin	Anlenkhebel	Conexion Palanca Carburador Keihin
66	3625160 000		Molla Connes. Leva Carburatore Keihin	Spring Link Lever	Ressort Levier Carburateur Keihin	Feder Anlenkhebel	Muelle Conexion Palanca Carburador Keihin

CARBURATORE FCR-MX37
CARBURETOR, FCR-MX37
CARBURATEUR FCR-MX37
VERGASER, FCR-MX37
CARBURADOR FCR-MX37

250CC / 2005-2006

TAV.12

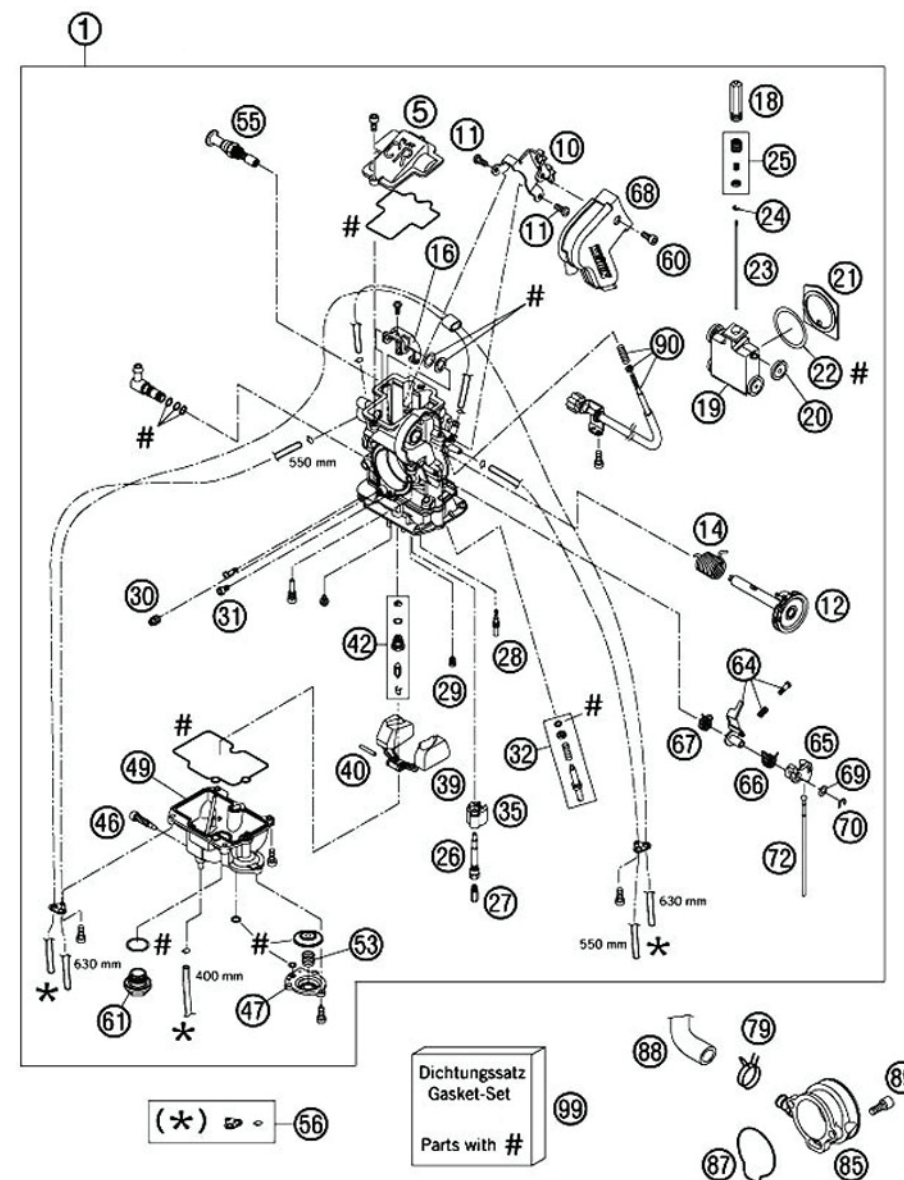

Pos Loc Pos Ps Pos	Numero Number Numéro Número Nummer	Nota Note Note Nota Anm.	Descrizione	Description	Désignation	Beschreibung	Descripción
67	3625171 000		Molla Interm. Leva Carburatore Keihin	Spring Intermediate Lever Keihin	Ressort Levier Carburateur Keihin	Feder Verbindungshebel Keihin	Muelle Palanca Carburador Keihin
68	3625153 000		Coperchio Cablag. Carburatore Keihin	Carburetor Cover Keihin	Couvercle Cablage Carburateur Keihin	Vergaser Abdeckung Keihin	Tapa Carburador Keihin
69	3625167 000		Rondella Connettere Leva Carb. Keihin	Washer Link Lever Carburetor Keihin	Rondelle Connecteur Levier Carb. Keihin	Scheibe Anlenkhebel Keihin	Arandela Conector Palanca Carburador Keihin
70	3625165 000		Anello Seeger	E-Clip	Bague Seeger	Sicherungsscheibe E-Form	Anillo Seeger
72	3625162 000		Asta Pompa Acceleratore Carb. Keihin	Rod Accelerator Pump Keihin	Etrier Pompe Acc. Carburateur Keihin	Gestänge Beschleunigerpumpe Keihin	Asta Bomba Acelerador Carburador Keihin
79	3625195 000		Anello Stringitubo Carb. Keihin	Ydnac-Clamp 16mm Keihin	Bague Tube Carburateur Keihin	Ydnac-Klammer 10173 (16mm)	Anillo Tubo Carburador Keihin
85	2719792 000		Raccordo Carbur. Mot.250/400/450/525 Exc	Intake Funnel	Raccord Carbur. Mot. 250/400/450/525 Exc	Ansaugtrichter Fcr Seitlich Offen	Enlace Carburador Motor 250/400/450/525 Exc
87	1067364 000		Anello Or Motore 250/400/450/525 Exc	O-Ring	Bague Moteur 250/400/450/525 Exc	O-Ring Für Ansaugtrichter	Or 250/400/450/525 Exc
88	3625252 000		Tubo Sfiato Motore	Engine Breather Tube	Tube Moteur	Motorenlüftungsschlauch	Tubo Motor
89	3625064 000		Vite M5x12	Ah Screw M5x12	Vis M5x12	Isk.Schraube M5x12	Tornillo M5x12
90	3625145 000		Kit Viti Stop Carburatore Keihin	Stop Screw Cpl Fcr-Mx Keihin	Jeu Vis Stop Carburateur Keihin	Stellschraube Kpl. Fcr-Mx Keihin	Juego Tornillos Stop Carburador Keihin
99	3625169 000		Kit Guarnizioni Carburatore Keihin	Gasket Set Fcr-Mx Keihin	Jeu Joints Carburateur Keihin	Dichtungssatz Keihin	Juego Junta Carburador Keihin

CARBURATORE FCR-MX37
CARBURETOR, FCR-MX37
CARBURATEUR FCR-MX37
VERGASER, FCR-MX37
CARBURADOR FCR-MX37

250CC / 2005-2006

TAV.12

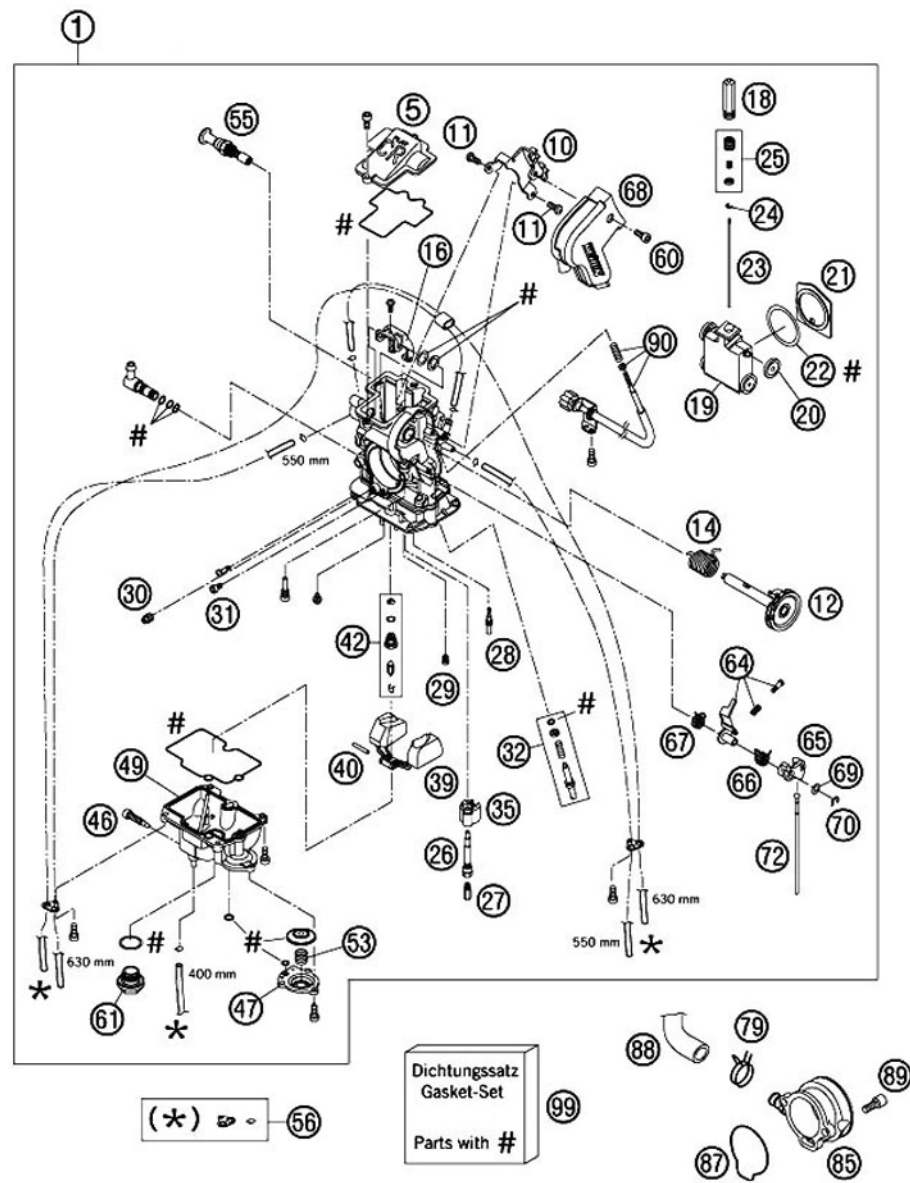

Pos Loc Pos Ps Pos	Numero Number Número Número Nummer	Nota Note Note Nota Anm.	Descrizione	Description	Désignation	Beschreibung	Descripción
1	1204902 000		Carburatore Motore 450 Exc	Carburettor, 450 Exc	Carbureteur Moteur 450 Exc	Vergaser Keihin Fcr Mx-39 450cc	Carburador Motor 450 Exc
1	1204904 000		Carburatore Motore 525 Exc	Carburettor, 525 Exc	Carbureteur Moteur 525 Exc	Vergaser Keihin Fcr Mx-39 525cc	Carburador Motor 525 Exc
1	1204906 000		Carburatore Motore 400 Exc	Carburettor, 400 Exc	Carbureteur Moteur 400 Exc	Vergaser Keihin Fcr Mx-39 400cc	Carburador Motor 400 Exc
5	3625146 000		Coperchio Carburatore	Carburetor Cover	Couvercle Carburateur	Vergaserdeckel	Tapa Carburador
10	3625164 000		Piastrina Per Cablaggio Carburatore	Carburetor Cover	Plaquette Cablage Carburateur	Halteblech Für Gasseile	Placa Carburador
11	3625158 000		Vite M5 X 8	Screw M5 X 8	Vis M5x8	Schraube M5x8	Tornillo M5x8
12	3625155 000		Albero Completo Valvola Carburatore	Throttle Shaft Cpl	Arbre Complet Valve Carburateur	Seilzugrolle Kpl.	Arbre Completo Valvula Carburador
14	3625156 000		Molla Albero Compl. Valvola Carburatore	Throttle Shaft Spring	Ressort Arbre Compl. Valve Carburateur	Feder Seilzugrolle	Muelle Arbre Completo Valvula Carburador
16	3625150 000		Braccetto Connessione Valvola Carb.	Link Arm Throttle Valve Cpl	Bras Jonction Valve Carburateur	Gasschieberarm Kpl.	Brazo Conexion Valvula Carburador
18	3625241 000		Distanziale Limitazione Valvola Carb	Slide Stop	Entretoise Valve Carburateur	Schieberanslag	Distanciador Valvula Carburador
19	3625149 000		Valvola A Farfalla Carburatore	Throttle Valve Cpl	Valve Carburateur	Gasschieber Kpl.	Valvula Carburador
20	3625249 000		Cuscinetto Valvola A Farfalla Carb.	Bushing Throttle Valve	Roulement Valve Carburateur	Lagerrolle Gasschieber	Cojinete Valvula Carburador
21	3625151 000		Guarnizione Piastra Valvola A Farf. Carb.	Gasket, Throttle Valve Plate	Joint Plaque Valve Carburateur	Dichtpl. Gassch. Fcr-Mx	Junta Placa Valvula Carburador
22	3625250 000		Rondella Piastra Valvola A Farf. Carb.	Washer, Throttle Valve Plate	Rondelle Plaque Valve Carburateur	Dichtscheibe Gasschieber	Arandela Placa Valvula Carburador
23A	3625119 000		Fermo Per Spillo Carburatore Keihin	Needle Set Screw	Arret Epingle Carburateur Keihin	Nadelschraube Kpl.	Parado Aguja Carburador Keihin
23	3625248 000		Spillo Obdtr Carbutaore Keihin Rr 4t	Jet Needle Obdtr Keihin	Epingle Obdtr Carburateur Keihin Rr4t	Düsenadel Keihin Obdtr	Aguja Obdtr Carburador Keihin Rr4t
23	3625420 000		Spillo Obdvr Carbutaore Keihin Rr 4t	Jet Needle Obdvr Keihin	Epingle Obdvr Carburateur Keihin Rr4t	Düsenadel Keihin Obdvr	Aguja Obdvr Carburador Keihin Rr4t
24	3625240 000		Anello Fissaggio Spillo Carburatore	Bar Clip	Bague Fixage Epingle Carburateur	Nadelclip	Anillo Fijacion Aguja Carburador
25	3625147 000		Kit Viti Fissaggio Spillo Carburatore	Needle Set Screw Cpl.	Jeu Vis Fixage Epingle Carburateur	Nadelschraube Kpl.	Juego Tornillos Fijacion Aguja Carburador
26	3625256 000		Sede Spillo Carburatore	Needle Jet Fcr-Mx	Place Epingle Carburateur	Nadeldüse Fcr-Mx	Sede Aguja Carburador
27	3625110 000		Getto Massimo 170 Keihin	Main Jet 170 Keihin	Jet Max 170 Keihin	Hauptdüse Gr.170 Keihin	Difusor Massimo 170 Keihin
27	3625111 000		Getto Massimo 172 Keihin	Main Jet 172 Keihin	Jet Max 172 Keihin	Hauptdüse Gr.172 Keihin	Difusor Massimo 172 Keihin
27	3625112 000		Getto Massimo 175 Keihin	Main Jet 175 Keihin	Jet Max 175 Keihin	Hauptdüse Gr.175 Keihin	Difusor Massimo 175 Keihin
27	3625113 000		Getto Massimo 178 Keihin	Main Jet 178 Keihin	Jet Max 178 Keihin	Hauptdüse Gr.178 Keihin	Difusor Massimo 178 Keihin
27	3625114 000		Getto Massimo 180 Keihin	Main Jet 180 Keihin	Jet Max 180 Keihin	Hauptdüse Gr.180 Keihin	Difusor Massimo 180 Keihin
27	3625115 000		Getto Massimo 182 Keihin	Main Jet 182 Keihin	Jet Max 182 Keihin	Hauptdüse Gr.182 Keihin	Difusor Massimo 182 Keihin

CARBURATORE FCR-MX39
 CARBURETOR, FCR-MX39
 CARBURATEUR FCR-MX39
 VERGASER, FCR-MX39
 CARBURADOR FCR-MX39

400-450-525CC / 2005-2006

TAV.13

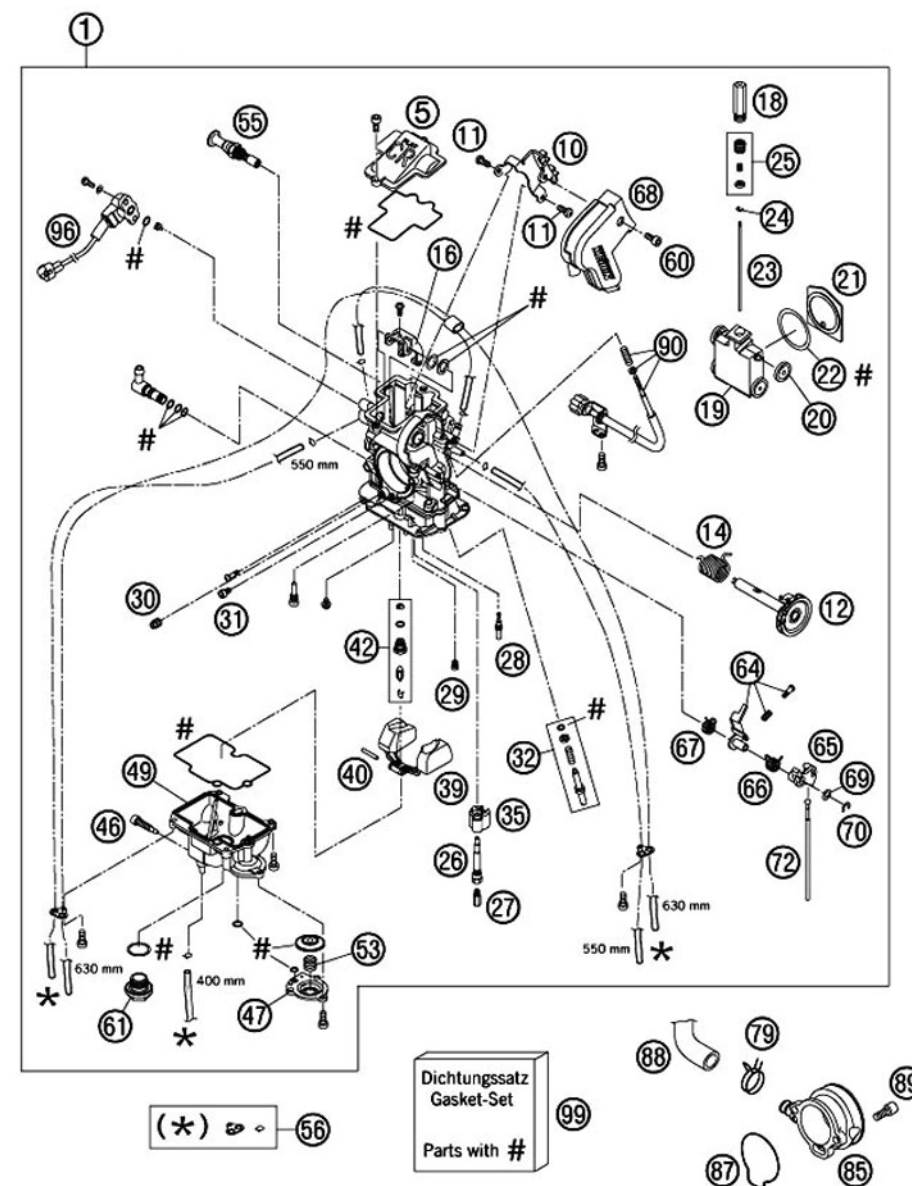

Pos Loc Pos Ps Pos	Numero Number Numéro Número Nummer	Nota Note Note Nota Anm.	Descrizione	Description	Désignation	Beschreibung	Descripción
27	3625116 000		Getto Massimo 185 Keihin	Main Jet 185 Keihin	Jet Max 185 Keihin	Hauptdüse Gr.185 Keihin	Difusor Maximo 185 Keihin
27	3625117 000		Getto Massimo 188 Keihin	Main Jet 188 Keihin	Jet Max 188 Keihin	Hauptdüse Gr.188 Keihin	Difusor Maximo 188 Keihin
27	3625118 000		Getto Massimo 190 Keihin	Main Jet 190 Keihin	Jet Max 190 Keihin	Hauptdüse Gr.190 Keihin	Difusor Maximo 188 Keihin
28	3625102 000		Getto 42 Per Carburatore Keihin	Idle Jet 42 Keihin	Jet 42 Pour Carburateur Keihin	Leerlaufdüse Gr.42 Keihin	Difusor 42 Carburador Keihin
28	3625103 000		Getto 45 Per Carburatore Keihin	Idle Jet 45 Keihin	Jet 45 Carburateur Keihin	Leerlaufdüse Gr.45 Keihin	Difusor 45 Carburador Keihin
29	3625253 000		Getto Starter 85 Per Carburatore Keihin	Starter Jet 85 Keihin	Jet Starter 85 Carburateur Keihin	Startdüse 85	Difusor Starter 85 Carburador Keihin
30	3625139 000		Getto Aria 100 Per Carburatore Keihin	Idle Air Jet 100 Keihin	Jet Air 100 Carburateur Keihin	Leerlaufdüse Gr.100 Keihin	Difusor Aire 100 Carburador Keihin
31	3625152 000		Getto Aria 200 Per Carburatore Keihin	Idle Air Jet 200 Keihin	Jet Air 200 Carburateur Keihin	Hauptluftdüse Gr.200 Keihin	Difusor Aire 200 Carburador Keihin
32	3625237 000		Kit Viti Cpl Fcr Per Carburatore Keihin	Adjust Screw Cpl. Fcr-Mx Keihin	Jeu Vis Cpl Fcr Carburateur Keihin	Gemischregulierschr. Kpl.Fcr-Mx Keihin	Juego Tornillos Carburador Keihin
35	3625166 000		Piastra Tampon Per Carburatore Keihin	Buffer Plate	Plaque Tampon Carburateur Keihin	Dämpfungskörper	Placa Tampon Carburador Keihin
39	3625141 000		Galleggiante Cpl Per Carburatore Keihin	Float Cpl	Flottant Cpl Carburateur Keihin	Schwimmer Kpl.	Flotante Carburador Keihin
40	3625140 000		Perno X Galleggiante Carburatore Keihin	Arm Pin Float	Pivot Flottant Carburateur Keihin	Stift Schwimmer	Eje Flotante Carburador Keihin
42	3625144 000		Kit Valvole Spillo Carburatore Keihin	Needle Valve Cpl	Kit Valves Aiguille Carburateur Keihin	Schwimmernadelventil Kpl.	Juego Valvulas Aguja Carburador Keihin
46	3625170 000		Vite Galleg. Spec. Carburatore Keihin	Drain Screw Float Chamber	Vis Flottant Spec. Carburateur Keihin	Ablassschraube Schwimmergeh.	Tornillo Flotante Espec. Carburador Keihin
47	3625161 000		Coperchio Pompa Accelerat. Carb. Keihin	Cover Accelerator Pump	Couvercle Pompe Acc. Carburateur Keihin	Gehäuse Beschleunigerpumpe	Tapa Bomba Acelerador Carburador Keihin
49	3625142 000		Camera Galleggiante Carburatore Keihin	Float Chamber	Flottant Carburateur Keihin	Schwimmergehäuse	Cama Flotante Carburador Keihin
53	3625254 000		Molla Pompa Carburatore Keihin	Coil Spring	Ressort Pompe Carburateur Keihin	Druckfeder	Muelle Bomba Carburador Keihin
55	3625157 000		Valvola Starte Cpl Carburatore Keihin	Starter Valve Cpl.	Valve Cpl Carburateur Keihin	Kaltstartbetätigung Kpl.	Valvula Starter Completa Carburador Keihin
56	3625168 000		Tubi Con Piastr. Fcr Compl. Carb.Keihin	Breath Hose Fcr-Mx Keihin Cpl.	Tubes A/Plaqueete Fcr Compl. Carb. Keihi	Entl.Schl. Fcr-Mx Keihin Kpl.	Tubos Con Placa Completo Carburador Keihin
60	3625154 000		Vite Coperchio Cpl Carburatore Keihin	Screw F. Cover	Vis Couvercle Cpl Carburateur Keihin	Schraube F.Abdeckung Keihin	Tornillo Tapa Carburador Keihin
61	3625143 000		Tappo Vaschetta Livello Benz.Carb.Keihin	Holding Bolt	Bouchon Cuvette Niveau Ess. Carb. Keihin	Verschlusschraube	Tapon Deposito Nivel Gasolina Carburador Keihin
64	3625163 000		Leva Interm. Completa Carburatore Keihin	Intermediate Lever Cpl	Levier Complete Carburateur Keihin	Verbindungshebel Kpl.	Palanca Completa Carburador Keihin
65	3625159 000		Connessione Leva Carburatore Keihin	Link Lever	Jonction Levier Carburateur Keihin	Anlenkhebel	Conexion Palanca Carburador Keihin

CARBURATORE FCR-MX39
 CARBURETOR, FCR-MX39
 CARBURATEUR FCR-MX39
 VERGASER, FCR-MX39
 CARBURADOR FCR-MX39

400-450-525CC / 2005-2006

TAV.13

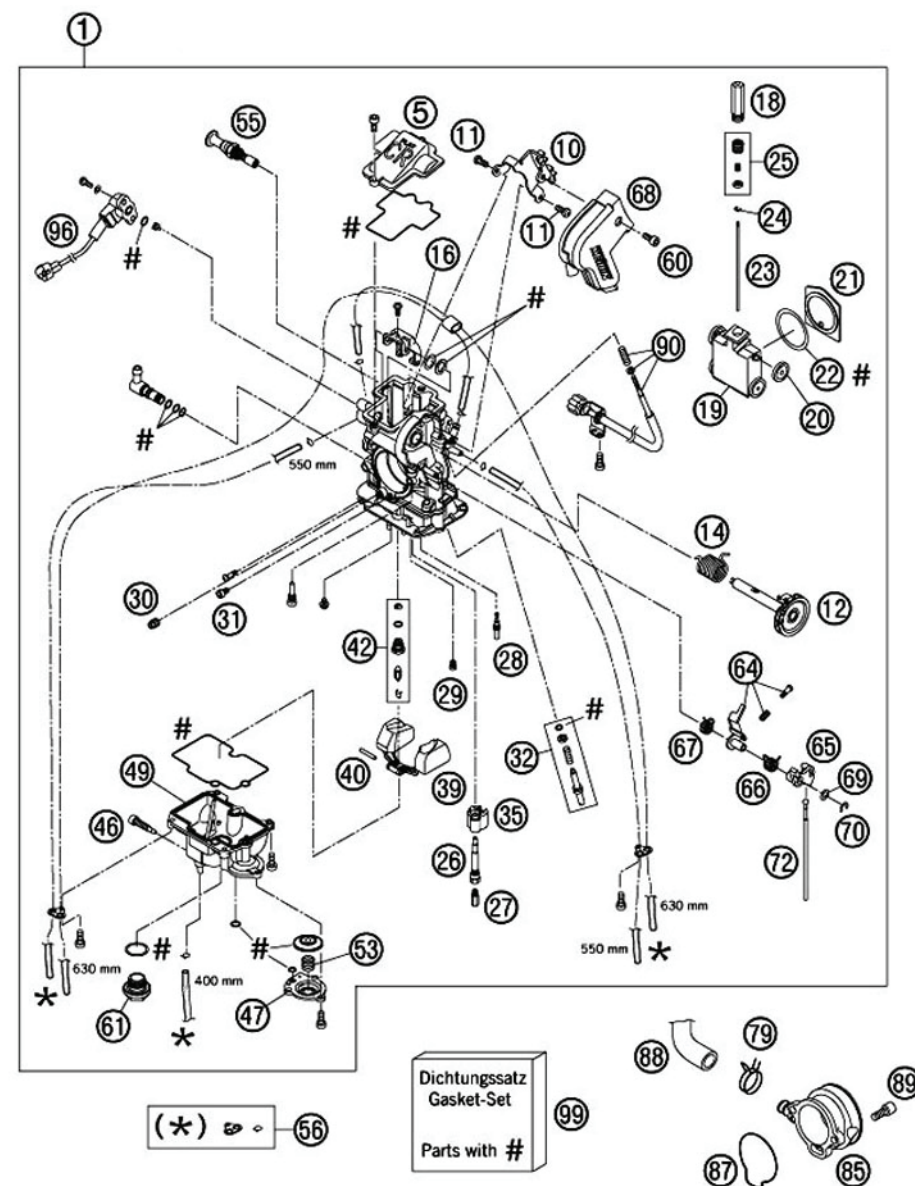

Pos Loc Pos Ps Pos	Numero Number Número Número Nummer	Nota Note Note Nota Anm.	Descrizione	Description	Désignation	Beschreibung	Descripción
66	3625160 000		Molla Connes. Leva Carburatore Keihin	Spring Link Lever	Ressort Levier Carburateur Keihin	Feder Anlenkhebel	Muelle Conexion Palanca Carburador Keihin
67	3625171 000		Molla Intern. Leva Carburatore Keihin	Spring Intermediate Lever	Ressort Levier Carburateur Keihin	Feder Verbindungshebel	Muelle Palanca Carburador Keihin
68	3625153 000		Coperchio Cablag. Carburatore Keihin	Carburetor Cover	Couvercle Cablage Carburateur Keihin	Vergaser Abdeckung	Tapa Carburador Keihin
69	3625167 000		Rondella Connettere Leva Carb. Keihin	Washer Link Lever Carburatore Keihin	Rondelle Connecteur Levier Carb. Keihin	Scheibe Anlenkhebel	Arandela Conector Palanca Carburador Keihin
70	3625165 000		Anello Seeger	E-Clip	Bague Seeger	Sicherungsscheibe E-Form	Anillo Seeger
72	3625162 000		Asta Pompa Acceleratore Carb. Keihin	Rod Accelerator Pump	Etrier Pompe Acc. Carburateur Keihin	Gestänge Beschleunigerpumpe	Asta Bomba Acelerator Carburador Keihin
79	3625195 000		Anello Stringitubo Carb. Keihin	Ydnac-Clamp 16mm	Bague Tube Carburateur Keihin	Ydnac-Klammer 10173 (16mm)	Anillo Tubo Carburador Keihin
85	2719792 000		Raccordo Carbur. Mot.250/400/450/525 Exc	Intake Funnel	Raccord Carbur. Mot. 250/400/450/525 Exc	Ansaugtrichter Fcr Seitlich Offen	Enlace Carburador Motor 250/400/450/525 Exc
87	1067364 000		Anello Or Motore 250/400/450/525 Exc	O-Ring	Bague Moteur 250/400/450/525 Exc	O-Ring Für Ansaugtrichter	Or 250/400/450/525 Exc
88	3625252 000		Tubo Sfiato Motore	Engine Breather Tube	Tube Moteur	Motorenlüftungsschlauch	Tubo Motor
89	3625064 000		Vite M5x12	Ah Screw M5x12	Vis M5x12	Isk.Schraube M5x12	Tornillo M5x12
90	3625145 000		Kit Viti Stop Carburatore Keihin	Stop Screw Cpl Fcr-Mx	Jeu Vis Stop Carburateur Keihin	Stellschraube Kpl. Fcr-Mx	Juego Tornillos Stop Carburador Keihin
96	3625255 000		Sensore Posizione Valvola A Farfalla	Throttle Position Sensor	Sensor Position Valve	Sensor Gasschieberposition	Sensor Valvula
99	3625169 000		Kit Guarnizioni Carburatore Keihin	Gasket Set Fcr-Mx	Jeu Joints Carburateur Keihin	Dichtungssatz	Juego Junta Carburador Keihin

CARBURATORE FCR-MX39
CARBURETOR, FCR-MX39
CARBURATEUR FCR-MX39
VERGASER, FCR-MX39
CARBURADOR FCR-MX39

400-450-525CC / 2005-2006

TAV.13

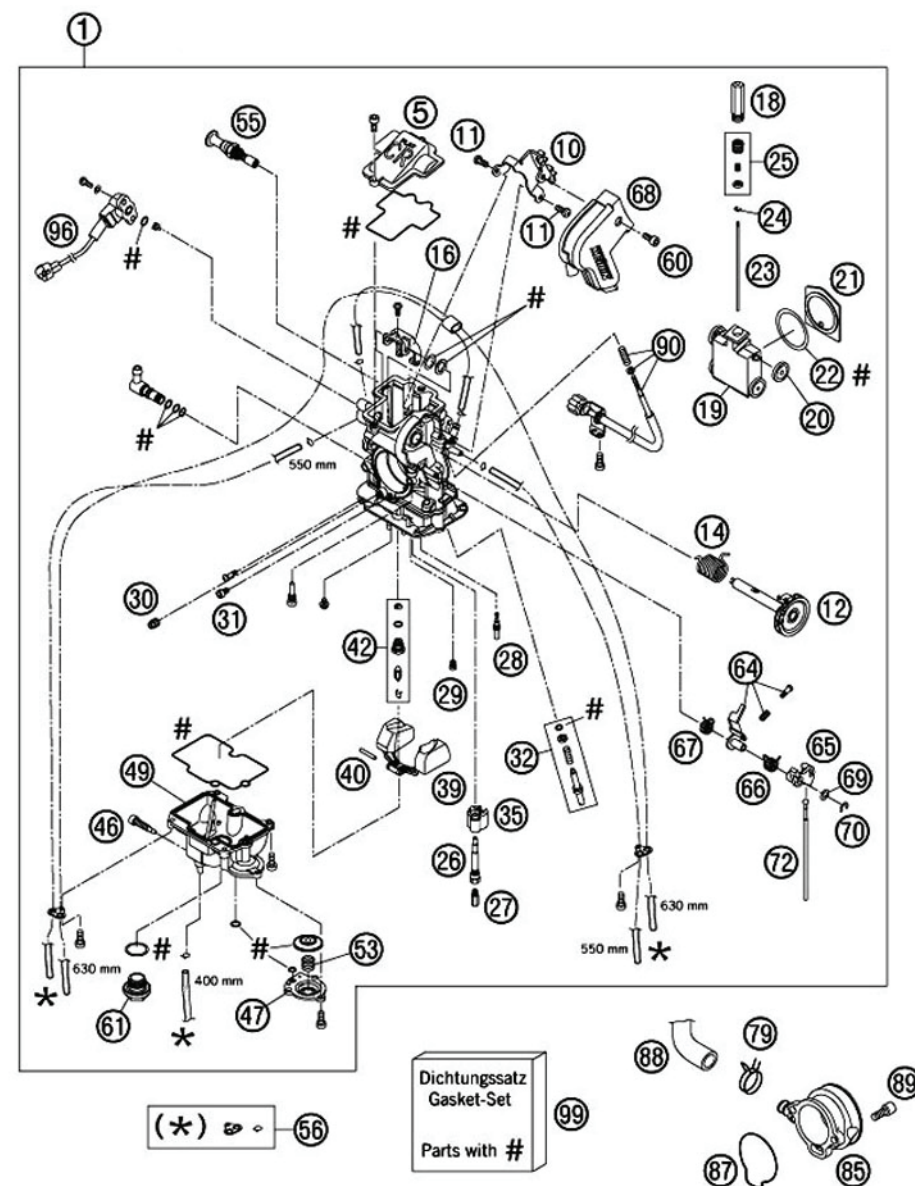

Pos Loc Pos Ps Pos	Numero Number Numéro Número Nummer	Nota Note Note Nota Anm.	Descrizione	Description	Désignation	Beschreibung	Description
1	3625213 000		Coperchio Volano	Ignition Cover Beta	Couvercle Volant	Zündungsdeckel Pulverbeschichtet	Tapa Volante Magnetico
2	3625229 000		Guarnizione Coperchio Volano	Ignition Cover Gasket 0,8mm	Joint Couvercle Volant	Zündungsdeckeldichtung 0,8mm	Junta Tapa Volante
3	3625364 000		Statore Volano 4k3b	Stator Cpl.	Stator Volant 4k3b	Stator Kpl	Stator Volante Magnetico 4k3b
4	3625365 000		Rotore Volano 4k3b	Flywheel Cpl. 4k3b	Rotor Volant 4k3b	Rotor	Rotor Volante Magnetico 4k3b
5	3625362 000		Generatore Rotativo Di Impulsi Kokusan	Pfser Coil Kokusan 4k3-A/B	Stator Kokusan	Impulsgeber Kpkusan	Stator Kokusan
6	1241847 800		Centralina Cdi Motore 250 Exc	Cdi Unit 250cc	Cdi Moteur 250 Exc	Digitalbox 250cc	Cdi Motor 250exc
6	1241848 800		Centralina Cdi Motore 450 Exc	Cdi Unit 450cc	Cdi Moteur 450 Exc	Digitalbox 450cc	Cdi Motor 450 Exc
6	1241849 800		Centralina Cdi Motore 400/525 Exc	Cdi Unit 400/525cc	Cdi Moteur 400/525 Exc	Digitalbox 400/525cc	Cdi Motor 400/525 Exc
8	2713553 000		Raccordo Candela 250/400/450/525 Exc	Spark Plug Cap	Raccord Bougie 250/400/450/525 Exc	Zündkerzenstecker Vd05eg	Enlace Bujia 250/400/450/525 Exc
9	3625363 000		Candela Ngk Dcpr8e	Spark Plug Ngk Dcpr8e	Bougie Ngk Dcpr8e	Zündkerze Ngk Dcpr8e	Bujia Ngk Dcpr8e
10	3625214 000		Supporto Filo	Support For Wire	Support Fil	Halteblech Für Kabel	Soporte Fil
11	3625014 000		Bullone M4 X 6	Screw M4 X 6	Boulon M4x6	Zyl.Schraube M4x6	Tornillo M4x6
12	3625377 000		Impianto Elettrico Cdi	Wiring Harness For Cdi	Systeme Electrique Cdi	Kabelstrang F. Cdi-Box	Sistema Electrico Cdi
16	1120694 800		Bobina Motore 250/400/450/525 Exc	Ignition Coil	Bobine Moteur 250/400/450/525 Exc	Zündspule Kokusan	Bobina Motor 250/400/450/525 Exc
20	3625085 000		Fascetta 100/2,5mm	Cable Tie 100/2,5mm	Collier 100/2,5mm	Kabelband 100/2,5mm Schwarz	Brida 100/2,5mm
29	3625087 000		Grano Di Riferimento 9,8 X 7 X 10	Dowel 9,8 X 7 X 10	Grain 9,8x7x10	Passhülse 9,8 X 7 X 10	Grano 9,8x7x10
30	3625009 000		Bullone 6.35 Rs Ch 8	Bolt 6.35	Boulon 6.35 Rs Ch 8	Sk.Bundschaube M6x35 Sw=8	Tornillo 6.35 Rs Ch 8
31	1150300 000		Bullone 6.30 Rs Ch 8	Bolt 6.30	Boulon 6.30 Rs Ch 8	Sk.Bundschaube M6x30 Sw=8	Tornillo 6.30 Rs Ch 8
32	1149070 000		Bullone 6.20 Rs Ch 8	Bolt 6.20	Boulon 6.20 Rs Ch 8	Sk.Bundschaube M6x20 Sw=8	Tornillo 6.20 Rs Ch 8
34	3625005 000		Bullone 5.16 Rs Ch 8	Bolt 5.16	Boulon 5.16 Rs Ch 8	Sk.Bundschaube M5x16 Sw=8	Tornillo 5.16 Rs Ch 8
35	3625003 000		Bullone M6 X 10	Hh Collar Screw M6x10	Boulon M6x10	Sk.Bundschaube M6x10 Sw=8	Tornillo M6x10
36	1148025 000		Bullone 6.16 Rs Ch 8	Bolt 6.16	Boulon 6.16 Rs Ch 8	Sk.Bundschaube M6x16 Sw=8	Tornillo 6.16 Rs Ch 8

SISTEMA DI IGNEZIONE 4K3B
IGNITION SYSTEM 4K3B
INSTALLATION ELECTRIQUE 4K3B
ZÜNDANLAGE 4K3B
INSTALACION ELECTRICA 4K3B

250-400-450-525CC / 2005-2006

TAV.14

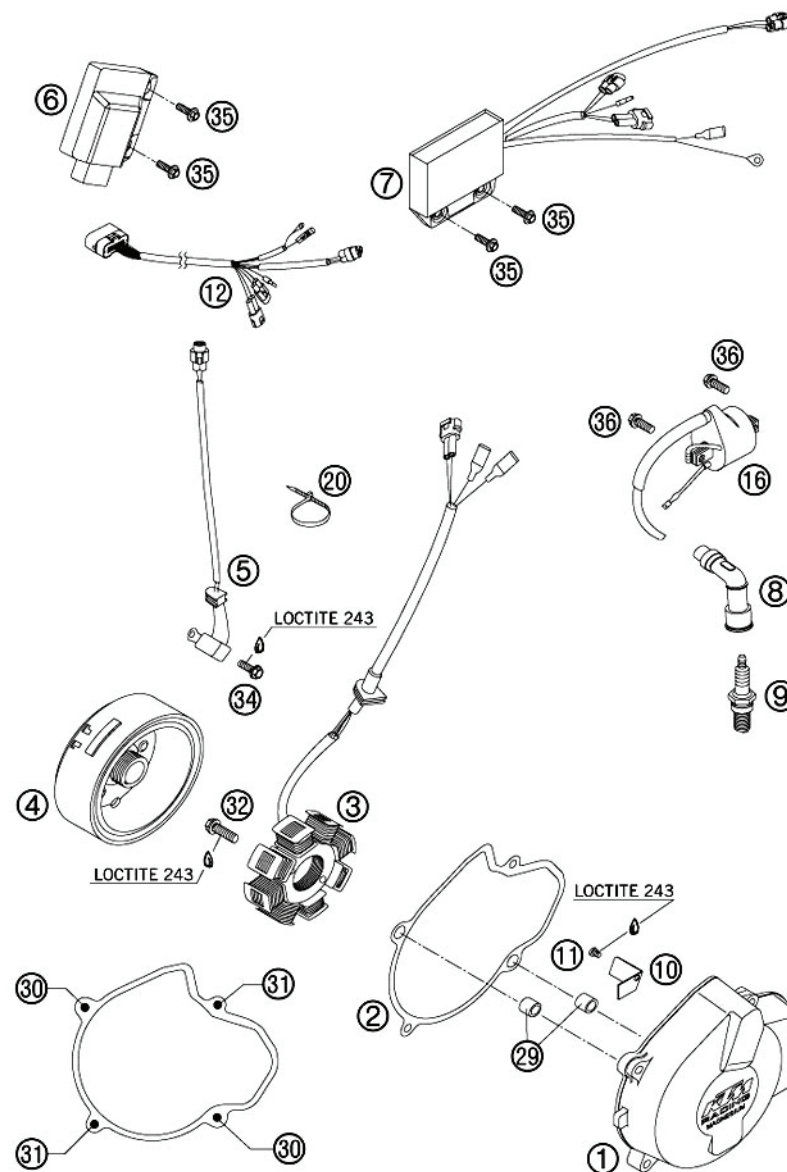

Pos Loc Pos Ps Pos	Numero Number Numéro Número Nummer	Nota Note Note Nota Anm.	Descrizione	Description	Désignation	Beschreibung	Descripción
1	3625366 000		Motorino Avviamento	E-Starter Engine	Demarreur	E-Starter Motor Kpl. 0,45kw	Motor Arranque
2	3625368 000		Ingranaggio Intermedio Mot.Avviamento	Intermediate Gear 58-T	Engranage Demarrage	Zwischenzahnrad 58-Z	Engranaje
3	3625123 000		Rondella Ferma Ingr. Mot. Av. 17,2x25x1	Stop Disk 17,2x25x1	Rondelle Arret Engr. Demar- rage 17,2x25x1	Anlaufscheibe 17,2x25x1	Arandela Engranaje Arranque 17,2x25x1
4	3625031 000		Anello 17 X 1	Cardip 17 X 1	Bague 17x1	Sicherungsring 17x1	Anillo 17x1
5	3625461 000	2006	Ingranaggio Riduzione	Reduction Gear	Pignon Réduction	Untersetzungs Zahnrad	Engranaje Reducción
8	3625024 000		Gabbia Ingranaggio Mot. Avviamento	Needle Bearing K 10x13x16 Tn	Cage Engranage Demarrage	Nadelkranz K10x13x16	Jaula Engranaje Arranque
9	3625370 000		Spinotto Gabbia Motorino Avviamento	Bearing Bolt	Goujon Cage Demarrage	Lagerbolzen	Pasador Jaula Motor De Arranque
10	3625369 000		Mozzo Ruota Libera	Free Wheel Hub	Moyeu Roue Libre	Freilaufnabe	Eje Rueda Libera
11	3625066 000		Vite M6x10	Screw M6x10	Vis M6x10	Isk.Schraube M6x10 10.9	Tornillo M6x10
12	3625251 000		Gabbia Hk 3016 B	Needle Bearing Hk 3016 B	Cage Hk 3016 B	Nadelhülse Hk 3016 B	Jaula Hk 3016 B
13	3625197 000		Ruota Libera Fwd	Free-Wheel Fwd	Roue Libre Fwd	Freilauf Fwd 332008 Bls	Rueda Libera Fwd
14	3625367 000		Ruota Libera Con Ingranag- gio Riduzione	Free Wheel With Recut G.75- 48/15-Z	Roue Libre Avec Engranage Reduction	Freilauf+Doppelzahn.75- 48/15-Z	Rueda Con Engranaje
14	3625463 000	2006	Ruota Libera	Freewheel	Roue Libre	Freilauf	Rueda Libre
15	1149070 000		Bullone 6.20 Rs Ch 8	Bolt 6.20	Boulon 6.20 Rs Ch 8	Sk.Bundschraube M6x20 Sw=8	Tornillo 6.20 Rs Ch 8
16	3625056 000		Anello Or 25,00x3,00 Nbr 70	O Ring 25,00x3,00 Nbr 70	Or 25,00x3,00 Nbr 70	O-Ring 25,00x3,00	Or 25,00x3,00 Nbr 70
17	3625371 000		Tappo	Cap Cover	Bouchon	Verschlussdeckel	Tapa
18	1147015 000		Bullone 6.12 Rs Ch 8	Bolt 6.12	Boulon 6.12 Rs Cle' 8	Sk.Bundschraube M6x12 Sw=8	Tornillo 6.12 Rs Ch 8
19	3625016 000		Rondella 6,4	Washer 6,4	Rondelle 6,4	Unterlegscheibe Din 125 A 6,4	Arandela 6,4

AVVIAMENTO ELETTRICO
ELECTRIC STARTER
ELECTRIQUE DEMARRAGE
ELEKTROSTARTER
ELECTRICA ARRANQUE

250-400-450-525CC / 2005-2006

TAV.15

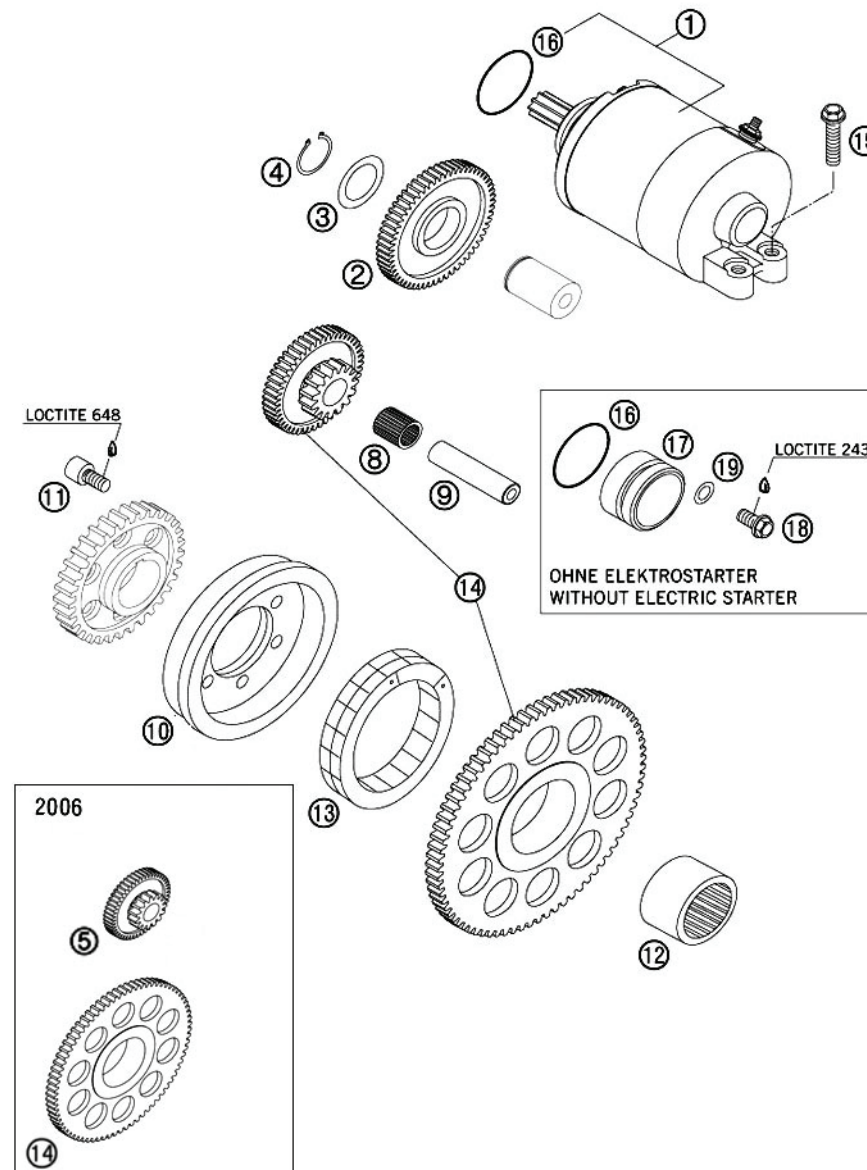

Pos Loc Pos Ps Pos	Numero Number Numéro Número Nummer	Nota Note Note Nota Anm.	Descrizione	Description	Désignation	Beschreibung	Descripción
1	3625258 000		Frizione Esterna	Outer Clutch	Embrayage Exterieur	Kupplungskorb 76-Z/20-Z Einsatz Gehärtet	Embrague Exterior
2	3625259 000		Mozzo Interno Frizione	Inner Clutch Hub	Moyeu Interieur Embrayage	Mitnehmer	Buje Interior Embrague
3	3625267 000		Disco Frizione 2mm	Lining Disc 2mm	Disque Embrayage 2mm	Belaglamelle 2mm	Disque Embrague 2mm
4	3625266 000		Disco Frizione Intermedio 1mm	Intermediate Disc 1mm	Disque Embrayage 1mm	Zwischenlamelle 1mm	Disque Embrague 1mm
5	3625260 000		Coperchio A Pres. Frizione Con Pas. Olio	Pressure Cap W. Oil Passage	Couvercle Embrayage	Druckkappe M.Ölbohrungen	Tapa Embrague
5	3625452 000	2006	Coperchio A Pres. Frizione Con Pas. Olio	Pressure Cap W. Oil Passage	Couvercle Embrayage	Druckkappe M.Ölbohrungen	Tapa Embrague
6	3625262 000		Molla Frizione 2,5x43mm	Clutch Spring 2,5x43mm	Ressort Embrayage 2,5x43mm	Kupplungsfeder 2,5x43mm	Muelle Embrague 2,5x43mm
7	3625263 000		Reggimolla Frizione 6,2x12x18x3,6mm	Spring Retainer 6,2x12x18x3,6mm	Porte-Ressort Embrayage 6,2x12x18x3,6 Mm	Federteller 6,2x12x18x3,6	Muelle Embrague 6,2x12x18x3,6 Mm
10	3625269 000		Asta Spingidisco Frizione 7x188mm	Push Rod 7x188mm	Etrier Disque Embrayage 7x188mm	Druckstange 7x189,6mm	Asta Disque Embrague 7x189,6mm
11	3625264 000		Rondella (Mezza)	Push Rod 7x188mm	Rondelle	Halbscheibe	Arandela
12	3625268 000		Rondella Di Supporto 25x35x1	Supportwasher 25x35x1	Rondelle 25x35x1	Stützscheibe 25x35x1	Arandela Soporte 25x35x1
13	3625073 000		Vite M6 X 25	Ah Screw M6 X 25	Vis M6x25	Isk.Schraube M6x25	Tornillo M6x25
14	3625029 000		Gabbia A Rulli 25x29x10	Needle Bear K 25x29x10	Cage 25x29x10	Nadelkranz K25x29x10	Jaula 25x29x10
15	3625257 000		Ingranaggio Primario 33 T	Primary Gear 33 T	Engrenage Primaire 33t	Primärrad 33-Z	Engranaje Primario 33t
16	1291895 033		Corpo Pompa Con Pistone Ø27	Output Cylinder Cpl.	Corps Pompe Avec Pist.Ø27	Nehmerzylinder Kpl.	Protector Bomba Con Piston Ø27
17	3625058 000		Anello Or 30,00x1,50 Nbr 70	O-Ring 30,00x1,50 Nbr 70	Or 30,00x1,50 Nbr 70	O-Ring 30,00x1,50	Or 30,00x1,50 Nbr 70
18	3625090 000		Siringa Per Olio Spurgo Frizione	Vent Injection Hydr. Clutch	Seringat Huile Embrayage	Entlüft.Spritze Hydr. Kupplung	Jeringa Aceite Embrague
19	3625272 000		Pistone Con Anello Or Corpo Pompa Friz.	Piston With O-Ring And Ball	Piston Avec Or Pompe Embrayage	Kolben Mit O-Ring Und Kugel	Piston Con Or Cuerpo Bomba Embrague
20	3183530 000		Vite Spec. Pompa Idraulica Magura	Magura Hydraulic Pump Special Screw	Vis Speciales Pompe Hydraulique Magura	Entüftungschr. Mit Kappe	Tornillo Espec. Bomba Idraulica Magura
21	3625009 000		Bullone 6.35 Rs Ch 8	Bolt 6.35	Boulon 6.35 Rs Ch 8	Sk.Bundschraube M6x35 Sw=8	Tornillo 6.35 Rs Ch 8
22	1149070 000		Bullone 6.20 Rs Ch 8	Bolt 6.20	Boulon 6.20 Rs Ch 8	Sk.Bundschraube M6x20 Sw=8	Tornillo 6.20 Rs Ch 8
23	3625265 000		Rondella Speciale Con Gradino	Stepped Washer	Rondelle Speciale	Stufenscheibe	Arandela Especial
24	3625271 000		Guarnizione Per Corpo Frizione	Gasket For Slave Cylinder	Joint Corp Embrayage	Dichtung Für Nehmerzylinder	Junta Cuerpo Embrague
26	3625261 000		Perno Guida Frizione	Driving Sleeve D=8, L=31	Pivot Guide Embrayage	Mitnahmehülse D=8,L=31	Eje Guia Embrague
26	3625465 000	2006	Perno Guida Frizione D=8,L=33	Driving Sleeve D=8, L=33	Pivot Guide Embrayage D=8,L=33	Mitnahmehülse D=8,L=33	Eje Guia Embrague D=8,L=33

FRIZIONE
CLUTCH
EMBRAYAGE
KUPPLUNG
EMBRAGUE

250-400-450-525CC / 2005
250CC / 2006

TAV.16

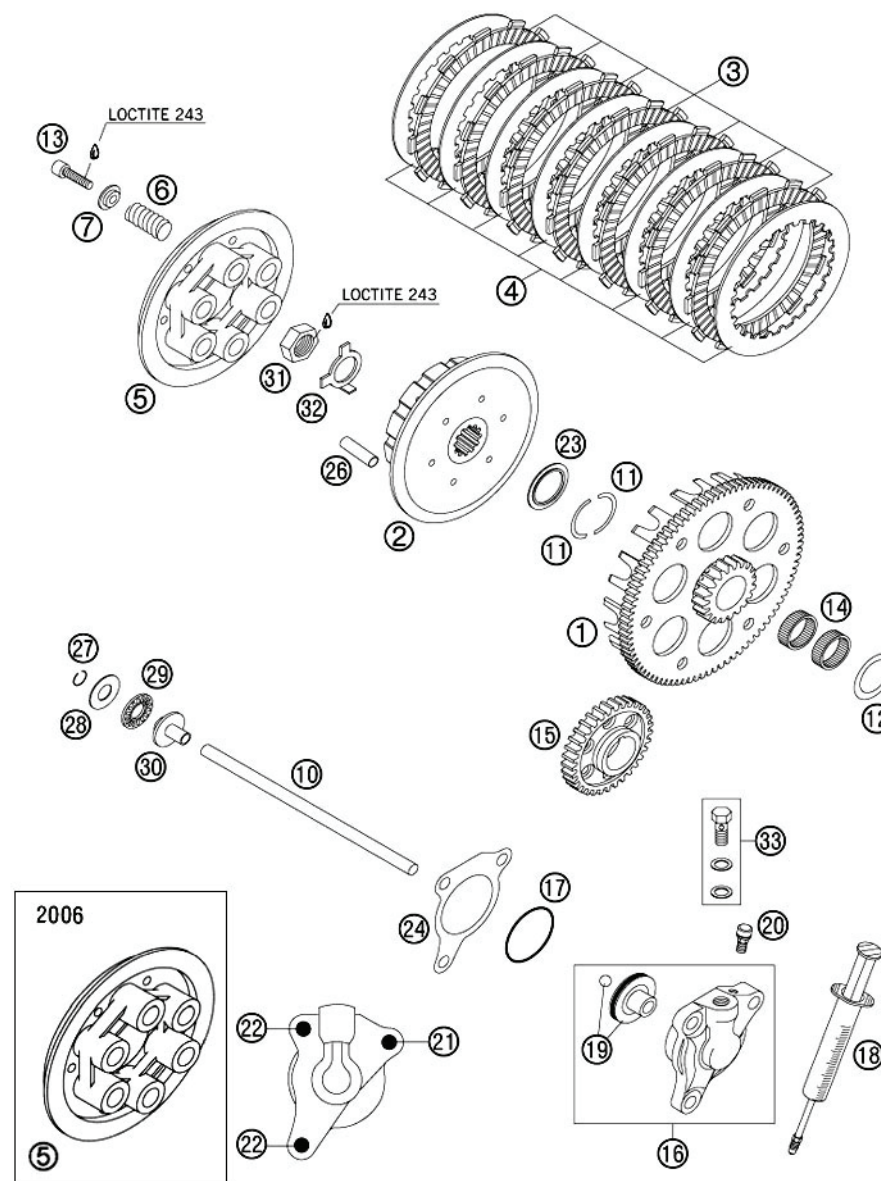

Pos Loc Pos Ps Pos	Numero Number Numéro Nùmero Nummer	Nota Note Note Nota Anm.	Descrizione	Description	Désignation	Beschreibung	Descripción
27	3625079 000		Anello Rw12	Cirdip Rw12	Bague Rw12	Sprengring Rw12	Anillo Rw12
28	3625131 000		Rondella 12x26x1	Axial Washer 12x26x1	Rondelle 12x26x1	Axialscheibe As1226 12x26x1	Arandela 12x26x1
29	3625130 000		Cuscinetto Asta Corpo Frizione	Axial Needle Bearing	Roulement Etrier Embrayage	Axiallager Axk 1226	Cojinete
30	3625092 000		Innesto Asta Corpo Frizione	Pressure Piece	Embrayage Etrier	Druckpilz 125-380	Embrague Asta Cuerpo Embrague
31	3625069 000		Dado M18 X 1,5	Hexagon Nut M18x1,5	Ecrou M18x1,5	Sk.Mutter M18x1,5	Dado M18x1,5
32	3625137 000		Rondella Di Bloccaggio Dado	Lock Washer	Rondelle Blocage Ecrou	Scherungsblech	Arandela Dado
33	3625270 000		Bullone Forato Corpo Frizione	Hollow Screw Hydr. Clutch Frizione	Boulon Corp Embrayage Cpl.	Hohlschraube Hydr.Kuppl.Kpl.	Tornillo Cuerpo Embrague

FRIZIONE
CLUTCH
EMBRAYAGE
KUPPLUNG
EMBRAGUE

250-400-450-525CC / 2005
250CC / 2006

TAV.16

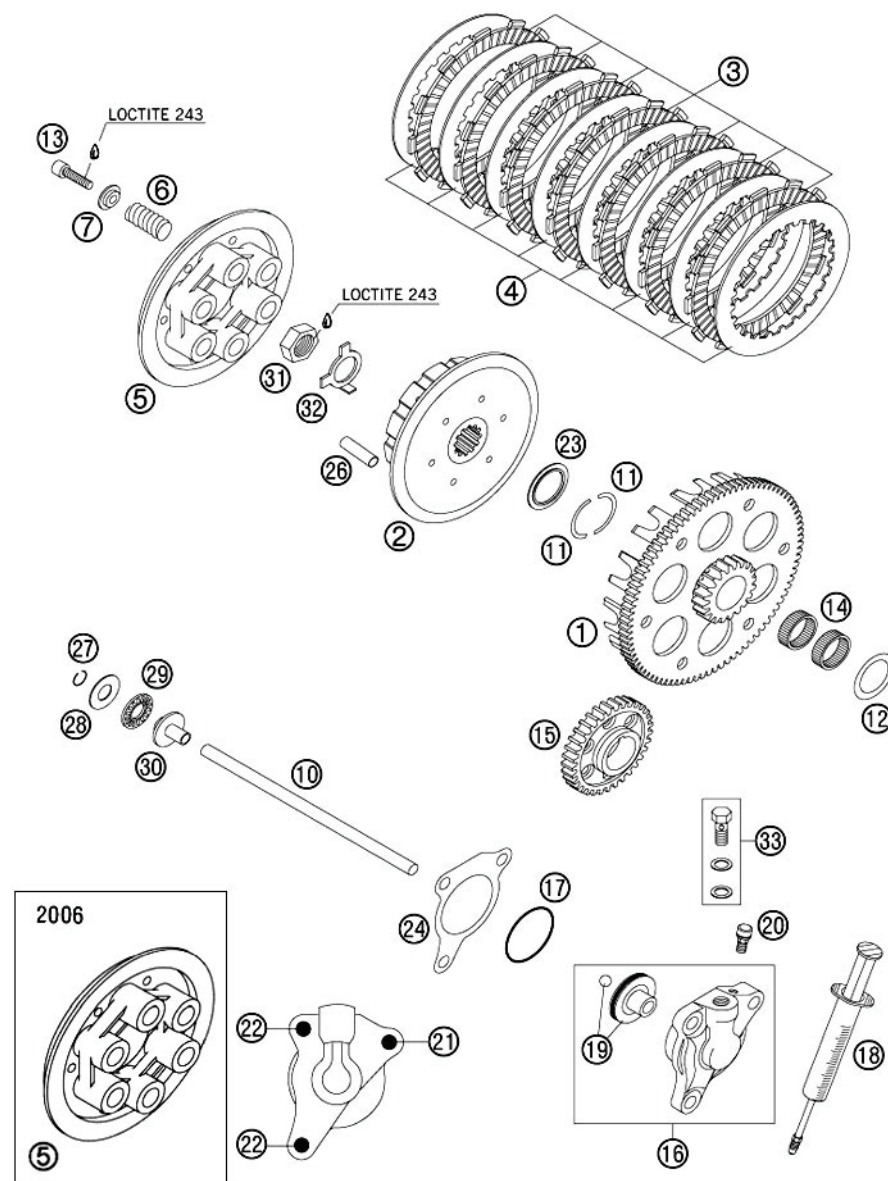

TAV.16A

Pos Loc Pos Ps Pos	Numero Number Numéro Número Nummer	Nota Note Note Nota Anm.	Descrizione	Description	Désignation	Beschreibung	Descripción
1	3625258 000		Frizione Esterna	Outer Clutch	Embrayage Exterieur	Kupplungskorb 76-Z/20-Z Einsatz Gehärtet	Embrague Exterior
1	3625464 000	2006	Frizione Esterna	Outer Clutch	Embrayage Exterieur	Kupplungskorb 76-Z/20-Z Einsatz Gehärtet	Embrague Exterior
2	3625259 000		Mozzo Interno Frizione	Inner Clutch Hub	Moyeu Interieur Embrayage	Mitnehmer	Buje Interior Embrague
2	3625451 000	2006	Mozzo Interno Frizione	Inner Clutch Hub	Moyeu Interieur Embrayage	Mitnehmer	Buje Interior Embrague
3	3625267 000		Disco Frizione 2mm	Lining Disc 2mm	Disque Embrayage 2mm	Belaglamelle 2mm	Disque Embrague 2mm
4	3625266 000		Disco Frizione Intermedio 1mm	Intermediate Disc 1mm	Disque Embrayage 1mm	Zwischenlamelle 1mm	Disque Embrague 1mm
5	3625260 000		Coperchio A Pres.Frizione Con Pas. Olio	Pressure Cap W. Oil Passage	Couvercle Embrayage	Druckkappe M.Ölbohrungen	Tapa Embrague
5	3625452 000	2006	Coperchio A Pres.Frizione Con Pas. Olio	Pressure Cap W. Oil Passage	Couvercle Embrayage	Druckkappe M.Ölbohrungen	Tapa Embrague
6	3625262 000		Molla Frizione 2,5x43mm	Clutch Spring 2,5x43mm	Ressort Embrayage 2,5x43mm	Kupplungsfeder 2,5x43mm	Muelle Embrague 2,5x43mm
7	3625263 000		Reggimolla Frizione 6,2x12x18x3,6mm	Spring Retainer 6,2x12x18x3,6mm	Porte-Ressort Embrayage 6,2x12x18x3,6 Mm	Federteller 6,2x12x18x3,6	Muelle Embrague 6,2x12x18x3,6 Mm
7	3625453 000	2006	Reggimolla Frizione 6,2x12x18x5,2mm	Spring Retainer 6,2x12x18x5,2mm	Porte-Ressort Embrayage 6,2x12x18x5,2 Mm	Federteller 6,2x12x18x5,2	Muelle Embrague 6,2x12x18x5,2 Mm
8	3625454 000	2006	Disco Intermedio 1,4mm	Intermediate Plate 1.4mm	Disque Intermediaire 1,4mm	Mittlere Scheibe 1,4mm	Disco Intermedio 1,4mm
10	3625269 000		Asta Spingidisco Frizione 7x188mm	Push Rod 7x188mm	Etrier Disque Embrayage 7x188mm	Druckstnge 7x189,6mm	Asta Disque Embrague 7x189,6mm
10	3625455 000	2006	Asta Spingidisco Frizione 7x189,6mm	Push Rod 7x189,6mm	Etrier Disque Embrayage 7x189,6mm	Druckstnge 7x188mm	Asta Disque Embrague 7x188mm
11	3625264 000		Rondella (Mezza)	Push Rod 7x188mm	Rondelle	Halbscheibe	Arandela
12	3625268 000		Rondella Di Supporto 25x35x1	Supportwasher 25x35x1	Rondelle 25x35x1	Stützscheibe 25x35x1	Arandela Soporte 25x35x1
13	3625073 000		Vite M6 X 25	Ah Screw M6 X 25	Vis M6x25	Isk.Schraube M6x25	Tornillo M6x25
14	3625029 000		Gabbia A Rulli 25x29x10	Needle Bear K 25x29x10	Cage 25x29x10	Nadelkranz K25x29x10	Jaula 25x29x10
15	3625257 000		Ingranaggio Primario 33 T	Primary Gear 33 T	Engranaage Primaire 33t	Primärrad 33-Z	Engranaaje Primario 33t
16	1291895 033		Corpo Pompa Con Pistone Ø27	Output Cylinder Cpl.	Corps Pompe Avec Pist.Ø27	Nehmerzylinder Kpl.	Protector Bomba Con Piston Ø27
17	3625058 000		Anello Or 30,00x1,50 Nbr 70	O-Ring 30,00x1,50 Nbr 70	Or 30,00x1,50 Nbr 70	O-Ring 30,00x1,50	Or 30,00x1,50 Nbr 70
18	3625090 000		Siringa Per Olio Spurgo Frizione	Vent Injektion Hydr. Clutch Frizione	Seringat Huile Embrayage	Entlüft.Spritze Hydr. Kup- plung	Jeringa Aceite Embrague
19	3625272 000		Pistone Con Anello Or Corpo Pompa Friz.	Piston With O-Ring And Ball	Piston Avec Or Pompe Embrayage	Kolben Mit O-Ring Und Kugel	Piston Con Or Cuerpo Bomba Embrague
20	3183530 000		Vite Spec. Pompa Idrraulica Magura	Magura Hydraulic Pump Special Screw	Vis Speciales Pompe Hydraulique Magura	Entlüftungschr. Mit Kappe	Tornillo Espec. Bomba Idrau- lica Magura
21	3625009 000		Bullone 6.35 Rs Ch 8	Bolt 6.35	Boulon 6.35 Rs Ch 8	Sk.Bundschrabe M6x35 Sw=8	Tornillo 6.35 Rs Ch 8

FRIZIONE
CLUTCH
EMBAYAGE
KUPPLUNG
EMBRAGUE

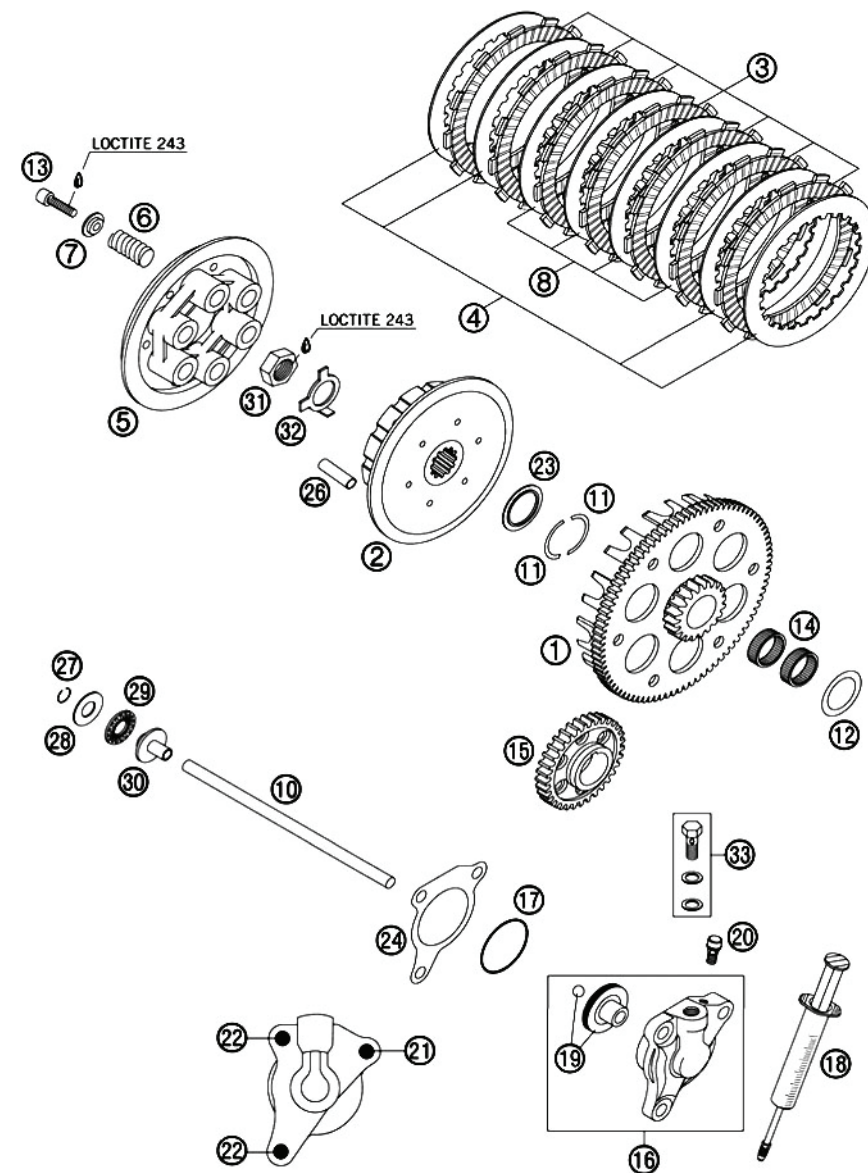

FRIZIONE
CLUTCH
EMBAYAGE
KUPPLUNG
EMBRAGUE

TAV.16A

Pos Loc Pos Ps Pos	Numero Number Numéro Número Nummer	Nota Note Note Nota Anm.	Descrizione	Description	Désignation	Beschreibung	Description
22	1149070 000		Bullone 6.20 Rs Ch 8	Bolt 6.20	Boulon 6.20 Rs Ch 8	Sk.Bundschraube M6x20 Sw=8	Tornillo 6.20 Rs Ch 8
23	3625265 000		Rondella Speciale Con Gradino	Stepped Washer	Rondelle Speciale	Stufenscheibe	Arandela Especial
24	3625271 000		Guarnizione Per Corpo Frizione	Gasket For Slave Cylinder	Joint Corp Embrayage	Dichtung Für Nehmerzylinder	Junta Cuerpo Embrague
26	3625261 000		Perno Guida Frizione	Driving Sleeve D=8, L=31	Pivot Guide Embrayage	Mitnahmhülse D=8,L=31	Eje Guia Embrague
26	3625465 000	2006	Perno Guida Frizione D=8,L=33	Driving Sleeve D=8, L=33	Pivot Guide Embrayage D=8,L=33	Mitnahmhülse D=8,L=33	Eje Guia Embrague D=8,L=33
27	3625079 000		Anello Rw12	Cirdip Rw12	Bague Rw12	Sprengring Rw12	Anillo Rw12
28	3625131 000		Rondella 12x26x1	Axial Washer 12x26x1	Rondelle 12x26x1	Axialscheibe As1226 12x26x1	Arandela 12x26x1
29	3625130 000		Cuscinetto Asta Corpo Frizione	Axial Needle Bearing	Roulement Etrier Embrayage	Axiallager Axk 1226	Cojinete
30	3625092 000		Innesto Asta Corpo Frizione	Pressure Piece	Embrayage Etrier	Druckpilz 125-380	Embrague Asta Cuerpo Embrague
31	3625069 000		Dado M18 X 1,5	Hexagon Nut M18x1,5	Ecrou M18x1,5	Sk.Mutter M18x1,5	Dado M18x1,5
32	3625137 000		Rondella Di Bloccaggio Dado	Lock Washer	Rondelle Blocage Ecrou	Scherungsblech	Arandela Dado
33	3625270 000		Bullone Forato Corpo Frizione	Hollow Screw Hydr. Clutch Cpl.	Boulon Corp Embrayage Cpl.	Hohlschraube Hydr.Kuppl.Kpl.	Tornillo Cuerpo Embrague

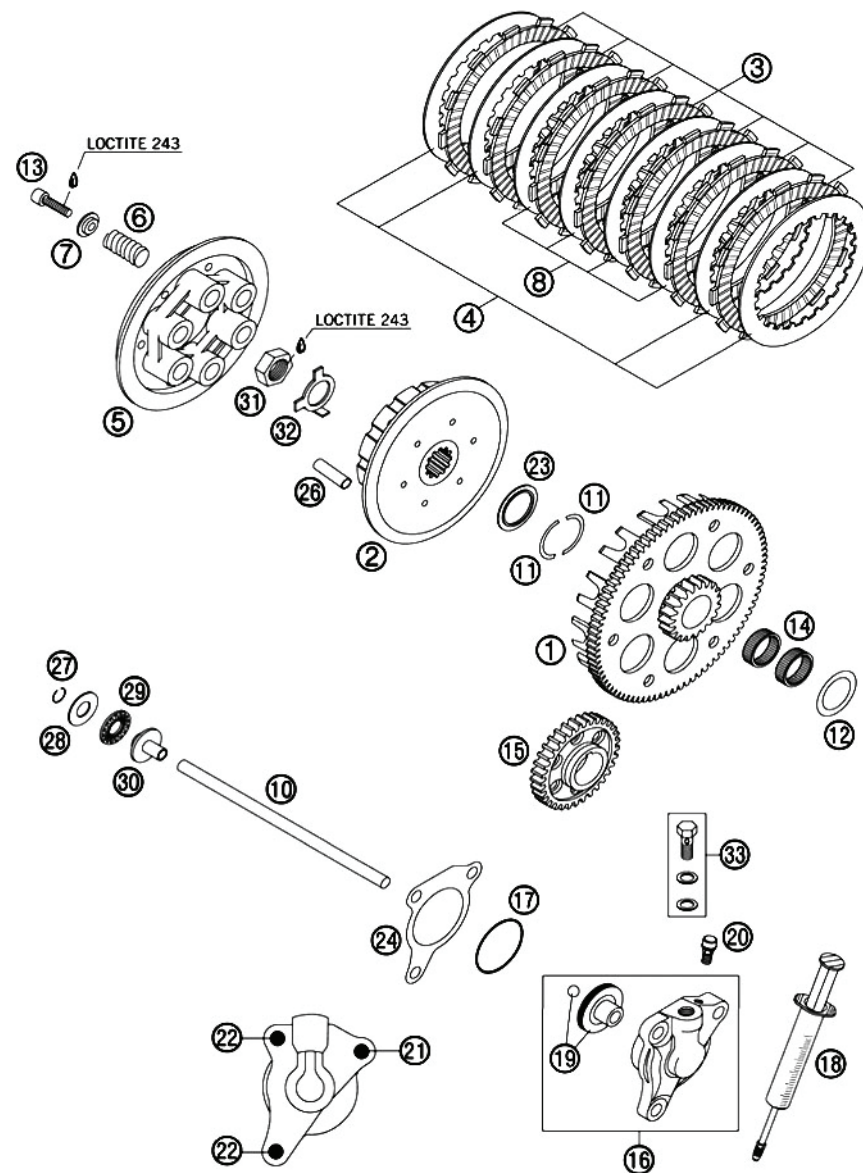

Pos Loc Pos Ps Pos	Numero Number Número Nummer	Nota Note Note Nota Anm.	Descrizione	Description	Désignation	Beschreibung	Descrìption
1	2155620 000		Leva Messa In Moto 250/ 400/450/525 Exc	Kickstarter Lever	Levier Demarrage 250/ 400/450/525 Exc	Kickstarter Kpl	Palanca Arranque 250/ 400/450/525 Exc
2	1170014 000		Bullone Spec. Leva Mm Rr 4t	Special Bolt, Rr 4t	Boulon Spec. Levier Demar- rage Rr4t	Kettenradschr. M8x20 Isk Sw=6	Tornillo Espec. Palanca Arranque Rr 4t
3	2774788 000		Rondella Speciale Fis.Gio Leva Mm Rr4t	Washer	Rondelle Spec. Fixage Levier Dem. Rr4t	Fasonscheibe 8mm Verzinkt	Arandela Espec. Fijacion Pal- anca Arranque Rr4t
4	3625045 000		Anello Paraolio 19x30x7	Shaft Seal Ring 19x30x7	Joint Spy 19x30x7	Wellendichtring 19x30x7	Junta Aceite 19x30x7
5	3625293 000		Mozzo Guida Messa In Moto	Driving Hub	Moyeu Guide Demarrage	Mitnehmernabe	Buje Gujia Arranque
6	3625289 000		Ingranaggio Messa In Moto	Kickstarter Gear 39-T	Engranage Demarrage	Starterrad 39-Z	Engranaje Arranque
7	3625031 000		Anello 17 X 1	Circlip 17 X 1	Bague 17x1	Sicherungsring 17x1	Anillo 17x1
9	3625078 000		Rondella 17x24x0,5	Shim Washer 17x24x0,5	Rondelle 17x24x0,5	Passscheibe 17x24x0,5	Arandela 17x24x0,5
10	3625291 000		Ingranaggio Intermedio Messa In Moto Z24	Intermediate Gear 24-T	Engranage Demarrage Z24	Starterzwischenrad 24-Z	Engranaje Arranque Z24
12	3625292 000		Molla Messa In Moto	Kickstarter Spring	Ressort Demarrage	Kickstarfeder	Nuelle Arranque
13	3625295 000		Piastrina Attacco Molla Messa In Moto	Spring Hanger	Plaquette Ressort Demar- rage	Federlasche	Placa Muelle Arranque
14	1147015 000		Bullone 6.12 Rs Ch 8	Bolt 6.12	Boulon 6.12 Rs Cle' 8	Sk.Bundsraube M6x12 Sw=8	Tornillo 6.12 Rs Ch 8
15	3625296 000		Rondella Spessore 20x32x1	Shim 20x32x1	Rondelle Epaisseur 20x32x1	Scheibe 20x32x1	Arandela Espesor 20x32x1
16	3625032 000		Anello 19 X 1,2	Circlip 19 X 1,2	Bague 19x1,2	Sicherungsring 19x1,2	Anillo 19x1,2
17	3625026 000		Gabbia A Rulli 22x26x10	Needle Bearing K 22x26x10	Cage 22x26x10	Nadelkranz K 22x26x10 A	Jaula 22x26x10
18	3625294 000		Battuta Messa In Moto	Bump Part	Battue Demarrage	Anschlagstück	Paliza Arranque
19	3625181 000		Rondella Di Fissaggio 22,2x30x1,5	Stop Disk 22,2x30x1,5	Rondelle Fixage 22,2x30x1,5	Anlaufscheibe 22,2 X 30 X 1,5	Arandela Fijacion 22,2x30x1,5
20	3625180 000		Molla Nottolino Arresto Ingr./Alberomm	Ratchet Gear Spring 1,2 Mm	Ressort Cliquet	Sperrradfeder 1,2 Mm	Muelle Engranaje/Ciguenal Arranque
21	3625290 000		Nottolino Arresto Ingr./ Albero Mm	Kickstarter Sleeve	Douille Demarrage	Kickstarter Muffe	Manguito Arranque
23	1149070 000		Bullone 6.20 Rs Ch 8	Bolt 6.20	Boulon 6.20 Rs Ch 8	Sk.Bundsraube M6x20 Sw=8	Tornillo 6.20 Rs Ch 8
24	3625288 000		Albero Messa In Moto	Kickstarter Shaft	Arbre Demarrage	Kickstarterwelle	Arbre Arranque

LEVA MESSA IN MOTO
KICKSTARTER
DEMARRAGE
KICKSTARTER
ARRAQUE

250-400-450-525CC / 2005-2006

TAV.17

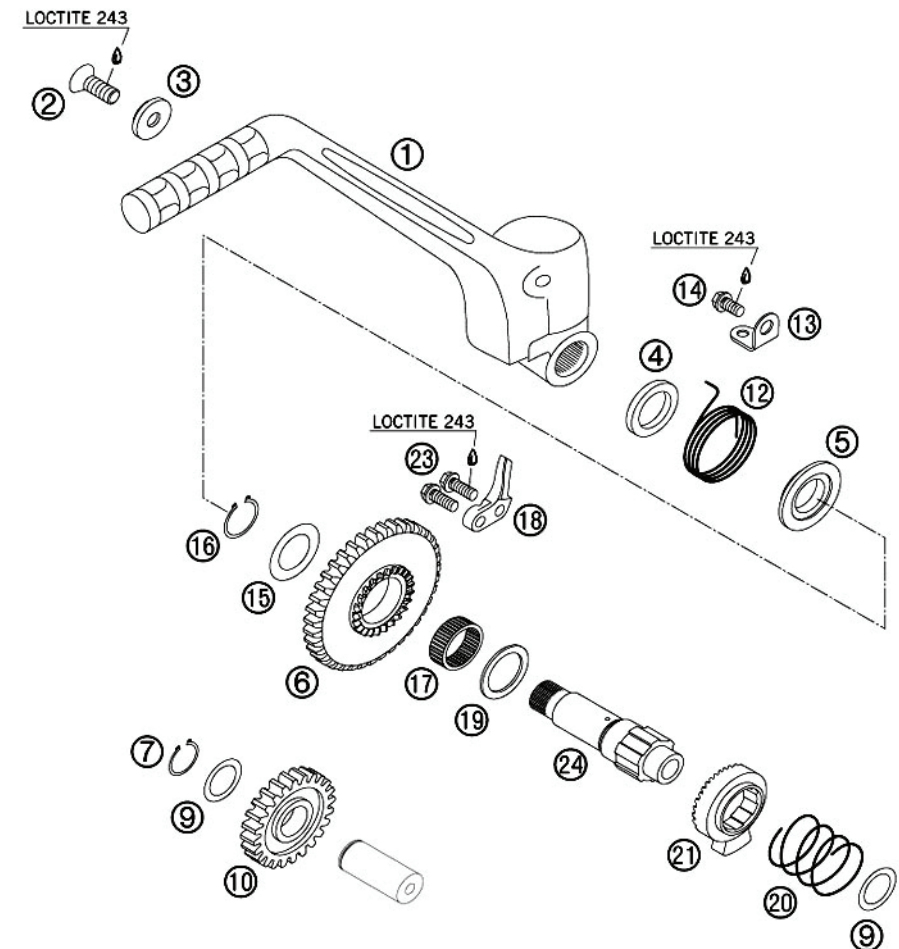

Pos Loc Pos Ps Pos	Numero Number Numéro Número Nummer	Nota Note Note Nota Anm.	Descrizione	Description	Désignation	Beschreibung	Descripción
1	3625393 000		Albero Z.14 Trasmissione Primaria	Main Shaft 14-T, Primary Transmission	Arbre Z.14 Transmission Primaire	Antriebswelle 14-Z	Ciguenal Z.14 Transmission Primaria
2	3625396 000		Ingranaggio 5ø Albero Primario	Idler Gear 5.G Z.23	Engranaaje 5ø Arbre Primaire	Losrad 5.G 23-Z	Engranaaje 5 Ciguenal Primario
3	3625093 000		Boccola Ingr. 5ø Albero Primario	Idler Gear Bush 22x25x11,1	Bague Engr. 5ø Arbre Primaire	Losradbüchse 22x25x11,1	Anillo Engranaaje 5 Ciguenal Primario
4	3625096 000		Rondella Spec.Fis.Ingr.Interm.Alb.Prim	Stop Disk 22,2x27,8x1	Rondelle Spec.Fix.Engr.Interm.Arbre Prim	Anlaufscheibe 22,2x27,8x1	Arandela Espec. Fijacion Engranaaje Interm. Cg. P.
5	3625395 000		Ingranaggio 3ø/4ø Z.19/21 Su Primario	Sliding Gear 3./4.G 19/21-T	Engranaaje 3ø/4ø Z.19/21 Sur Primaire	Schieberad 3./4.G 19/21-Z	Engranaaje 3/4 Z.19/21 Sobre Primario
6	3625089 000		Anello 22 X 1,2	Lock Ring 22x1,2	Bague 22x1,2	Sprengring 22x1,2	Anillo 22x1,2
7	3625095 000		Rondella Spec.Fis.Ingr.3ø/4ø Alb. Prim.	Stop Disk 22,2x27,8x1a	Rondelle Spec.Fix.Engr.3/4 Arbr. Prim	Anlaufscheibe 22,2x27,8x1	Arandela Espec. Fijacion Engranaaje 3/4 Cig. Pri.
9	3625397 000		Ingranaggio 6ø Z.22 Su Primario	Idler Gear 6.G 22-T	Engranaaje 6ø Z.22 Sur Primaire	Losrad 6.Gang 22-Z	Engranaaje 6 Z.22 Sobre Primario
10	3625394 000		Ingranaggio 2ø Z.16 Su Primario	Solid Gear 2.G 16-T	Engranaaje 2ø Z.16 Sur Primaire	Festrad 2.Gang 16-Z	Engranaaje 2° Z.16 Sobre Primario
11	3625094 000		Rondella Spec.Fis.Ingr.2ø Alb. Prim.	Stop Disk 17,2x24x1	Rondelle Spec. Fix. Engr. 2ø Arbre Prim.	Anlaufscheibe 17,2x24x1	Arandela Espec. Fijacion Engranaaje 2° Cig. Pri.
12	3625039 000		Cuscinetto A Sfere 6203	Ball. Bearing 6203	Roulement 6203	Rillenkugellager 6203 Jr2 C3	Cojinete 6203
13	3625040 000		Cuscinetto A Sfere 6205	Ball. Bearing 6205	Roulement	Rillenkugellager 6205 C3 Ntn	Cojinete 6205

**TRASMISSIONE PRIMARIA
TRANSMISSION 1° - MAIN SHAFT
TRANSMISSION PRIMAIRE
GETRIEBE 1° - ANTRIEBSWELLE
TRANSMISSION 1°**

250CC / 2005-2006

TAV.18

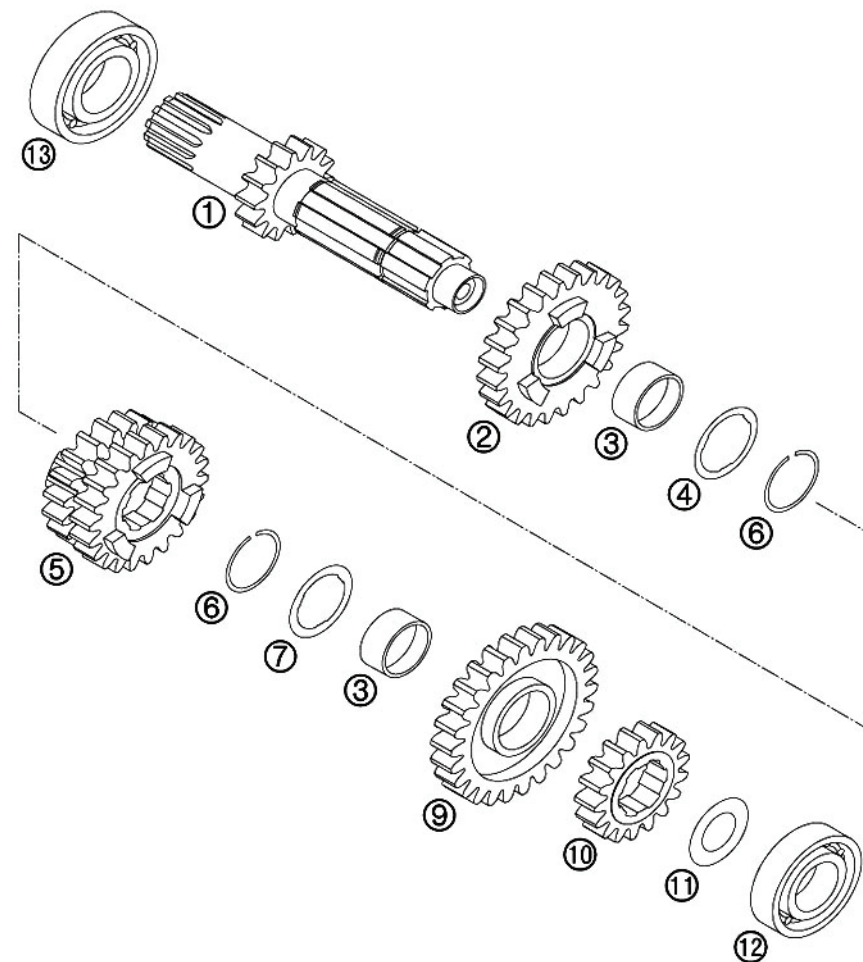

Pos Loc Pos Ps Pos	Numero Number Número Número	Nota Note Note Nota Anm.	Descrizione	Description	Désignation	Beschreibung	Description
1	3625273 000		Albero Z.14 Trsm. Primaria 400/450/525	Main Shaft, Prim. Transmission 400/450/525	Arbre Z.14 Transm. Primaire 400/450/525	Antriebswelle - Zb 14-Z	Arbre Z.14 Transmission Primaire 400/450/525
2	3625276 000		Ingranaggio 5a Z.24 400/450/525	Idler Gear 5.G 24-T	Engrange 5a Z.24 400/450/525	Losrad 5.G 24-Z 34	Engraje 5° Z.24 400/450/525
3	3625028 000		Boccola Ingr. 5a Su Albero Primario	Needle Bear K 22x26x13	Bague Engrange 5a Sur Vilebrequin	Nadelkranz K 22x26x13 Tn	Anillo
4	3625286 000		Rondella Spec. 25,2x32x1,5	Stop Disk 25,2x32x1,5	Rondelle Spec. 25,2x32x1,5	Anlaufscheibe 25,2x32x1,5	Arandela Especial 25,2x32x1,5
5	3625275 000		Ingranaggio 3a/4a Z.19/22 Su Primario	Sliding Gear 3./4.G 19/22-T	Engrange 3a/4a Z.19/22 Sur Primaire	Schieberad 3./4.G 19/22-Z 32	Engraje 3/4 Z.19/22 Sobre Primario
6	3625033 000		Anello 25 X 1,2	Circlip 25x1,2	Bague 25x1,2	Sicherungsring 25x1,2	Anillo 25x1,2
7	3625285 000		Rondella Spec.Fis.Ingr.3a/4a Alb. Prim.	Stop Disk 25,2x32x1,5	Rondelle Spec. Fix. Engr. 3/4	Anlaufscheibe 25,2x32x1,5	Arandela Especial Fijacion
9	3625277 000		Ingranaggio 6a Z.26 Su Primario	Idler Gear 6.G 26-T	Engrange 6a Z.26 Sur Primaire	Losrad 6.Gg 26-Z 35	Engraje 6° Z.26 Sobre Primario
10	3625274 000		Ingranaggio 2a Z.17 Su Primario	Solid Gear 2.G 17-T	Engrange 2a Z.17 Sur Primaire	Festrad 2.G 17-Z 21	Engraje 2° Z.17 Sobre Primario
11	3625136 000		Rondella Spec. 17,2x30x1	Stop Disk 17,2x30x1	Rondelle Spec. 17,2x30x1	Anlaufscheibe 17,2x30x1	Arandela 17,2x30x1
12	3625039 000		Cuscinetto A Sfere 6203	Ball. Bearing 6203	Roulement 6203	Rillenkugellager 6203 Jr2 C3	Cojinete 6203
13	3625040 000		Cuscinetto A Sfere 6205	Ball. Bearing 6205	Roulement	Rillenkugellager 6205 C3 Ntn	Cojinete 6205

TRASMISSIONE PRIMARIA
TRANSMISSION PRIMAIRE
GETRIEBE 1° - ANTRIEBSWELLE
TRANSMISSION 1°

400-450-525CC / 2005-2006

TAV.19

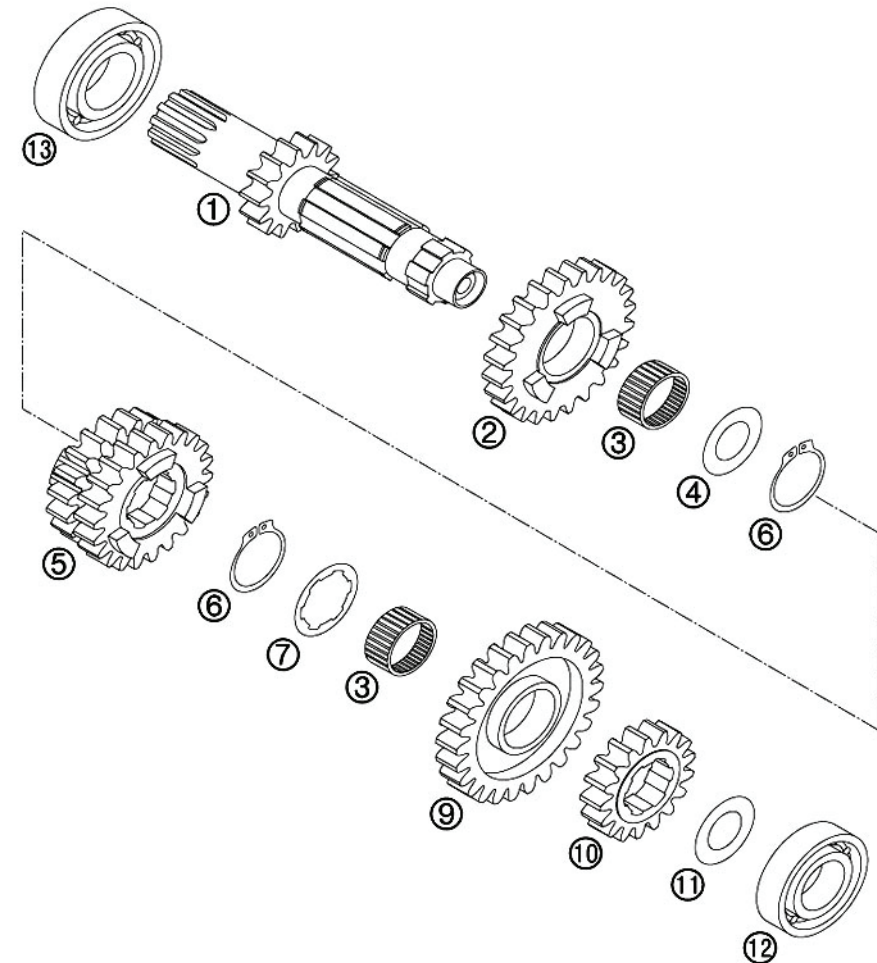

Pos Loc Pos Ps Pos	Numero Number Número Número Nummer	Nota Note Note Nota Anm.	Descrizione	Description	Désignation	Beschreibung	Descrìption
1	3625278 000		Albero Trasmissione Secondaria	Main Shaft, Secondary Transmission	Arbre Cable Secondaire	Abtriebswelle	Arbre Transmission Secondaria
2	3625399 000		Ingranaggio 2ø Z.36 Su Secondario	Idler Gear 2. Gear 36-T	Engranage 2ø Z.36 Sur Secondaire	Losrad 2.Gang 36-Z	Engraje 2 Z.36 Sobre Secundario
3	3625027 000		Gabbia A Rulli 22x26x10	Needle Bear.K 22x26x10	Cage 22x26x10	Nadelkranz K 22x26x10 Geteilt	Jaula 22x26x10
4	3625286 000		Rondella Spec. 25,2x32x1,5	Stop Disk 25,2x32x1,5	Rondelle Spec. 25,2x32x1,5	Anlaufscheibe 25,2x32x1,5	Arandela Especial 25,2x32x1,5
5	3625033 000		Anello 25 X 1,2	Grclip 25x1,2	Bague 25x1,2	Sicherungsring 25x1,2	Anillo 25x1,2
6	3625403 000		Ingranaggio 6ø Z.25 Su Secondario	Sliding Gear 6. Gear 25-T	Engranage 6ø Z.25 Sur Secondaire	Schieberad 6.Gang 25-Z	Engraje 6 Z.25 Sobre Secundario
9	3625401 000		Ingranaggio 4ø Z.32 Su Secondario	Sliding Gear 4. Gear 32-T	Engranage 4ø Z.32 Sur Secondaire	Losrad 4.Gang 32-Z	Engraje 4.Z.32 Sobre Secundario
10	3625400 000		Ingranaggio 3ø Z.34 Su Secondario	Sliding Gear 3. Gear 34-T	Engranage 3ø Z.34 Sur Secondaire	Losrad 3.Gang 34-Z	Engraje 3 Z.34 Sobre Secundario
13	3625402 000		Ingranaggio 5ø Z.30 Su Secondario	Sliding Gear 5. Gear 30-T	Engranage 5ø Z.30 Sur Secondaire	Schieberad 5.Gang 30-Z	Engraje 5 Z.30 Sobre Secundario
14	3625296 000		Rondella Spessore 20x32x1	Shim 20x32x1	Rondelle Epaisseur 20x32x1	Scheibe 20x32x1	Arandela Espesor 20x32x1
15	3625025 000		Gabbia A Rulli 20x26x12	Needle Bear.K 22x26x12	Cage 20x26x12	Nadelkranz K 20x26x12	Jaula 20x26x12
16	3625398 000		Ingranaggio 1ø Z.38 Su Secondario	Idler Gear 1. Gear 38-T	Engranage 1ø Z.38 Sur Secondaire	Losrad 1.Gang 38-Z	Engraje 1 Z.38 Sobre Secundario
17	3625136 000		Rondella Spec. 17,2x30x1	Stop Disk 17,2x30x1	Rondelle Spec. 17,2x30x1	Anlaufscheibe 17,2x30x1	Arandela 17,2x30x1
18	3625121 000		Boccola Distanziale 12mm	Spacer Bushing 12mm	Bague Entratoise 12mm	Distanzbüchse 12mm	Anillo Distanciador 12mm
20	2564079 000		Pignone Z.14 5/8 1/4 Rr 4t	Sproket, Chain Z.14 5/8 1/4 Rr 4t	Pignon Z.14 5/8 1/4 Rr 4t	Kettenrad 14-Z	Pignon Z.14 5/8 1/4 Rr4t
20	2564081 000		Pignone Z.15 5/8 1/4 Rr 4t	Sproket, Chain Z.15 5/8 1/4 Rr 4t	Pignon Z.15 5/8 1/4 Rr4t	Kettenrad 15-Z	Pignon Z.15 5/8 1/4 Rr4t
20	3625088 000		Pignone Z.13	Sprocket 13-T	Pignon Z.13	Kettenrad 13-Z	Pinon Z.13
22A	1170013 000		Bullone Spec. M10x18 Fis. Pignone Rr4t	Special Bolt, Rr 4t	Boulon Spec. M10x1 Fix. Pignon Rr4t	Sk.Bundschraube	Tornillo Espec. M10x18 Fij.Pignon Rr4t
22B	2774787 000		Rondella Speciale Fis.Gio Pignone Rr4t	Washer	Rondelle Spec. Fixage Pignon Rr4t	Passscheibe	Arandela Espec. Fijacion Pinon Rr4t
22	3625287 000		Vite Con Molla A Tazza Fissaggio Pignone	Screw+Spring Washer	Vis A/Ressort Fixage Pignon	Schraube + Tellerfeder	Tornillo Muelle Fijacion Pignon
25	3625049 000		Anello Or 25,12x1,78 Nbr 70	O Ring 25,12x1,78 Nbr 70	Or 25,12x1,78 Nbr 70	O-Ring 25,12x1,78	Or 25,12x1,78 Nbr 70
30	3625039 000		Cuscinetto A Sfere 6203	Ball. Bearing 6203	Roulement 6203	Rillenkugellager 6203 Jr2 C3	Cojinete 6203
31	3625086 000		Cuscinetto A Sfere 6203	Ball Bearing 6203	Roulement 6203	Zilinderrollenlag. Ni205	Cojinete 6203
32	3625047 000		Anello Paraolio 32x45x7 Nbr	Shaft Seal Ring 32x45x7 Bsl Nbr	Joint Spy 32x45x7	Wellendichtring 32x45x7	Junta Aceite 32x45x7

TRASMISSIONE SECONDARIA
TRANSMISSION II° - MAIN SHAFT
TRANSMISSION SECONDAIRE
GETRIEBE II° - ANTRIEBSWELLE
TRANSMISSION II°

250CC / 2005-2006

TAV.20

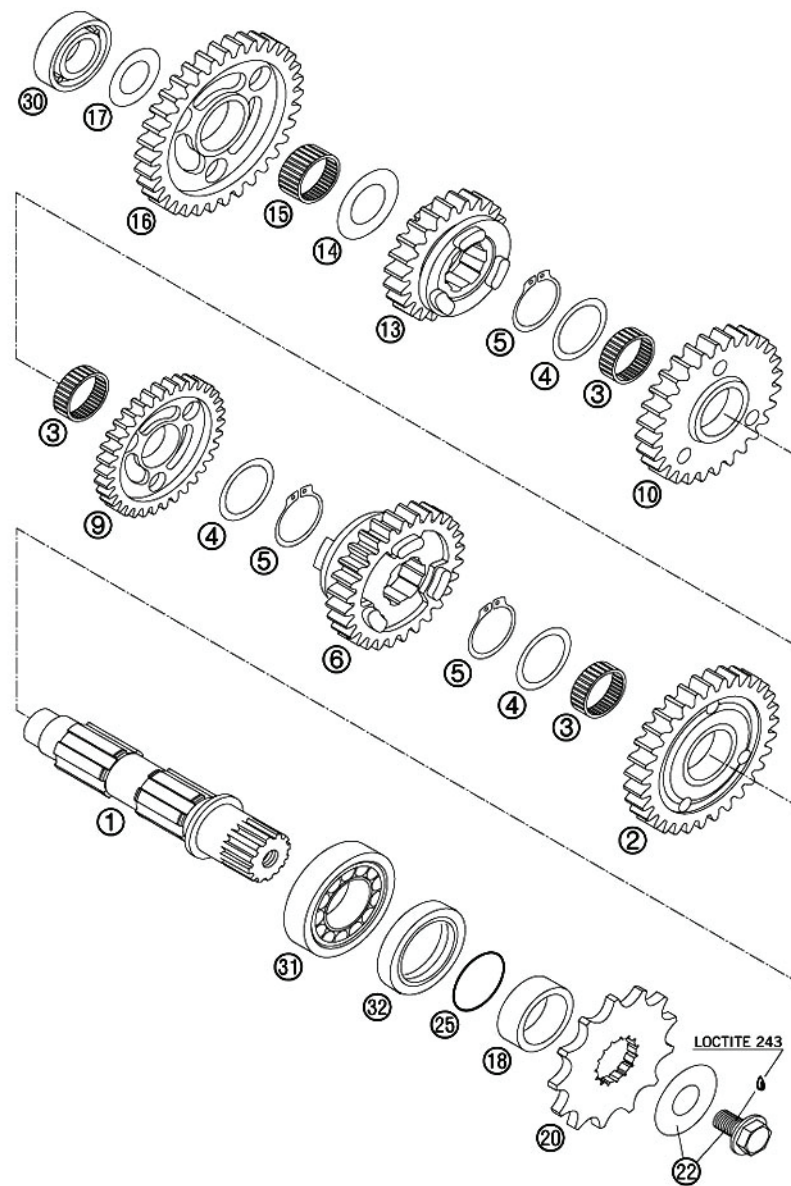

Pos Loc Pos Ps Pos	Numero Number Número Número Nummer	Nota Note Note Nota Anm.	Descrizione	Description	Désignation	Beschreibung	Descrìption
1	3625278 000		Albero Trasmissione Secondaria	Main Shaft, Secondary Transmission	Arbre Cable Secondaire	Abtriebswelle	Arbre Transmission Secondaria
2	3625280 000		Ingranaggio 2ø Z.31 Su Secondario	Idler Gear 2. Gear 31-T	Engranage 2ø Z.31 Sur Secondaire	Losrad 2.G 31-Z 25	Engranaje 2° Z.31 Sobre Secundario
3	3625027 000		Gabbia A Rulli 22x26x10	Needle Bear.K 22x26x10	Cage 22x26x10	Nadelkranz K 22x26x10 Geteilt	Jaula 22x26x10
4	3625286 000		Rondella Spec. 25,2x32x1,5	Stop Disk 25,2x32x1,5	Rondelle Spec. 25,2x32x1,5	Anlaufscheibe 25,2x32x1,5	Arandela Especial 25,2x32x1,5
5	3625033 000		Anello 25 X 1,2	Grclip 25x1,2	Bague 25x1,2	Sicherungsring 25x1,2	Anillo 25x1,2
6	3625284 000		Ingranaggio 6ø Z.21 Su Secondario	Idler Gear 6. Gear 21-T	Engranage 6ø Z.21 Sur Secondaire	Schieberad 6.G 21-Z 26	Engranaje 6° Z.21 Sobre Secundario
8	3625285 000		Rondella Spec.Fis.Ingr.3ø/4ø Alb. Prim.	Stop Disk 25,2x32x1,5	Rondelle Spec. Fix. Engr. 3/4 Arbre Pr	Anlaufscheibe 25,2x32x1,5	Arandela Especial Fijacion Engranaje 3/4 Arbre
9	3625282 000		Ingranaggio 4ø Z.26 Su Secondario	Sliding Gear 4. Gear 26-T	Engranage 4ø Z.26 Sur Secondaire	Losrad 4.G 26-Z 33	Engranaje 4° Z.26 Sobre Secundario
10	3625281 000		Ingranaggio 3ø Z.28 Su Secondario	Sliding Gear 3. Gear 28-T	Engranage 3ø Z.28 Sur Secondaire	Losrad 3.G 28-Z 28	Engranaje 3° Z.28 Sobre Secundario
13	3625283 000		Ingranaggio 5ø Z.23 Su Secondario	Sliding Gear 5. Gear 23-T	Engranage 5ø Z.23 Sur Secondaire	Schieberad 5.G 23-Z 29	Engranaje 5° Z.23 Sobre Secundario
14	3625296 000		Rondella Spessore 20x32x1	Shim 20x32x1	Rondelle Epaisseur 20x32x1	Scheibe 20x32x1	Arandela Espesor 20x32x1
15	3625025 000		Gabbia A Rulli 20x26x12	Needle Bear.K 20x26x12	Cage 20x26x12	Nadelkranz K 20x26x12	Jaula 20x26x12
16	3625279 000		Ingranaggio 1ø Z.34 Su Secondario	Idler Gear 1. Gear 34-T	Engranage 1ø Z.34 Sur Secondaire	Losrad 1.G 34-Z 30	Engranaje 1° Z.34 Sobre Secundario
17	3625136 000		Rondella Spec. 17,2x30x1	Stop Disk 17,2x30x1	Rondelle Spec. 17,2x30x1	Anlaufscheibe 17,2x30x1	Arandela 17,2x30x1
18	3625121 000		Boccola Distanziale 12mm	Spacer Bushing 12mm	Bague Entratoise 12mm	Distanzbüchse 12mm	Anillo Distanciador 12mm
20	2564079 000		Pignone Z.14 5/8 1/4 Rr 4t	Sproket, Chain Z.14 5/8 1/4 Rr 4t	Pignon Z.14 5/8 1/4 Rr 4t	Kettenrad 14-Z	Pignon Z.14 5/8 1/4 Rr4t
20	2564081 000		Pignone Z.15 5/8 1/4 Rr 4t	Sproket, Chain Z.15 5/8 1/4 Rr 4t	Pignon Z.15 5/8 1/4 Rr4t	Kettenrad 15-Z	Pignon Z.15 5/8 1/4 Rr4t
20	3625088 000		Pignone Z.13	Sprocket 13-T	Pignon Z.13	Kettenrad 13-Z	Pinon Z.13
22A	1170013 000		Bullone Spec. M10x18 Fis. Pignone Rr4t	Special Bolt, Rr 4t	Boulon Spec. M10x1 Fix. Pignon Rr4t	Sk.Bundschraube	Tornillo Espec. M10x18 Fij.Pignon Rr4t
22B	2774787 000		Rondella Speciale Fis.Gio Pignone Rr4t	Washer	Rondelle Spec. Fixage Pignon Rr4t	Passscheibe	Arandela Espec. Fijacion Pinon Rr4t
22	3625287 000		Vite Con Molla A Tazza Fissaggio Pignone	Screw+Spring Washer	Vis A/Ressort Fixage Pignon	Schraube + Tellerfeder	Tornillo Muelle Fijacion Pignon
25	3625049 000		Anello Or 25,12x1,78 Nbr70	O Ring 25,12x1,78 Nbr70	Or 25,12x1,78 Nbr 70	O-Ring 25,12x1,78	Or 25,12x1,78 Nbr 70
30	3625039 000		Cuscinetto A Sfere 6203	Ball. Bearing 6203	Roulement 6203	Rillenkugellager 6203 Jr2 C3	Cojinete 6203
31	3625086 000		Cuscinetto A Sfere 6203	Ball Bearing 6203	Roulement 6203	Zilinderrollenlag. Nj205	Cojinete 6203
32	3625047 000		Anello Paraolio 32x45x7 Nbr	Shaft Seal Ring 32x45x7 Bsl Nbr	Joint Spy 32x45x7	Wellendichtring 32x45x7	Junta Aceite 32x45x7

TRASMISSIONE SECONDARIA
TRANSMISSION II° - MAIN SHAFT
TRANSMISSION SECONDAIRE
GETRIEBE II° - ANTRIEBSWELLE
TRANSMISSION II°

400-450-525CC / 2005-2006

TAV.21

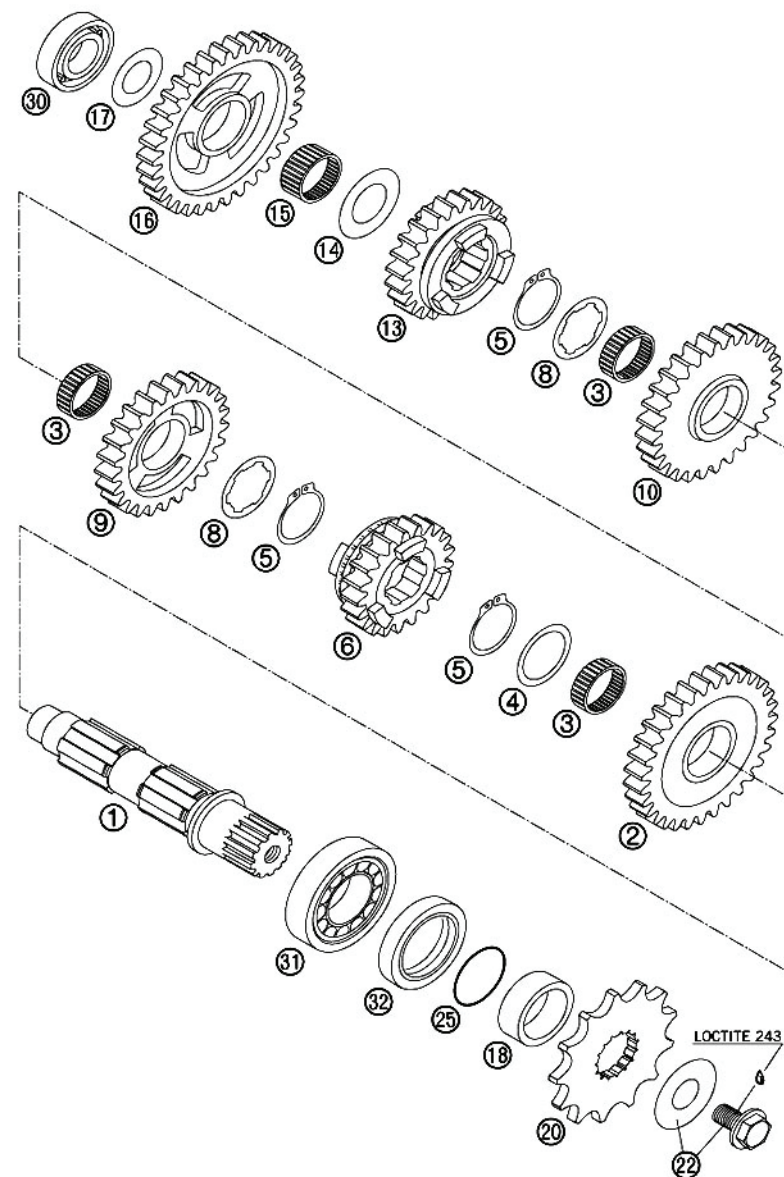

Pos Loc Pos Ps Pos	Numero Number Número Número Nummer	Nota Note Note Nota Anm.	Descrizione	Description	Désignation	Beschreibung	Descrìption
1	3625307 000		Leva Comando Cambio Cpl.	Shifting Lever Cpl.	Lever Selecteur De Vitesse	Schalthebel Kpl.	Palanca Mando Cambio
2	3625068 000		Bullone M6 X 16 10.9	Hh Screw M6 X 16 10.9	Boulon M6x16 10.9	Sk.Schraube M6x16 10.9	Tornillo M6x16 10.9
3	1346492 000		Distanziale 6,4.17.3 (Ktm)	Spacer, 6,4.17.3	Entretoise 6,4.17.3	Stahlscheibe 6,4x17x3	Distanciador 6,4.17.3
4	3625044 000		Anello Paraolio 14x24x6	Shaft Seal Ring 14x24x6 B	Joint Spy 14x24x6	Wellendichtung 14x24x6 B	Junta Aceite 14x24x6
5	3625120 000		Gabbia A Rulli 14,6x20x12	Needle Bear.K 14,6x20x12	Cage 14,6x20x12	Nedelhülse Hk 1412 14,6x20x12	Jaula 14,6x20x12
6	3625298 000		Forchetta Selezione 2ø/4ø	Shift Fork 2./4. Gear	Fourche Selection 2ø/4ø	Schaltgabel 2./4. Gang	Horquilla 2/4
7	3625300 000		Albero Selezione Completo	Shift Shaft Cpl.	Arbre Selection Complet	Schaltwelle Kpl.	Arbre Completo
8	3625299 000		Forchetta Selezione 1ø/3ø 400/450/525	Shift Fork 1./3. Gear, 400/ 450/525	Chape Selection 1ø/3ø 400/ 450/525	Schltgabel 1./3. Gang 400/ 450/525cc	Horquilla 1/3 400/450/ 525
8	3625405 000		Forchetta Selezione 1ø/3ø 250	Shift Fork 1./3. Gear, 250 250	Chape Selection 1ø/3ø 250	Schltgabel 1./3. Gang 250cc	Horquilla 1/3 250cc
9	3625128 000		Rondella 14x30x1	Stop Disk 14x30x1	Rondelle 14x30x1	Anlaufscheibe 14x30x1	Arandela 14x30x1
10	3625125 000		Molla Ritorno 2,2mm	Return Spring 0,8mm	Ressort 2,2mm	Rückholfeder 2,2mm	Nuelle 2,2mm
12	3625138 000		Molla Tensione 0,8mm	Tensioning Spring 0,8mm	Ressort Tensino 0,8mm	Spannerfeder 0,8mm	Muelle 0,8mm
13	3625305 000		Albero Forchette Selezione Cambio	Shift Rail 11,8x105mm	Arbre Vitesses	Schaltschiene Abt. 11,8x105mm	Arbre Horquilla
14	3625188 000		Molla Pressione 0,9mm	Pressure Spring 0,9mm	Ressort Pression 0,9mm	Druckfeder 0,9mm	Muelle Pression 0,9mm
15	1129035 000		Boccola Per Forchette Cr-65/ 2001 - Rr4t	Bush	Douille Pour Fourches Cr- 65/2001	Schaltrolle 6x8x5,2	Anillo Cr-65/2001 - Rr4t
16	3625303 000		Camma Arresto Marce Com- pleta	Shift Lacating Drum Cpl.	Camme Complete	Schaltarretierung Alu Kpl	Camma Completa
17	3625124 000		Ventaglio Albero Comando Cambio Cpl.	Sliding Plate Cpl.	Eventail Arbre Vitesse Cpl.	Gleitblech Kpl.	Abanico Ciguena Mado Cambio Cpl.
18	3625074 000		Bullone M6 X 30	Hh Screw M6 X 30	Boulon M6x30	Isk.Schraube M6x30	Tornillo M6x30
19	3625042 000		Cuscinetto A Sfere 61805 C3	Ball Bearing 61805 C3	Roulement 61805 C3	Rillenkugellager 61805 C3	Cojinete 61805 C3
20	3625127 000		Leva Arresto Marce	Locking Lever Cpl	Lever Arret Vitesses	Arretierhebel Kpl.	Palanca
21	3625006 000		Bullone 5.20 Rs Ch 8	Bolt 5.20	Boulon 5.20 Rs Ch 8	Sk.Bundschrabe M5x20 Sw=8	Tornillo 5.20 Rs Ch 8
22	3625129 000		Distanziale Levetta Arresto Marce	Sleeve For Locking Lever	Entretoise Levier Arret Vitesses	Hülse Für Arretierhebel	Distanciador Palanca
23	3625306 000		Molla Levetta Arresto Marce 2,3mm	Spring For Locking Lever 2,3mm	Ressort Levier Arret Vitesse 2,3mm	Arretierhebelfeder 2,3mm	Muelle Palanca
24	3625304 000		Albero Forchetta 6ø Marcia	Shift Rail 11,8x89mm	Arbre Chape 6ø Vitesse	Schaltschiene Ant. 11,8x89mm	Arbre Horquilla 6°
25	3625297 000		Forchetta Selezione 5ø/6ø 400/450/525	Shift Fork 5./6. Gear 400/ 450/525	Chape Selection 5ø/6ø 400/ 450/525	Schaltgabel 5./6. Gang, 400/450/525cc	Horquilla 5/6 400/450/ 525
25	3625404 000		Forchetta Selezione 5ø/6ø 250cc	Shift Fork 5./6. Gear, 250cc	Chape Selection 5ø/6ø 250cc	Schaltgabel 5./6. Gang, 250cc	Horquilla 5/6 250cc
26	3625301 000		Camma 6 Marce	Shiftroller 6-Gear	Camme	Schaltwalze 6-Gang	Camma 6
27	3625126 000		Guida Molla Comando Cam- bio	Spring Guide	Guide Ressort Commande Vitesse	Federführung	Guia Muelle Mando Cambio

COMANDO CAMBIO
SHIFTING MECHANISM
BOITE A VITESSE
SCHALTUNG
MANDO CAMBIO

250-400-450-525CC / 2005-2006

TAV.22

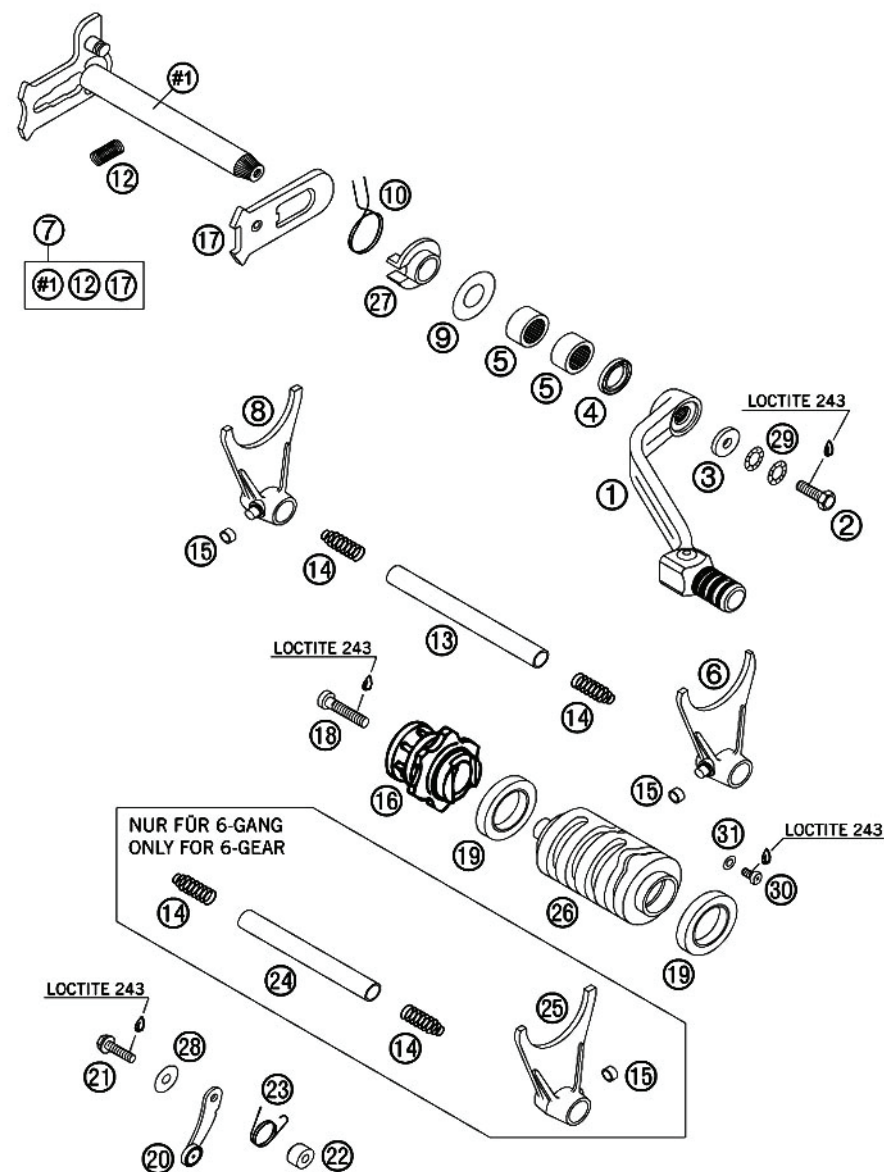

Pos Loc Pos Ps Pos	Numero Number Numéro Número Nummer	Nota Note Note Nota Anm.	Descrizione	Description	Désignation	Beschreibung	Descripción
28	3625018 000		Rondella 5x15x2	Washer 5x15x2	Rondelle 5x15x2	Scheibe 5x15x2	Arandela 5x15x2
29	2739001 000		Rondella 6 Grower (Ktm)	Washer 6	Rondelle 6 Grower	Nordlockscheiben M6 (Paar) Dac	Arandela 6 Grower
30	3625077 000		Bullone M5 X 8	Flat Head Screw M5 X 8	Boulon M5x8	Linsenschraube M5x8	Tornillo M5x8
31	3625015 000		Guarnizione	Washer	Joint	Unterlegscheibe Din 125 A 5,3	Junta

COMANDO CAMBIO
SHIFTING MECHANISM
BOITE A VITESSE
SCHALTUNG
MANDO CAMBIO

250-400-450-525CC / 2005-2006

TAV.22

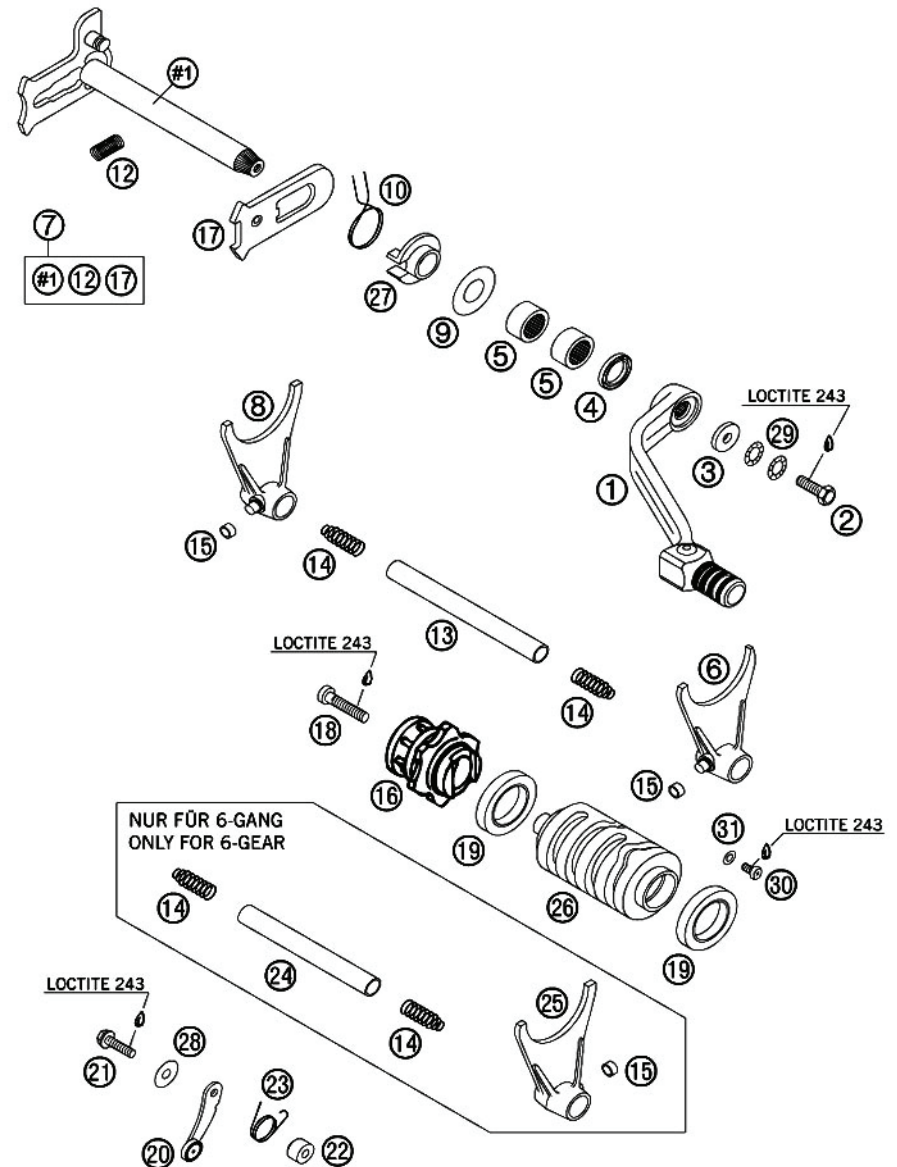

TAV.23

Pos Loc Pos Ps Pos	Numero Number Numéro Número Nummer	Nota Note Note Nota Anm.	Descrizione	Description	Désignation	Beschreibung	Description
1	3625132 000		Attrezzatura Universale Mont.Motore Exc	Universal Mounting Rack '96	Outils Universale Montage Moteur Exc	Universalmontageback	Aparejos Universales Montaje Motor Exc
2	3625198 000		Staffa Supporto Motore Racing	Engine Holder For Racing 2000	Etrier Support Moteur Racing	Motorhalter Für Racing	Abrazadera Soporte Motor Racing
3	3625202 000		Attrezzatura Per Montaggio Maglie Catena	Rivetting Tool Timing Chain	Outils Montage Chaîne	Nietwerkzeug Steuerkette Kpl.	Aparejos Montaje Cadena
4	3625200 000		Attrez.Mont.Anelli Paraolio Pompa Acqua	Mounting Sleeve Seal Ring For Water Pump	Outils Montage Joint Spy Pompe Eau	Montagehülse Wellendichtung F.Wasserpump.Wellendichtung	Aparejos Montaje Juntas Aceite Bomba Agua
5	3625097 000		Pinza Speciale Anelli	Special Circlip Plier	Pince Speciale Bagues	Seegerringzange Verkehrt	Pinza Especial Anillos
6	3625203 000		Estrattore Trasmissione Primaria	Extractor Prim.Gear Cpl.	Extracteur Transmission Primaire	Abzieher Primärrad Kpl.	Extractor Transmisión Primaria
7	3625174 000		Anello Di Compressione X Pistone D=75mm	Piston Ring Compressor D=75mm	Bague Compression Piston D=75mm	Kolben-Montagering D=75mm	Anillo Compresion Piston D=75mm
7	3625175 000		Anello Di Compressione X Pistone D=89mm	Piston Ring Compressor D=89mm	Bague Compr. Piston D=89mm	Kolben-Montagering D=89mm	Anillo Compression Piston D=89mm
7	3625384 000		Anello Di Compressione X Pistone D=95mm	Piston Ring Compressor D=95mm	Bague Piston D=95mm	Kolben-Montagering D=95mm	Anillo De Compression Piston D=95mm
8	3625001 000		Loctite 243 Blu 6ccm	Loctite 243 Blu 6ccm	Loctite 243 Blue 6ccm	Loctite 243 Blau 6ccm	Loctite 243 Blu 6ccm
9	3625081 000		Estrattore Boccole	Bushing Extractor	Extracteur Bagues	Lagerauszieher	Extractor Anillos
10	3625082 000		Estrattore Cuscinetti Interni 12-16mm	Intern. Bear. Puller 12-16mm	Extracteur Roulements Int. 12-16mm	Einsatz 12-16 Mm	Extractor Cojinetes Int. 12-16mm
10	3625083 000		Estrattore Cuscinetti Interni 18-23mm	Intern. Bear. Puller 18-23mm	Extracteur Roulements Int. 18-23mm	Einsatz 18-23 Mm	Extractor Cojinetes Int. 18-23mm
10	3625084 000		Estrattore Cuscinetti Interni 5-7mm	Intern. Bear. Puller 5-7mm	Extracteur Roulements Int. 5-7mm	Einsatz 5-7 Mm	Extractor Cojinetes Int. 5-7mm
11	3625204 000		Attrezzatura Di Verifica Guida Valvole	Limit Plug Gauge F.Valve Guide	Outils Guide Valves	Grenzlehrdorn F.Ventilführung	Aparejos Guja Valvulas
12	3625207 000		Attrez. Montag. Anello Per Friz. Interna	Mounting Ring For Inner Clutch	Outils Montage Bague Embrayage Int.	Montagering Für Mitnehmer	Aparejos Montaje Anillo Embrague Int.
13	3625208 000		Coperchio Di Protezione Albero	Protection Cover F.Main Shaft	Couvercle Protection Arbre	Schutzkappe Für Abtriebswelle	Tapa Protección Arbre
14	3625205 000		Estrattore Per Ingranaggi	Extractor For Timing Gear	Extracteur Engranges	Zweiback.Abzieher Steuerritzel	Extractor Engranajes
15	3625201 000		Attrezzature Molle Valvole	Valve Spring Lever	Outils Ressorts Valves	Ventilfederheber	Aparejos Muelles Valvulas
16	3625193 000		Attrezzature Montag.Anelli Interni Nj206	Mounting Tool Inner Ring Nj206	Outils Montage Bagues Int. Nj206	Montagew.F.Lagerinnenr. Nj206	Aparejos Montaje Anillo Int. Nj206
17	3625238 000		Chiave Di Controllo	Mixt. Control Screw Factory	Cle De Controle	Gem.Reg.Schraube Factory	Llave De Controle
18	3625173 000		Estrattore Volano	Flywheel Extractor	Extracteur Volant	Schwungradabzieher	Extractor Volante Magnetico
19	3625000 000		Silicone (Tubetto)	Silicon Gasket Three-Bond	Silicon (Tube)	Silikonichtmasse Three-Bond	Silicon
20	3625098 000		Attrezzatura Montag.Catena Distribuzione	Holding Spanner For Sprocket	Outils Montage Chiane De Distribution	Halteschlüssel F. Kettenritzel	Aparejos Montaje Cadena Distribucion

ATTREZZATURE - PARTICOLARI NON FIGURATI
SPECIAL TOOLS - SUPPLEMENTARY PARTS LIST
OUTILS - PARTICULIERS PAS MENTIONNES
SPEZIALWERKZEUGE - NICHT VERZECHNETE TEILE
APAREJOS - PARTICULARES NO FIGURADOS

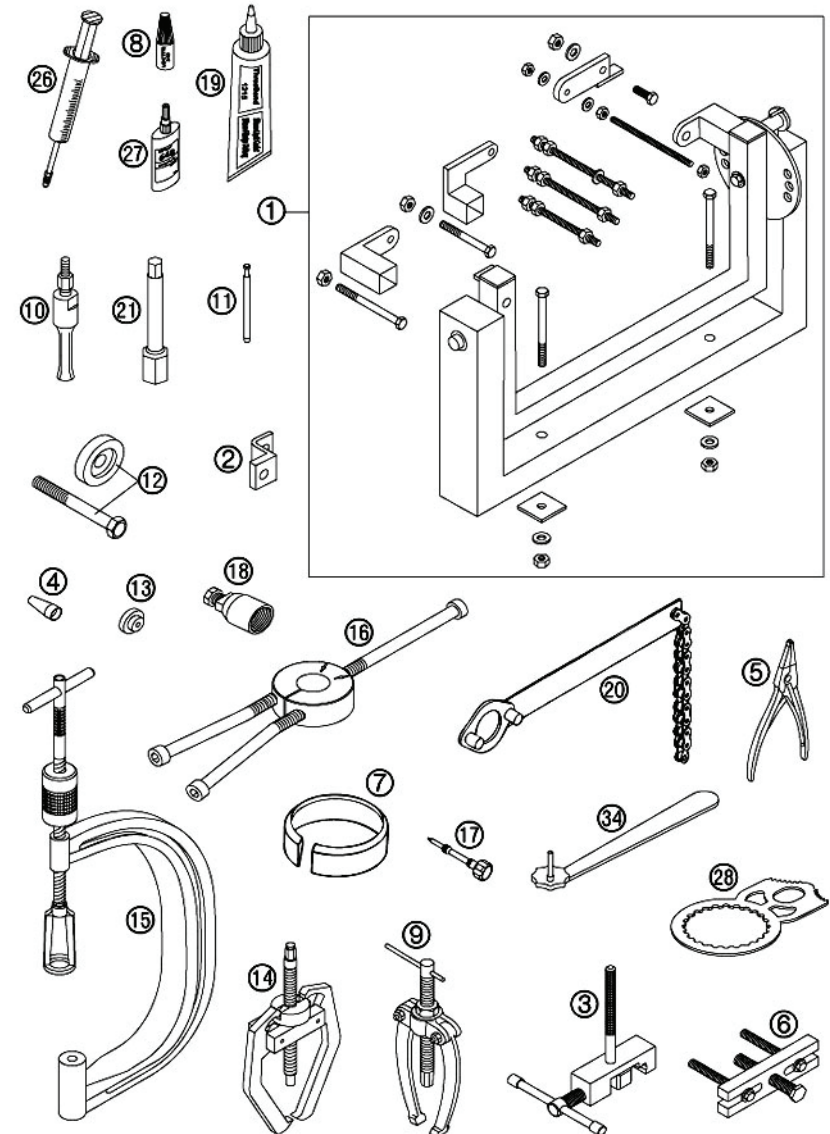

TAV.23

Pos Loc Pos Ps Pos	Numero Number Numéro Número Nummer	Nota Note Note Nota Anm.	Descrizione	Description	Désignation	Beschreibung	Description
21	3625209 000		Chiave Candela 13/16	Spark Plug Wrench 13/16	Cle Bougie 13/16	Zündkerzenschlüssel 13/16	Llave Bujia 13/16
26	3625090 000		Siringa Per Olio Spurgo Frizione	Veni Iniektion Hydr. Clutch Frizione	Seringat Huile Embrayage	Entlüft.Spritze Hydr. Kup- plung	Jeringa Aceite Embrague
27	3625194 000		Loctite 648 Green 24ml	Loctite 648 Verde 6ccm	Loctite 648 Green 24ml	Loctite 648 Grün 24ml	Loctite 648 Green 24ml
28	3625199 000		Estrattore Frizione	Clutch Holder	Extracteur Embrayage	Kupplungshalter Racing	Extractor Embrague
34	3625206 000		Chive Di Controllo	Wrench F.Mixture Control Screw	Cle De Controle	Schlüssel Gemis- chreg.Schraube	Llave De Controle
	1514606 000 1884981 000		Fascetta Carburatore Rr 4t Interruttore Avviamento Rr 4t	Clamp Start Switch	Tige Carburateur Rr4t Interrupteur Starter Rr4t	Schelle F. Bremsschlauch Starterschalter	Brida Carburador Rr4t Interruptor Arranque Rr4t
	2728101 000		Regolatore Motore 250/ 400/450/525 Exc	Rectifier, Engine 250/400/ 450/525 Exc	Regulateur Moteur 250/ 400/450/525 Exc	Regler, 250/400/450/525 Exc	Regolador Motor 250/400/ 450/525 Exc
	2728471 000		Relais Avviam. Mot. 250/ 400/450/525 Exc	Relais, Starting	Relais Demarrage Moteur 250/400/450/525	Starterrelais, 250/400/ 450/525 Exc	Relais Arranque Motor 250/ 400/450/525 Exc
	2911991 000 3625427 000		Termostato Completo Rr4t Kit Trasformazione Exc Da 250cc A 350	Thermostat Box, Rr 4t Modification Kit Exc, From 250cc To 350cc	Thermostat Complet Rr4t Jeu Transformation Exc De 250cc A 350cc	Kompletter Thermostat Schraube, 350cc	Termostato Completo Rr4t Juego Transformacion Exc Desde 250cc A 350cc

ATTREZZATURE - PARTICOLARI NON FIGURATI
SPECIAL TOOLS - SUPPLEMENTARY PARTS LIST
OUTILS - PARTICULIERS PAS MENTIONNES
SPEZIALWERKZEUGE - NICHT VERZECHNETE TEILE
APAREJOS - PARTICULARES NO FIGURADOS

